

# TÜRK LOYDU



## Chapter 3 – Welding JULY 2015

This latest edition incorporates all rule changes. The latest revisions are shown with a vertical line. The section title is framed if the section is revised completely. Changes after the publication of the rule are written in red colour.

Unless otherwise specified, these Rules apply to ships for which the date of contract for construction as defined in IACS PR No.29 is on or after 1<sup>st</sup> of July 2015. New rules or amendments entering into force after the date of contract for construction are to be applied if required by those rules. See Rule Change Notices on TL website for details.

"General Terms and Conditions" of the respective latest edition will be applicable (see Rules for Classification and Surveys).

If there is a difference between the rules in English and in Turkish, the rule in English is to be considered as valid. This publication is available in print and electronic pdf version.

Once downloaded, this document will become UNCONTROLLED. Please check [www.turkloydu.org](http://www.turkloydu.org) for the amended and valid version.

All rights are reserved by Türk Loydu, and content may not be reproduced, disseminated, published, or transferred in any form or by any means, except with the prior written permission of TL.

## **TÜRK LOYDU**

**Head Office** Postane Mah. Tersaneler Cad. No:26 Tuzla 34944 İSTANBUL / TÜRKİYE  
Tel : (90-216) 581 37 00  
Fax : (90-216) 581 38 00  
E-mail : [info@turkloydu.org](mailto:info@turkloydu.org)  
<http://www.turkloydu.org>

### **Regional Offices**

**Ankara** Eskişehir Yolu Mustafa Kemal Mah. 2159. Sokak No : 6/4 Çankaya - ANKARA / TÜRKİYE  
Tel : (90-312) 219 56 34 - 219 68 25  
Fax : (90-312) 219 69 72  
E-mail : [ankara@turkloydu.org](mailto:ankara@turkloydu.org)

**İzmir** Atatürk Cad. No :378 K.4 D.402 Kavalalılar Apt. 35220 Alsancak - İZMİR / TÜRKİYE  
Tel : (90-232) 464 29 88  
Fax : (90-232) 464 87 51  
E-mail : [izmir@turkloydu.org](mailto:izmir@turkloydu.org)

**Adana** Çınarlı Mah. Atatürk Cad. Aziz Naci İş Merkezi No:5 K.1 D.2 Seyhan - ADANA / TÜRKİYE  
Tel : (90- 322) 363 30 12  
Fax : (90- 322) 363 30 19  
E-mail : [adana@turkloydu.org](mailto:adana@turkloydu.org)

**Welding**

<b>Section 1- General Rules</b>	<b>Page</b>
A. General .....	1-2
B. Other Rules, Standards and Specifications .....	1-2
C. Information in Working Documents .....	1-2
D. Materials, Weldability .....	1-3
E. Welding Consumables and Auxiliary Materials .....	1-3
F. Quality Assurance, Responsibility .....	1-4
G. Inspection Tests, Liability .....	1-5
<b>Section 2- Requirements For Welding Shops, Approval</b>	
A. Approval of Welding Shops .....	2-2
B. Requirements for Welding Shops .....	2-3
C. Inspection of Welding Shops .....	2-4
D. Welding Procedure Tests.....	2-5
E. Certification of Approvals, Certificates according to EN 729/ISO 3834.....	2-5
<b>Section 3- Welder's Qualification Tests</b>	
A. General .....	3-2
B. Testing Bodies, Certificates .....	3-2
C. Scope of Testing and Range of Approval .....	3-3
D. Performance of Welder's Qualification Tests .....	3-4
E. Period of Validity, Repeat Tests.....	3-4
F. Other Welder's Tests .....	3-5
<b>Section 4- Welding Procedure Tests, Production Tests</b>	
A. General .....	4-2
B. Performance of Welding Procedure and Production Tests .....	4-3
C. Evaluation of Test Results, Requirements, Repeat Test Specimens, Test Reports.....	4-6
D. Limits of Application, Period of Validity .....	4-7
<b>Section 5- Welding Consumables And Auxiliary Materials</b>	
A. General .....	5-3
B. Covered Electrodes for Manual Metal-Arc Welding of Hull Structural Steels .....	5-14
C. (Flux-cored) Wire-Gas Combinations and Flux-Cored Wire Electrodes for Semi-Mechanized Welding of Hull Structural Steels.....	5-24

## Contents

---

D.	Wire-Flux Combinations for Submerged-Arc Welding of Hull Structural Steels .....	5-29
E.	Welding Consumables and Auxiliary Materials for Electroslag and Electroslag Welding of Hull Structural Steels.....	5-35
F.	Welding Consumables and Auxiliary Materials for High-Strength (Quenched and Tempered) Structural Steels.....	5-37
G.	Welding Consumables and Auxiliary Materials for Steels Tough at Subzero Temperatures .....	5-40
H.	Welding Consumables and Auxiliary Materials for High-Temperature Steels .....	5-42
I.	Austenitic and Austenitic-Ferritic Welding Consumables And Auxiliary Materials For Stainless Steels, Non-Magnetic Steels And Nickel Alloy Steels Tough At Subzero Temperatures.....	5-45
J.	Welding Consumables and Auxiliary Materials for Aluminium Alloys.....	5-50
K.	Welding Consumables and Auxiliary Materials for Copper and Copper Alloys .....	5-54
L.	Welding Consumables and Auxiliary Materials for Nickel and Nickel Alloys .....	5-54

### Section 6- Overweldable Shop Primers

A.	General .....	6-2
B.	Approval Testing of Shop Primers .....	6-2
C.	Certification.....	6-3
D.	Periodical Control Tests.....	6-4

### Section 7- General Design Principles

A.	General .....	7-2
B.	Information Contained in Manufacturing Documents .....	7-2
C.	Materials, Weldability .....	7-3
D.	Design Details.....	7-3
E.	Dimensioning of Welded Joints.....	7-5

### Section 8- Execution of Welds

A.	General .....	8-2
B.	Weld Preparation, Assembly.....	8-3
C.	Weather Protection, Preheating .....	8-3
D.	Welding Positions, Welding Sequence.....	8-4
E.	Performance of Welding.....	8-4
F.	Straightening, Tolerances .....	8-5
G.	Post-Weld-Treatment of Welds .....	8-5

### Section 9- Heat Treatment

A.	Scope.....	9-2
B.	Equipment and Appliances for Heat Treatment.....	9-2
C.	Principles Relating to Heat Treatment.....	9-2
D.	Weather Protection, Preheating, Heat Input during Welding.....	9-3
E.	Post-Weld Heat Treatment.....	9-8

**Section 10- Non-Destructive Testing of Welds**

A.	General .....	10-3
B.	Test Methods, Appliances and Test Media .....	10-3
C.	Inspection Personnel, Supervisors.....	10-4
D.	Inspection Schedule, Inspection Reports .....	10-4
E.	Timing of Inspection, Waiting Times .....	10-5
F.	Preparation and Performance of Tests .....	10-6
G.	Evaluation of Test Results.....	10-6
H.	Extension of the Scope of Inspection .....	10-8
I.	Repairs, Re-inspection .....	10-8
J.	Visual Inspection .....	10-8
K.	Radiographic Inspection.....	10-9
L.	Ultrasonic Inspection.....	10-11
M.	Magnetic Particle Inspection .....	10-16
N.	Liquid Penetrant Inspection .....	10-17

**Section 11- Mechanical and Technological Tests**

A.	Scope.....	11-3
B.	Preparation of Specimens and Testing .....	11-3
C.	Tensile Tests.....	11-3
D.	Bend Tests.....	11-5
E.	Notched Bar Impact Tests.....	11-7
F.	Hardness Testing of Welds .....	11-8
G.	Metallographic Inspections.....	11-9
H.	Inspection reports.....	11-9

**Section 12- Welding of Hull Structures**

A.	General .....	12-3
B.	Approval of Shipyards and Welding Shops, Welding Personnel .....	12-3
C.	Quality Inspection, Responsibility.....	12-4
D.	Materials, Weldability .....	12-5
E.	Welding Consumables and Auxiliary Materials .....	12-5
F.	Welding Procedures, Welding Procedure Tests of Steels for Hull Construction and Marine Structures.....	12-7
G.	Design, Dimensioning .....	12-31
H.	Execution of Welds .....	12-43
I.	Inspection of Welded Joints .....	12-50
J.	Welding Requirements for Cargo Tanks of Gas Tankers.....	12-55

**Section 13- Welding of Steam Boilers**

A.	General .....	13-2
B.	Approval of Welding Shops, Welding Personnel.....	13-2
C.	Quality Inspection, Responsibility.....	13-2
D.	Materials, Weldability .....	13-3
E.	Welding Consumables and Auxiliary Materials .....	13-3

## Contents

---

F.	Welding Procedure Tests .....	13-4
G.	Welding Technique .....	13-7
H.	Post-Weld Heat Treatment.....	13-7
I.	Inspection of Welded Components .....	13-10

### Section 14- Welding of Pressure Vessels

A.	General .....	14-2
B.	Approval of Welding Shops, Welding Personnel.....	14-3
C.	Quality Inspection, Responsibility.....	14-3
D.	Materials, Weldability .....	14-4
E.	Welding Consumables and Auxiliary Materials .....	14-4
F.	Welding Procedure Tests .....	14-5
G.	Welding Technique .....	14-10
H.	Post-Weld Heat Treatment.....	14-11
I.	Inspection of Welded Components .....	14-12

### Section 15- Welding of Pipelines

A.	General .....	15-2
B.	Approval of Welding Shops, Welding Personnel.....	15-2
C.	Quality Inspection, Responsibility.....	15-3
D.	Materials, Weldability .....	15-4
E.	Welding Consumables and Auxiliary Materials .....	15-4
F.	Welding Procedure Tests .....	15-7
G.	Welding Technique .....	15-9
H.	Preheating.....	15-10
I.	Heat Treatment After Forming and Welding.....	15-10
J.	Inspection Of Welded Pipelines .....	15-12

### Section 16- Welding of Machinery Components

A.	General .....	16-2
B.	Approval of Welding Shops, Welding Personnel.....	16-2
C.	Quality Inspection, Responsibility.....	16-3
D.	Materials, Weldability .....	16-4
E.	Welding Consumables and Auxiliary Materials .....	16-4
F.	Welding Procedure Tests .....	16-4
G.	Design, Welding Technique .....	16-10
H.	Post-Weld Heat Treatment.....	16-11
I.	Inspection of Welded Components .....	16-11

**Annex A** Comparison of Equivalent, Internationally Recognized Film System Classes

**Annex B** Welding positions

**SECTION 1****GENERAL RULES**

<b>A. GENERAL</b> .....	<b>1- 2</b>
1. Scope	
2. Application in Other Fields	
3. Exceptions to these Rules	
4. Alterations and Additions	
<b>B. OTHER RULES, STANDARDS AND SPECIFICATIONS</b> .....	<b>1- 2</b>
1. Other Relevant Standards	
2. Differences in Requirements	
<b>C. INFORMATION IN WORKING DOCUMENTS</b> .....	<b>1- 2</b>
1. Drawings, Other Working Documents	
2. Additional Information and Documentation	
<b>D. MATERIALS, WELDABILITY</b> .....	<b>1- 3</b>
1. Choice of Material	
2. Proof of Weldability	
3. Supervision during Fabrication	
<b>E. WELDING CONSUMABLES AND AUXILIARY MATERIALS</b> .....	<b>1- 3</b>
1. Test of Product Suitability, Approval	
2. Supervision during Fabrication	
<b>F. QUALITY ASSURANCE, RESPONSIBILITY</b> .....	<b>1- 4</b>
1. Compliance with Rules, Quality Inspections	
2. Placing Subcontracts	
3. Deviation from Approved Working Documents, Repairs	
4. Marking and Identification of Materials	
5. Marking of Welds	
<b>G. INSPECTION TESTS, LIABILITY</b> .....	<b>1- 5</b>
1. Presentation of Components	
2. Supplying of Test Documentation	
3. Subsequent Defects	

**A. General****1. Scope**

1.1 These Rules apply to all welding work performed in the course of new construction, conversion or repairs carried out on ships and their machinery installations, including steam boilers, pressure vessels and pipelines, for which an application for classification has been submitted to Türk Loydu (TL) or which have been classified by TL.

**Note:**

*The terms "welding", "welding work", "welding process" etc. used in these rules also cover all other thermal and/or mechanized joining processes such as brazing which, because they are deemed as "special processes" under the terms of the quality assurance standards, require pre-qualification which has to be carried out by qualified personnel and constantly monitored.*

1.2 They also apply to all welding work on components, installations or implements for which the Society has issued rules, regulations or other technical directions in which reference is made to these Welding Rules.

1.3 These Welding Rules shall be applied in analogous manner where other rules, regulations or technical directions issued by TL contain no special instructions with regard to welding work.

**2. Application in Other Fields**

These Welding Rules may be applied in analogous manner to welding work carried out on structures and components other than those mentioned under 1., the supervision and inspection of which is the concern of TL. Where necessary, appropriate arrangements shall be made with TL.

**3. Exceptions to these Rules**

Exceptions to these Welding Rules require the consent of TL in each individual case.

**4. Alterations and Additions**

TL reserves the right to alter or add to these Rules

from time to time, should this prove necessary on the basis of more recent knowledge or operating experience.

**B. Other Rules, Standards and Specifications****1. Other Relevant Standards**

1.1 The standards or other technical directions mentioned in the following sections form an integral part of these Welding Rules and shall also be complied with. The same applies to the working documents, e.g. drawings, welding specifications, etc. approved by TL.

1.2 Where the following sections refer to standards in which a date is specified, the current version shall apply.

1.3 Where the following sections and chapters refer to both EN and ISO standards, and if, where they are both specified, the standards are not identical, the EN standards shall take precedence. Where the two standards are identical, either the EN or the ISO standard may be used.

1.4 The application of other rules, standards, regulations or other technical directions is subject to the consent of TL in each individual case. TL may make any such approval conditional upon construction and dimensioning also being subject to these directions.

**2. Differences in Requirements**

If there are differences in requirements between these Rules and other relevant standards or specifications, the requirements of these Welding Rules shall take precedence, unless otherwise stipulated.

**C. Information in Working Documents****1. Drawings, Other Working Documents**

1.1 The drawings and other working documents to be submitted before commencing the fabrication



work must contain all the necessary details for the preparation, execution and, where applicable, the inspection of the welds.

This information shall in particular include details of:

- Base materials, shapes and dimensions of products,
- Welding processes, welding consumables and auxiliary materials,
- Shapes and dimensions of welds,
- Preheating and heat input during welding,
- Heat treatment after welding,
- Subsequent treatment of the welds,
- Nature and scope of inspections,
- Requirements applicable to the welded joints (e.g. quality grade, weld performance, evaluation category or the like).

**1.2** Provided that in the fabrication of ship's structures, the materials, welding processes, welding consumables, auxiliary materials and the shapes and dimensions of welds conform to normal shipbuilding practice, these Rules and the approvals, these details need not be specified.

## **2. Additional Information and Documentation**

For particular structures (e.g. liquefied gas tanks), materials (e.g. quenched and tempered structural steels and clad plates) or welding processes, the following additional information and documentation shall be provided as necessary:

- Weld preparation, assembly, auxiliary (tack) welds,
- Welding positions, welding sequence (drawings)
- Weld build-up, number of passes,
- Heat input during welding (heat input per unit

length of weld).

This information shall be combined in a welding specification. For test schedules and specifications for non-destructive testing, please refer to Section 10.

## **D. Materials, Weldability**

### **1. Choice of Material**

All materials shall be of proven weldability. They shall be chosen in accordance with the intended application and the conditions of service and shall comply with the requirements stated in Material Rules. Their properties shall be documented to the specified extent by test certificates, e.g. in conformity with EN 10204.

#### *Note:*

*The hull structural steels and rolled products described in Material Rules, for the manufacture of steam boilers, pressure vessel, pipelines and machinery are deemed to be of proven weldability.*

### **2. Proof of Weldability**

If, notwithstanding item. 1., materials are to be welded whose properties are not described in **TL** Material Rules, the welding shop concerned shall furnish proof of their weldability (e.g. by reference to existing standards) or submit special material specifications for approval. If there is doubt as to the weldability of a material, the welding shop shall specially demonstrate this in the course of the welding procedure tests.

### **3. Supervision during Fabrication**

The welding shop shall ensure that only materials which meet the requirements of 1. and 2. are used for both original and replacement supplies, and shall furnish proof thereof to the Surveyor on request.

## **E. Welding Consumables and Auxiliary Materials**

### **1. Test of Product Suitability, Approval**

**1.1** The welding consumables and auxiliary materials shall enable a welded joint to be made which

is suited to the base material and the operating conditions. They shall have been tested for product suitability in accordance with Section 5 and approved for the application in question. This provision applies in an analogous manner to brazing metals.

**1.2** Approval shall as a rule have been given by **TL**. If, in special cases, e.g. repairs, no welding consumables which have been tested by **TL** are available, welding consumables approved by other recognized testing bodies may be used with **TL**'s consent. Relevant proof of this must be submitted to **TL**'s surveyor.

## **2. Supervision during Fabrication**

The welding shop's supervisors shall ensure that only tested welding consumables and auxiliary materials which have been approved by **TL** are used and shall furnish proof thereof to the Surveyor on request

## **F. Quality Assurance, Responsibility**

### **1. Compliance with Rules, Quality Inspections**

**1.1** Shipyards or welding shops are responsible for ensuring that the welding work conforms to these and any supplementary rules as applicable, the approved working documents, any conditions as may be stated in the approvals, good shipbuilding practice, and also the state of the art technology relating to welding

**1.2** Shipyards or welding shops must ensure, by means of regular in-house quality inspections during the production process and at the end of the welding work, that such work has been properly and expertly executed. The responsibilities of the welding supervisors are also covered in ISO 14731. The tests to be performed by **TL** surveyors shall not relieve the welding shop of this responsibility.

**1.3** The range and extent of the quality inspections required is determined by the structure in question. In each case, however, it is necessary to ensure that the specified materials, welding consumables and auxiliary materials are used and that weld preparation, assembly, performance of tack and welding work, together with the

accuracy to size and completeness of the components and welded joints meet the requirements.

**1.4** Following inspection by the welding shop and any repairs which may be necessary, the components must be presented to **TL**'s Surveyor for inspection at appropriate stages of construction, easily accessible and as a rule unpainted. The Surveyor may reject those components which have been inadequately inspected by the welding shop and specify that a component be presented again after a successful inspection by the welding shop and, where necessary repairs.

## **2. Placing Subcontracts**

**2.1** When placing orders with subcontractors, independent branch companies or suppliers as well as outside companies working in the welding shop who are themselves approved (so-called "contract companies", see note Section 2, A.1.1) the "prime contractor" must ensure that the provisions stated in 1. are also complied with by the "subcontractors".

**2.2** Where the outside companies working in the welding shop are not themselves approved or where contract labour is used, the welding shop placing the contract shall be responsible for ensuring that the conditions stated in 1. are complied with and that the quality inspections are performed. **TL** shall be notified of the placing of subcontracts or the use of contract labor.

## **3. Deviation from Approved Working Documents, Repairs**

**3.1** If alterations to the design compared with the approved drawings or deviations from approved fabrication procedures become necessary, the welding shop shall promptly obtain **TL**'s consent thereto. **TL**'s Surveyor shall be notified of any repairs which become necessary during fabrication.

**3.2** If, due to inadequate or incorrect information in the production documents (e.g. workshop drawings), the quality or functional capability of a component cannot be guaranteed or is doubtful, **TL** may require appropriate repairs to be carried out.

**3.3** This shall apply in an analogous manner to supplementary or additional components (e.g. reinforcements) even if these are not specified during the examination of the drawing or could not be specified owing to a lack of detail shown in the "class plans" (see Chapter 1 - Hull, Section 1, G.).

#### **4. Marking and Identification of Materials**

**4.1** The materials shall be marked in such a way that they can be identified and matched up with the test certificates even during and after fabrication.

**4.2** If the marking is likely to be erased during manufacture, the welding shop shall promptly see to it that it is transferred to another part of the product. This can be dispensed with in the case of small parts of minor importance such as ribs or bracings, provided that any confusion of materials can be prevented by operational means.

#### **5. Marking of Welds**

**5.1** In the fabrication of steam boilers and vessels under internal pressure, each weld section shall be marked with the symbol of the welder who executed it. This may be dispensed with if the welding shop supervisory staff keeps a record of the names of the welders who execute the individual weld sections.

**5.2** In special cases, TL may also require marking or record-keeping as described in 5.1 for other components or their welded joints.

### **G. Inspection Tests, Liability**

#### **1. Presentation of Components**

The welding shop shall be obliged to present the components to the Surveyor for the required intermediate and final inspections. Steps shall be taken

to ensure unimpeded access to the welds. The welds shall not be treated with coatings or preservatives which make it difficult or impossible to assess the condition of the welds.

#### **2. Supplying of Test Documentation**

For the inspections, all the manufacturer's records and documents concerning the quality assurance measures undertaken by him shall be submitted. These include in particular:

- Drawings (approved if required) and other working documents,
- Material test certificates,
- Welder's and welding procedure test certificates,
- Test reports and films of the non-destructive tests,
- Certificates of hot-forming and heat treatment, where applicable,
- Results of production tests, intermediate results if necessary.

#### **3. Subsequent Defects**

**3.1** TL gives no guarantee that the products, welded structures or components tested by its Surveyor to the extent laid down (normally random tests) conform to the requirements in every respect and that their manufacture has been performed correctly and in accordance with the tested procedures.

**3.2** Products or welded structures which prove defective in subsequent use or in the operation or processes which exhibit deficiencies in use may be rejected even if an earlier inspection was satisfactory, if it is not possible to remedy the defect or deficiency.

**SECTION 2****REQUIREMENTS FOR WELDING SHOPS, APPROVAL**

<b>A.</b>	<b>APPROVAL OF WELDING SHOPS .....</b>	<b>2- 2</b>
	1. General	
	2. Application for Approval	
	3. Approval Documents	
	4. Period of Validity of Approval, Renewal	
	5. Changes, Revocation	
<b>B.</b>	<b>REQUIREMENTS FOR WELDING SHOPS.....</b>	<b>2- 3</b>
	1. Technical Equipment	
	2. Welding Shop Supervisory Staff	
	3. Welders and Operators	
	4. Test Supervisory Staff and Test Personnel	
<b>C.</b>	<b>INSPECTION OF WELDING SHOPS .....</b>	<b>2- 4</b>
	1. Shop Inspection	
	2. Submission of Documentation	
<b>D.</b>	<b>WELDING PROCEDURE TESTS .....</b>	<b>2- 5</b>
	1. General Provisions	
	2. Scope of the Welding Procedure Test	
	3. Recognition of Other Tests	
<b>E.</b>	<b>CERTIFICATION OF APPROVALS, CERTIFICATES ACCORDING TO EN 729/ISO 3834.....</b>	<b>2- 5</b>

## A. Approval of Welding Shops

### 1. General

1.1 Shipyards and welding shops, including branches and subcontractors, wishing to perform welding work covered by these Rules must have been approved for this work by TL. (See Section 12, 13, 14, 15, 16). The preconditions for this approval are that the shops satisfy the requirements under B., have been inspected by TL in accordance with C. and, where necessary, have carried out welding procedure tests in accordance with D.

**Note:**

*The term "welding shop" used in the following paragraphs is understood to mean the welding production plant which, due to its space and organizational facilities, can be regarded as an independent unit. Branches and subcontractors shall generally be regarded as "independent" facilities which have to meet the requirements stated below. In particular, each welding shop must have available its own permanent in-house welding supervisory staff. Outside companies working in welding shops may be approved as independent companies. For details of this and contract labour, see Section 1, F.2.*

1.2 Any approval in accordance with 1.1 covers the most essential welding quality requirements in accordance with the standards ISO 3834. For certification under the terms of these standards, the requirements set out in 2.2 and 3.2 must also be met. These additional requirements shall be regarded as having been met when the welding shop has in place a certified quality assurance system in accordance with the series of standards ISO 9000.

1.3 In individual valid exceptions, e.g. in the case of repairs, TL may grant approval for welding work to be executed even without approval being granted to the welding shop, subject to a time limit and restricted to a specific structure, if the welding shop pre-conditions have been specified for such work and the quality of the welds performed is demonstrated by relevant tests, e.g. non-destructive and/or production tests.

## 2. Application for Approval

**Introductory remark:**

*Where no special provisions are given in the following paragraphs or, in an individual case, no other arrangements are made, the provisions for "Approval" set out in accordance with these rules shall also apply in an analogous manner to "Certification" in accordance with ISO 3834.*

2.1 Approval shall be applied for in writing to the TL's head office. The application shall contain the following details, which shall be related to each other as far as possible, of the scope of the desired approval:

- Nature of the structure and/or components,
- Materials and dimensional ranges,
- Welding procedures and positions,
- Heat treatments (if necessary)
- Weld factor (for steam boilers and pressure vessels).

2.2 If a certificate of compliance with the welding quality requirements stipulated in ISO 3834-2, -3 or -4 is required over and above approval in accordance with these Rules for Welding, this must be expressly noted in the application for approval.

## 3. Approval Documents

3.1 Welding shops applying for approval to carry out welding work must submit the following documents to the TL's head office with their application for approval:

- A description of the welding shop
- Copies of the qualification documents of the welding supervisor(s)
- Copies of the valid welder's certificates or a list of the qualified welders (testing standard,

testing body, date of testing, test category, date of last retest) signed by the Surveyor.

- Copies of documentation as proof of the qualification of supervisory and test personnel, as appropriate.
- Copies of reports of welding procedure tests performed elsewhere, including the approvals granted, as appropriate

**3.2** For certification in accordance with 2.2, information and documents relating to the elements specified in Annex 1 to ISO 3834-1 for the respective grade of requirement (ISO 3834-2 = full, -3 = standard, or -4 = basic quality requirements) must also be enclosed with the application for approval (e.g. in the form of relevant procedure instructions):

- Contract review,
- Design review,
- Treatment of subcontractors ,
- Equipment maintenance,
- Quality inspections,
- Nonconformance,
- Calibration,
- Identification,
- Traceability.

If the welding shop operates a certified quality assurance system conforming to the series of standards ISO 9000, the QA manual and - if specified in Annex 1 to ISO 3834-1 - documentation relating to the quality assurance measures performed (quality reports) must be submitted to **TL** for inspection in place of the above information and documents.

#### **4. Period of Validity of Approval, Renewal**

**4.1** An approval granted according to these Rules

or certification in accordance with ISO 3834 shall be valid for three years. Provided that welding work is constantly performed under **TL**'s supervision during the validity of the approval and that the preconditions on which approval was granted have not changed, approval may be extended on application by the welding shop for further three years subject to an appropriate inspection.

**4.2** If no welding work has been carried out under **TL**'s supervision for more than a year, an application for renewal of the approval, enclosing updated information as specified in 3., must be made no later than the end of the 3-year period of validity. Approval may only be renewed if the necessary preconditions continue to apply, which shall be verified by a re-inspection of the welding shop. The approval may then be renewed for a further period of three years.

### **5. Changes, Revocation**

**5.1** If the preconditions under which approval was granted change, e.g. through the use of untested welding procedures, materials and/or welding consumables, or if changes are made to the welding shop supervisory staff, **TL** shall be notified voluntarily. As a rule, this necessitates a revision of the approval.

**5.2** An approval shall cease to be valid if the preconditions under which it was granted cease to apply. If serious defects are detected in the components or the welds, **TL** is entitled to carry out interim re-inspections of the production facilities and may, if necessary, revoke the approval.

### **B. Requirements for Welding Shops**

#### **1. Technical Equipment**

**1.1** Welding shops must have at their disposal suitable workshops, equipment, machinery and jigs on a scale necessary for proper performance of the welding work. This includes, for example, the provision of storage facilities and baking equipment for the welding consumables and auxiliary materials, preheating and heat treatment equipment, testing appliances and equipment, and means of weather protection for carrying out welding work in the open air.

**1.2** Equipment and facilities not belonging to the welding shop itself, e.g. testing appliances, may be taken into account when evaluating the capabilities of a welding shop, provided that the preconditions necessary to proper fabrication and testing are satisfied and that such equipment is available without restriction.

## **2. Welding Shop Supervisory Staff**

**2.1** Welding shops or branches (see note to A.1.) shall have at least one fully qualified welding supervisor, who is responsible for ensuring that the welding work is competently performed. Welding supervisors shall have training and experience corresponding to the scope of the fabrication work and shall provide **TL** with the necessary documentary proof thereof.

**2.2** The names of the welding supervisor in charge and his deputy must be notified to **TL**. If the supervision role is carried out by more than one person, the responsibilities and tasks of each person must be established and specified. The welding supervisor in charge and his deputy shall be recognized by **TL** as part of the approval for the welding shop.

**2.3** The following persons shall be appointed as welding supervisors depending on the nature and scope of the work:

- Welding engineers for fabrication of important components of the hull structure and of off-shore installations, also of handling equipment, steam boilers, pressure vessels, pressure lines and engine and transmission components,
- Welding specialists for fabrication of simpler or less heavily stressed components.

For information relating to the qualification of the welding supervisory staff, their tasks and responsibilities, see ISO 14731.

**2.4** The welding supervisor(s) shall be permanently employed by the welding shop. Supervision of the welding work by outside staff is not acceptable.

## **3. Welders and Operators**

**3.1** Welding shops shall be staffed with qualified

welders and, for fully mechanized and automatic welding equipment, adequately trained operators. The required number of qualified welders is determined by the size of the welding shop and the scope of the welding work to be performed under **TL** supervision. However, a minimum of two qualified welders are required for each welding process.

**3.2** Welders for manual and semi-mechanized welding must have passed a test in accordance with Section 3 and in conformity with a recognized standard (e.g. EN ISO 9606-2, EN 287/ISO 9606, ASME Section IX or TSE as applicable). The test shall cover the conditions likely to occur in the fabrication work with regard to the process(es), base material, welding consumable and welding position(s). The production of test pieces in a successfully completed welding procedure or production test may be taken as proof of manual skill for testing of welders.

**3.3** Operators of fully mechanized or automatic welding equipment and of welding robots must have been trained in the use of the equipment. They must also be capable of setting or programming and operating the equipment in such a way that the required weld quality is achieved. The qualification of such personnel must be demonstrated in accordance with EN 1418/ISO 14732 on welded test pieces, e.g. in welding procedure or fabrication tests or by means of random tests and operational tests as applicable (please refer to the standards).

## **4. Test Supervisory Staff and Test Personnel**

Where the welding shop has its own test supervisory staff and test personnel (see Section 10, C.), documentary proof of their qualification (e.g. certificates conforming to ISO 9712) shall be submitted to **TL**.

## **C. Inspection of Welding Shops**

### **1. Shop Inspection**

Before starting fabrication work, it shall be proved to **TL**'s Surveyor in the course of an inspection of the welding shop that the requirements applicable to the technical equipment as stated in B.1. are satisfied. For this purpose the Surveyor shall be given access to all

departments and laboratories relevant to fabrication and testing. The fabrication and quality control procedures shall also be described and explained to him if he so requests. For certification according to ISO 3834, compliance with the additional quality requirements stated in the standards shall be demonstrated to the Surveyor (see A.3.2).

## 2. Submission of Documentation

As part of the welding shop inspection procedure, originals of all documents necessary in order to evaluate the fabrication and quality assurance procedures shall be submitted to the Surveyor. These especially include the welding supervisor's qualification documents, welder's certificates, reports on previous welding procedure tests, and results of quality tests and welder's retests. For certification according to ISO 3834, compliance with the additional quality requirements stated in the standards shall be demonstrated to the Surveyor (see A.3.2).

## D. Welding Procedure Tests

### 1. General Provisions

1.1 If welding procedure tests are required, their successful performance shall be a further precondition for the approval of a welding shop or for extending its approval. Requirements for the performance of these tests and requirements applicable to test results are given in Section 4, 12 and 16.

1.2 Welding procedure tests shall be performed in such a way that the conditions of fabrication can be covered with regard to materials, welding processes, welding positions, welding consumables and auxiliary materials, wall thicknesses, shapes of welds and heat treatments. The properties of the base materials for the test pieces shall be documented by test certificates.

### 2. Scope of the Welding Procedure Test

#### *Note:*

*Please refer to the detailed information given in Section 4, D.*

2.1 In general, a welding procedure test is valid only within the limits specified in the approval and is not

transferable from the welding shop where it is performed to a different welding shop. **TL** may permit exceptions in the case of a nearby branch welding shop which is under the constant supervision of the main welding shop, where the same fabrication conditions prevail and where the same welding processes are used.

2.2 Welding procedure tests performed in a workshop are in general not simultaneously valid for welding in the field. In such cases, the welding procedure test must be repeated in whole or in part under field conditions as determined by **TL**. **TL** may waive the repeat testing by prior agreement if the properties of the field welds are documented by production tests.

### 3. Recognition of Other Tests

Welding procedure tests performed under the supervision of other testing bodies which are independent of the works may be recognized in full or in part by **TL** at the welding shop's request if this is acceptable on the basis of the test results. In such a case, the complete test reports and the approval certificate of the other testing body shall be submitted to **TL** for evaluation.

## E. Certification of Approvals, Certificates According to ISO 3834

1. **TL** issues certificates for the approval of welding shops to carry out welding work and for welding procedure tests if the requirements set out in these rules are satisfied in the tests. These welding shop and welding procedure approvals are valid within the limits stated in the certificates.

2. Where proof has been furnished that the additional requirements listed in A.3.2 according to ISO 3834 have been met, **TL** issues a certificate based on this in accordance with this standard.

3. If previously issued approval certificates are replaced or supplemented by more recent ones (see A.5.1) and the details in the more recent approval certificates contradict those of previous approvals, the details in the more recent certificate shall be valid. This applies especially to the range of application, e.g. for a specific welding process.



## SECTION 3

### WELDER’S QUALIFICATION TESTS

<b>A.</b>	<b>GENERAL .....</b>	<b>3- 2</b>
	1. Required Testing (Welding Processes)	
	2. Training, Manual Skill, Knowledge	
	3. Lists of Welders, Symbols	
<b>B.</b>	<b>TESTING BODIES, CERTIFICATES .....</b>	<b>3- 2</b>
	1. Initial Tests in the Welding Shop	
	2. Repeat Tests in the Welding Shop	
	3. Tests Conducted by Other Testing Bodies	
	4. Tests Conducted as Part of the Welding Procedure Tests	
<b>C.</b>	<b>SCOPE OF TESTING AND RANGE OF APPROVAL .....</b>	<b>3- 3</b>
	1. Base Materials	
	2. Joint Types	
	3. Other Inclusions and Exclusions	
	4. Deviations, Special Features, Particular Applications	
<b>D.</b>	<b>PERFORMANCE OF WELDER’S QUALIFICATION TESTS .....</b>	<b>3- 4</b>
	1. Welding of Test Pieces, Welding Procedure Specification (WPS)	
	2. Test Pieces, Specimen Types and Tests	
	3. Evaluation of Test Pieces and Specimens, Recording of Results	
<b>E.</b>	<b>PERIOD OF VALIDITY, REPEAT TESTS.....</b>	<b>3- 4</b>
	1. Standard Period of Validity	
	2. Reduced Period of Validity	
	3. Continuous Supervision	
	4. Extensions to the Period of Validity, Repeat Tests	
<b>F.</b>	<b>OTHER WELDER’S TESTS.....</b>	<b>3- 5</b>
	1. Other Rules and Standards	
	2. Exceptions	

**Preliminary remarks:**

*The following rules for the testing of welders conform to or make use of the standards ISO 9606, Parts 1 (Steel) and 2 (Aluminium). For other non-ferrous metals, EN ISO 9606-2 shall continue to apply until the corresponding parts of ISO 9606 come into force.*

*Where no details of the tests are specified in the following Rules, the tests shall be performed in accordance with these standards. References in the text also refer to these standards unless otherwise specified.*

*Some deviations from the standards have been made with regard to the testing of steel welders (ISO 9606-1), especially in relation to the ranges of approval for base materials and weld types which have been somewhat narrowed down compared with the standards. As far as the testing of non-ferrous metal welders is concerned, it is chiefly the weld forms which differ from those of the standard.*

**A. General****1. Required Testing (Welding Processes)**

**1.1** Welder's qualification tests are required for all welders who are to perform welding work using manually guided welding appliances (as for manual metal arc welding or semi-mechanized gas-shielded metal arc and/or welding using flux-cored electrodes) and where the quality of the welded joints depends mainly on the manual skill of the welder.

**1.2** For welders who are required to perform welding work on steam boiler installations, the Technical Rules for Steam Boilers, TRD 201, Annex 2, Guidelines for testing and supervising boiler welders, shall also be complied with. The inclusions and exclusions specified in these Regulations shall apply hereto.

**1.3** The qualification of operators of fully mechanized and automatic welding equipment and of welding robot, shall be demonstrated in accordance with EN 1418/ISO 14732 on welded test pieces e.g. as part of the welding procedure or fabrication tests or by means of random tests and operational tests (see the standards).

**2. Training, Manual Skill, Knowledge**

**2.1** Welder's qualification tests may only be taken by welders who have received appropriate previous training (both practical and theoretical) and who have had sufficient opportunity to practise the craft.

**2.2** Besides the necessary manual skill, the welder shall also possess the professional knowledge enabling him to perform the welding work competently and safely. See the relevant information in the standards.

**3. Lists of Welders, Symbols**

**3.1** Welding shops are required to maintain lists or files which furnish information about the number, names (code number) and test scope of the welders and the dates of their initial and repeat tests. These lists shall be submitted to TL for examination on demand together with the relevant original documentation or, where appropriate, together with the description of the welding shop. (See Section 2, A.3).

**3.2** Each welder shall be assigned an unmistakable symbol, which shall be recorded in the testing documentation (certificates, lists, etc.). TL may in addition - depending on the application - require the components and welds to be marked with the symbol of the welder who performed the work. (See Section 1, F.5).

**B. Testing Bodies, Certificates****1. Initial Tests in the Welding Shop**

The initial testing of welders in the welding shop is to be conducted by the welding supervisory staff in the presence of TL's representative. Following submission of the assessment forms completed by the welding shop and initialled by the Surveyor, these tests will be confirmed by TL Head Office in the form of test certificates.

**2. Repeat Tests in the Welding Shop**

**2.1** Repeat tests taken by welders who have been certified by TL or by those certified by other recognized testing bodies and recognized by TL may be conducted

independently by the welding engineer recognized by **TL** in conjunction with the approval granted to the welding shop. Tests conducted by other welding supervisors shall be carried out in the presence of **TL**'s representative.

**2.2** The extension of the validity of a test certified by **TL** by a further two years may, however, only be authorized by **TL**. For this purpose, a full set of test documentation (welding procedure specification, assessment form and test certificate) must be submitted to the Surveyor. See E.4.

### **3. Tests Conducted by Other Testing Bodies**

Welder's qualification tests conducted by other testing bodies (e.g. welding training and testing establishments or welding training establishments, see the foreword to DIN EN 287 and EN ISO 9606) which are independent of the welding shop and which are recognized by **TL** will be recognized by **TL** subject to the test categories specified below. Such recognition is subject to the submission to **TL** of a full set of test documentation, as described in 2.2 above.

### **4. Tests Conducted as Part of the Welding Procedure Tests**

The testing of welders may be included in the welding procedure tests see Section 4, B.5.3 and their names will then be included in the welding procedure approval. A welder's qualification test certificate conforming to the standards may, however, only be issued provided that all the provisions of the standards, e.g. scope of test and job knowledge testing, have been met and that this is recorded in an assessment form which has been completed accordingly.

## **C. Scope of Testing and Range of Approval**

### **1. Base Materials**

**1.1** In the case of base materials - and in contrast to the provisions of the standard ISO 9606-1 - higher-strength (hull structural) steels with a minimum yield strength  $R_{eH}$  of up to 355 [N/mm<sup>2</sup>] (up to 360 [N/mm<sup>2</sup>] in the case of pipe-grade steels) shall only be considered, following testing, as being included in the

material category W 01 if the test (using the appropriate welding consumables) was also performed on a higher-strength steel.

**1.2** Unless otherwise stipulated by **TL** in a particular case, the test categories conforming to the standards shall also apply to the base materials. **TL** may, however, require a more precise subdivision of the categories in accordance with the note to Section 12, F.2.

### **2. Joint Types**

**2.1** In the case of joint types - and in contrast to the provisions of the standards - the test performed on butt welds does not also include fillet welds. Where welders are required to lay down butt welds as well as fillet welds, both weld forms must be included in the test.

**2.2** Unless otherwise stipulated by **TL** in a particular case, the test categories conforming to the standards shall also apply to the weld forms.

### **3. Other Inclusions and Exclusions**

Unless otherwise specified by **TL** in a particular case, the inclusions and exclusions stipulated in the standards shall otherwise apply.

### **4. Deviations, Special Features, Particular Applications**

**4.1** If deviations from the standards or these rules for testing are to be included in the welder's qualification test, this shall be agreed with **TL** beforehand. The kind of the deviation or special feature is to be indicated on the assessment form under "Remarks" and will be noted in the test certificate.

**4.2** Welder's qualification tests for particular applications (particular materials, shapes of weld, welding processes) which are not covered by the tests and work assignments described above and in the standards (e.g. for clad plates or offshore pipe junctions) shall be carried out according to a test schedule to be agreed with **TL** on a case-by-case basis.

## D. Performance of Welder's Qualification Tests

### 1. Welding of Test Pieces, Welding Procedure Specification (WPS)

For welding test pieces, a "Manufacturer's" Welding Procedure Specification (WPS) shall be produced by the welding shop - a separate one for each welding task - in accordance with the standards EN 287 resp. ISO 9606. The welding conditions for testing shall match those during fabrication.

### 2. Test Pieces, Specimen Types and Tests

The test pieces, the specimen types and the performance of the tests shall conform to the standards.

### 3. Evaluation of Test Pieces and Specimens, Recording of Results

3.1 Depending upon the kind and scope of the tests, test pieces and specimens shall be evaluated, conforming to the specifications of the standards, according to the following criteria:

- Thickness, reinforcement and appearance of weld (external results),
- Radiograph (internal results),
- Appearance of fracture (internal results),
- Mechanical properties, where applicable,
- Metallographic specimen, if required.

3.2 A welder shall be regarded as having passed the test provided that the imperfections fall within the limits of assessment category B conforming to ISO 5817. Exceptions to this rule include the following imperfections: weld reinforcement too large (butt and fillet welds), excessive fillet weld thickness and excessive root reinforcement, to which assessment category C applies.

3.3 A test shall only be passed as successful if all the requirements stated in the standards relating to the

test piece in question and the specimens taken from it can be evaluated as having been met. Repeat test pieces and specimens are subject to the specifications of the standards EN 287 resp. ISO 9606.

3.4 Details and results of the tests are to be recorded.

## E. Period of Validity, Repeat Tests

### 1. Standard Period of Validity

A welder's qualification test remains valid for two years with effect from the test date, provided that during this period welding work is constantly performed in the range of approval of the test and the work of the welder is monitored by the welding supervisors at all times. This is to be confirmed by the welding supervisors on the welder's qualification test certificate at intervals of no more than six months. The provisions given in the standards in this regard shall also apply.

### 2. Reduced Period of Validity

2.1 TL may reduce the validity of the test (e.g. to one year) if the supervision of the welder's work mainly takes the form of visual inspections.

2.2 A repeat test relating to an individual welding process is required where a welder who has been tested in more than one welding process has not used the process in question for longer than six months.

2.3 A repeat test is in any case necessary where a welder has not performed any welding work as defined in item 1 for longer than six months.

2.4 TL may demand a repeat test at any time should reasonable doubts arise as to a welder's skill.

### 3. Continuous Supervision

3.1 A repeat test may be dispensed with where the quality of the work performed by the welder in the work assignment range corresponding to his test category is

systematically and verifiably monitored during fabrication by the welding shop's welding engineer recognized by **TL** and this is confirmed, as described above in paragraph 1 above, at intervals of no more than six months.

**3.2** For this purpose the following measures shall be implemented at times of which the welder has no prior knowledge and which shall occur at intervals of not more than three months:

- Destructive tests on test welds or sections of weld produced by the welder (wherever possible, in the most difficult positions), and/or
- Non-destructive tests for defects on production welds provided that these tests can be documented (e.g. by means of radiographs).

**3.3** The results of these tests are to be noted in the lists of welding personnel and are to be submitted to **TL** for examination and confirmation at intervals of not more than one year.

#### **4. Extensions to the Period of Validity, Repeat Tests**

**4.1** The validity of a welder's qualification test certified by **TL** may be extended by a further two years at a time only if specified by **TL** on the test certificate provided that the preconditions relating to this as stated above resp. in the standards have been met and provided that this was confirmed by the employer (welding supervisor) on the test certificate for the six month period as applicable.

**4.2** An extension may only be certified for the range of approval in which the initial test took place.

**4.3** If the conditions under which an extension is granted, as specified above, are not met a repeat test is to be carried out conforming in scope to the initial test. If

a repeat test is carried out with a restricted scope of testing compared with the initial test, the subsequent range of approval is determined by scope of testing of the repeat test.

#### **F. Other Welder's Tests**

##### **1. Other Rules and Standards**

**1.1** **TL** may consent to the performance of welder's qualification tests in accordance with other comparable recognized rules, standards or codes. The work assignments of welders tested in accordance with these tests will be specified in analogous manner to the above Rules, depending on the scope of testing. The period of validity is as specified in E.

**1.2** Welder's tests conforming to other rules, standards or codes which have been conducted by an independent testing body in analogous manner to B.3. may be recognized by **TL** subject to the foregoing provisions. The relevant welding procedure specifications, test reports, test certificates and, upon request, the relevant rules, standards or codes shall be submitted to **TL** for this purpose.

##### **2. Exceptions**

In justified exceptional circumstances (e.g. repairs), the Surveyor may, subject to a specified time limit and to limitation to a particular structure, authorize the employment of well-trained and experienced welders without the documentary qualifications stipulated above, provided that he has reason to believe that the welders concerned are competent to perform the work envisaged and that the quality of the welds produced by them can be verified by suitable, e.g. nondestructive tests.

**SECTION 4****WELDING PROCEDURE TESTS, PRODUCTION TESTS**

<b>A. GENERAL .....</b>	<b>4- 2</b>
1. Welding Procedure Tests in the User's Works	
2. Preliminary Welding Procedure Test	
3. Production Tests	
<b>B. PERFORMANCE OF WELDING PROCEDURE AND PRODUCTION TESTS.....</b>	<b>4- 3</b>
1. Application for Approval	
2. Scope of Testing, Requirements, Test Schedule	
3. Materials, Welding Consumables and Auxiliary Materials	
4. Test Pieces, Dimensions, Direction of Rolling, Weld Form, Welding Positions	
5. Welding of Test Pieces	
6. Post-weld Heat Treatment, Other Kinds of After-Treatment	
7. Non-Destructive Testing	
8. Sectioning of Test Pieces, Preparation of Specimens	
9. Shapes and Dimensions of Test Specimens, Mechanical and Technological Tests	
<b>C. EVALUATION OF TEST RESULTS, REQUIREMENTS, REPEAT TEST SPECIMENS, TEST REPORTS.....</b>	<b>4- 6</b>
1. Designation of Test Results	
2. Requirements, Repeat Test Specimens	
3. Reports, Storage Times	
<b>D. LIMITS OF APPLICATION, PERIOD OF VALIDITY.....</b>	<b>4- 7</b>
1. Works and Sub-Works	
2. Range of Application	
3. Period of Validity	

## A. General

### 1. Welding Procedure Tests in the User's Works

**1.1** Welding procedure tests shall be carried out under **TL**'s supervision in the user's works before starting the fabrication work according to the scope described in Section 12 to 16 for the different areas of application under workshop conditions. Workplace conditions (weather protection, welding equipment, operating jigs, welders, production allowances etc.) and any intended extreme cold-forming operations as well as heat treatments of the materials and/or the welds where applicable shall form an integral part of the welding procedure tests.

**1.2** **TL** may dispense with a welding procedure test for certain standard processes on materials which are easy to weld where the quality of the welded joints essentially depends on the choice of the welding consumables and the manual skill of the welder, e.g. manual metal arc welding (SMAW) or semi-mechanised gas-shielded metal arc welding (GMAW), of normal-strength hull structural steels, comparable construction steels, forgings or steel castings, except for vertical-down (PG) welding.

Table 4.1 gives a summary of the documentary proof required for recognition of welding processes in the different areas of application. The provisions in the individual Sections do, however, take precedence.

**1.3** Welding procedure tests which have already been carried out under the supervision of other independent testing bodies and certified by them are subject to the provisions of Section 2, D.3. In such cases **TL** reserves the right to demand that supplementary production tests be carried out before the start of fabrication or during production.

**1.4** In individual, technically justified exceptional circumstances (e.g. repairs), the Surveyor may, subject to a specified time limit and to limitation to a particular structure, authorise the use of particular welding processes without carrying out a welding procedure test beforehand, provided that proof is furnished by means of other suitable tests (e.g. non-destructive weld tests

and/or production tests) that the welding process in question is being applied correctly and safely.

### 2. Preliminary Welding Procedure Test

**2.1** A preliminary welding procedure test shall be carried out on the premises of manufacturers of welding equipment or welding consumables or at research institutions if, for special reasons, an immediate welding procedure test in the user's works appears inappropriate.

In this test, the welding parameters and, where applicable, the post-weld heat treatments shall conform to the conditions prevailing in the user's works. In all other respects, the provisions governing welding procedure tests in the user's works apply.

**2.2** The preliminary welding procedure test does not relieve the user's works of the obligation to carry out a definitive welding procedure test. On the basis of the preliminary test, a simplified test schedule for the definitive welding procedure test may be accepted.

### 3. Production Tests

**3.1** Production tests shall be performed to the extent described in Section 12 to 16 in the course of fabrication to monitor the quality of the welded joints. Test pieces welded at the same time as the production welds (e.g. in the course of a longitudinal weld of a plate, pipe or vessel shell ring) or sections of production welds may be used for this purpose. Where applicable, the test pieces shall as far as possible be heat-treated together with the component. As a rule, the production tests shall comprise both non-destructive tests and mechanical and technological tests.

**3.2** Production tests are also required if a particular welding process has not been used under the **TL**'s supervision for a long time or if processes and/or materials to be welded require constant verification of the weld quality. The nature and scope of such production tests shall be established on a case-by-case basis.

**3.3** In addition, **TL** may require production tests to be carried out if the way in which the welding work is

performed gives rise to doubts as to the quality of the welded joints or if individual welding parameters, welding consumables or auxiliary materials have been changed or changes have been made in the welding shop personnel. The scope of such production tests will be established on a case-by-case basis.

**3.4** For production tests in conjunction with overweldable shop primers, please refer to Section 6, C.

## **B. Performance of Welding Procedure and Production Tests**

### **1. Application for Approval**

**1.1** Application for approval of a welding process and for the performance of a welding procedure test shall be made to TL's head office, with simultaneous notification of the competent Surveyor, giving the following.

- Range of application (components, materials, plate/wall thicknesses, pipe diameters, weld factor where applicable),
- Welding process,
- Welding positions,
- Welding equipment and parameters,
- Weld shapes, weld build-up,
- Welding consumables and auxiliary materials,
- Joint preparation,
- Cold- or hot-forming operations prior to welding,
- Overweldable shop primers
- Welding jigs and weather protection,
- Preheating and heat input during welding,

- Post-weld heat treatment, other after-treatment,
- Welders (qualification tests),
- Date of test.

*Note:*

*The welding procedure (WPS) and recording the test results (WPAR) in conformity with EN ISO 15609-1, 2, EN ISO 15614-1.*

**1.2** Where possible, the application should enclose a proposal for a test schedule in accordance with the rules with sketches and dimensions of the test pieces, describing the intended specimens and tests. If the information and parameters stipulated in 1.1 are based on in-house standards or other (welding) specifications, these are also to be enclosed with the application.

### **2. Scope of Testing, Requirements, Test Schedule**

**2.1** The scope of testing (test pieces, specimens, etc.), tests and requirements for the individual fields of application (shipbuilding, steam boiler and pressure vessel fabrication, pipeline fabrication, etc.) are described in Section 12 to 16 while details of the non-destructive tests are given in Section 10 and details of the mechanical and technological tests in Section 11.

**2.2** If a test schedule appropriate to the intended field and range of application has already been drawn up by the applicant in accordance with 1.2 and 2.1 as applicable, this must be agreed with TL before starting the tests. Otherwise such a test schedule must be drawn up by the applicant - with the agreement of TL - and submitted to the TL's Head Office for final authorisation.

### **3. Materials, Welding Consumables and Auxiliary Materials**

**3.1** The materials used in the welding procedure tests must be unambiguously identifiable on the basis of their marking and certificates. The direction of rolling of the test pieces must be ascertainable. If not, check specimens shall be prepared and tested.



**3.2** The welding consumables and auxiliary materials should if possible have already been tested and approved by **TL**; however, they may be tested and approved at the same time as the welding process (see Section 5, A.1.4). Approvals of this type are generally restricted to the user's works and are valid for a maximum of one year, unless repeat tests are performed in accordance with Section 5, A.3.

**3.3** Welding consumables and auxiliary materials used in the welding procedure tests may only be replaced in the subsequent fabrication work by others of the same kind which bear **TL**'s approval if this is expressly stated in welding procedure approval certificate (see also A.3.3).

#### **4. Test Pieces, Dimensions, Direction of Rolling, Weld Form, Welding Positions**

**4.1** The shape and size of the test pieces shall be compatible with the welding procedure concerned and the number of specimens. The most commonly used test pieces are described in Section 12 to 16. The dimensions of the test pieces may be changed if this does not adversely affect the test and is necessary for evaluating the process. Unless otherwise stipulated in an individual case both butt welded and fillet weld test pieces shall be welded in the specified positions for the fabrication process.

**4.2** For vertical welding (e.g. electro gas or electroslag welding) the length of the test piece (length of the weld) shall conform to the production welding jig, while with appliances using a fusible wire-guide electrode, the length of the test piece shall be geared to the length of the wire-guide electrode or the height of the components to be welded, as applicable. Any special features affecting the application of these processes (e.g. welding operations performed through the deck) shall be allowed for in determining the shape of the test piece.

**4.3** The plate thicknesses shall be chosen in accordance with the information on the limits of application in Section 12 to 16 line with the intended range of application. Where possible, two different plate thicknesses should be welded and tested for each range of application. The weld form shall be those to be used in subsequent practice in line with the welding process.

**4.4** Where the characteristics of the welding process or the dimensions, and hence the number of passes which these entail, are likely to have a considerable effect on the results of the test, the thickness of the test pieces and the number of passes shall be made to conform to the limit thicknesses for the range of application concerned. In the case of vertical downward welding, the thickness of the test piece shall be the upper limit thickness of the range of application, whereas with a variable number of passes depending on the plate thickness (e.g. with single- and multi-pass welding) the scope of the test shall include the various techniques and the thickness of the test pieces shall be chosen accordingly. The same applies in analogous manner to the weld thicknesses.

**4.5** Normally, test pieces shall be welded in all the positions occurring in subsequent practice. Depending on the welding processes and materials concerned, it may be agreed to restrict the test to certain specified welding positions, e.g. in the case of manual arc welding or semi-mechanised gas-shielded metal arc welding the test may be limited to the positions applicable to the corresponding welder's qualification tests as stated in Section 3. The horizontal-vertical position PC (h-v) is, however, always to be included in the welding procedure test for single-side welding. Where overhead welding PE (o) is included, this may be combined with the down hand position PA (d).

**4.6** The direction of rolling of the plates shall be parallel to the direction of welding. The orientation of the rolling direction shall be stated in the test report.

#### **5. Welding of Test Pieces**

**5.1** All welding procedure tests shall investigate, in accordance with workshop practice, the effects of prior cold-forming operations, weld preparation as practised in the welding shop and air gap exactness, restraints together with the use, where applicable, of overweldable production coatings (shop primers).

Difficult fabrication conditions (e.g. limited accessibility) shall be simulated in the welding procedure test.

**5.2** Welding shop facilities, welding equipment, aids to assembly and tack welds used in the test shall

conform to those used in actual production. In the downhand and vertical positions, account is to be taken of the maximum anticipated angular deviations from the theoretical welding position (e.g. slope of slipway).

**5.3** Where possible, several (at least two) welders or two teams of operators shall participate in a welding procedure test. As part of the welding procedure test, each welder or team of operators, as applicable, shall carry out anew the preparation (tack welding) of the test pieces, the alignment of the welding appliances, and the setting of the current supply and feed rate.

**5.4** Preheating, heat input per unit length of weld, interpass temperature, electrode changing and the starting and stopping of welding appliances (starting points/end craters) shall conform to subsequent practice. Covered electrodes are to be used down to the clamping butt.

**5.5** In welding procedure tests, depositing a backing run on the root side with or without grooving of the root depending on the process, are generally permitted. In single-side welding, the same types of backing shall be used as in the subsequent fabrication work.

**5.6** In the case of mechanised welding processes in shipbuilding, an interruption of the welding operation followed by complete cooling of the test piece and restarting of the equipment shall be demonstrated. The machining of the end crater and the preparation of the new starting point shall be carried out in accordance with normal practice. The test results from these weld areas will be evaluated separately.

**5.7** Minor welding defects occurring in the course of a welding procedure test may, with the consent of the Surveyor, be repaired or ignored when preparing specimens. In the case of serious defects, the causes shall be established and remedied, after which new test pieces shall be welded.

**5.8** The following data shall be recorded when welding the test pieces:

- Weld build-up and number of passes,
- Welding consumables and auxiliary materials (type, trade name, dimensions, quantities),
- Method of root grooving and interpass cleaning/ treatment,
- Preheating, interpass temperatures,
- Welding equipment and parameters (amperage, voltage, welding speed, heat input per unit length of weld),
- Interruptions/disturbances in the welding sequence,
- Names of welders/operators,
- Special features applying to the tests (e.g. climatic influences, limited accessibility).

## **6. Post-weld Heat Treatment, Other Kinds of After-Treatment**

**6.1** If post-weld heat treatment of the components (e.g. annealing to relieve stresses) is intended in the subsequent fabrication work, the test pieces are to be subjected to the same post-weld heat treatment. This applies in analogous manner to other types of after-treatment, e.g., TIG after-treatment of the weld interfaces. If approval of the welding process is desired for both the untreated and after-treated conditions, the test shall be carried out for both conditions.

**6.2** Where possible, post-weld heat treatment of the test pieces should be carried out in the annealing furnaces which are to be used for the fabricated components. The equipping of the annealing furnace with a temperature recorder is mandatory. The time-temperature curve shall be recorded. Other types of after-treatment shall be described in the test report. Further information on post-weld heat treatment is given in Section 9.

## **7. Non-Destructive Testing**

**7.1** Prior to sectioning, each butt-welded test

piece shall undergo visual and non-destructive testing over the entire length of the weld to detect any external or internal welding defects. Unless otherwise agreed, the test pieces shall be radiographed and those with a thickness of 30 mm or over (10 mm or over in the case of single-side submerged-arc welded test pieces) shall additionally undergo ultrasonic testing.

**7.2** Where the base materials or weld metals are liable to crack, surface testing for cracks shall be carried out in addition to the above. If the material is magnetizable, this shall take the form of magnetic particle inspection; otherwise the dye penetrant method shall be used. **TL** may require specific testing intervals (e.g. 72 hours) to be adhered to between completion of the welding work and performance of the crack tests.

**7.3** Each K-shape or fillet-weld test piece (T-joint or cruciform test piece) shall undergo a visual inspection for external welding defects. Test pieces made from a material other than normal-strength hull structural steel or comparable simple structural steels shall in addition be subjected to testing for surface cracks.

**7.4** In contrast to the recording limits stated for the production tests, all welding defects and indications detected during non-destructive ultrasonic testing shall be recorded.

## **8. Sectioning of Test Pieces, Preparation of Specimens**

**8.1** Sectioning of the test pieces shall be carried out as described in Section 12 to 16. The test pieces shall be sectioned mechanically. If thermal cutting methods are employed, a sufficient machining allowance shall be provided and the heat-affected zone must thereafter be machined off.

**8.2** The individual specimens shall be marked before sectioning and during machining in a way which enables them to be identified at all times and their orientation in the test piece to be reconstructed.

**8.3** From all butt-welded and fillet-welded (cruciform) test pieces for manual and semi-mechanised welding processes, one set of specimens each shall normally be taken and tested. From the test pieces for fully mechanised welding processes, one set of speci-

mens each from the beginning and end of the weld shall be taken and tested. In the case of these latter test pieces, a third set of specimens from the middle of the weld may be additionally demanded in special circumstances, e.g. where long seams are concerned or the welding process has been recently developed. Where single-side submerged-arc welding is performed with flux backing, a third set of specimens shall be subjected to test in every case.

## **9. Shapes and Dimensions of Test Specimens, Mechanical and Technological Tests**

**9.1** The shapes and dimensions of the specimens, the preparation and performance of the tests and the determination of the results are subject to the provisions of Section 11. Furthermore, the corresponding provisions in the Rules for Materials (Section 1 and 2) shall also be complied with.

**9.2** All tests shall be carried out by trained staff using calibrated testing equipment. The testing equipment shall be maintained by its owners in fully functional condition and shall be calibrated at regular intervals by an independent testing body.

**9.3** Unless otherwise stipulated or agreed, all mechanical and technological tests shall be performed in the presence of the competent Surveyor. The micrographs shall be submitted to him for evaluation.

## **C. Evaluation of Test Results, Requirements, Repeat Test Specimens, Test Reports**

### **1. Designation of Test Results**

**1.1** To ensure that the description and evaluation of welding processes and positions, test results, etc. are as clear and uniform as possible, use shall be made of the terminology and symbols in the relevant standards (e.g. ISO 857-1, EN ISO 6947, ISO 6520-1, ISO 5817, ISO 10042) and, for internal defects, Table 10.1 in Section 10. The position of a defect or fracture must be indicated and may be designated as follows:

WM = In the weld metal

FL = In the transition zone (fusion line)

HAZ = In the heat-affected zone (of the base material)

BM = In the base material.

## 2. Requirements, Repeat Test Specimens

2.1 The requirements are specified in Section 12 to 16.

2.2 If, in the tests, individual specimens fail to meet the requirements or the failure of these specimens is due to localised defects in the specimen or deficiencies in the testing equipment, it is sufficient to test two repeat test specimens or sets of repeat specimens in each case from the same test piece, which must then meet the requirements.

2.3 In the testing of notched bar impact test specimens, unless otherwise specified in a particular case, the average value of three specimens shall apply; none of the individual values may be less than 70 % of the required value. If these conditions are not met and the average value is not less than 85 % of the required value, three repeat test specimens may be tested and the results added to the values originally obtained. The new average value from these six specimens must then meet the requirements. If the average value of the first three specimens is less than 85 % of the required value, six repeat test specimens shall be tested, the average value of which must meet the requirements.

2.4 If the requirements are not met by a sizeable number of specimens and/or in several areas of testing, the causes of the failures shall be investigated. When the faults have been cured, new test pieces shall be welded and fully tested.

## 3. Reports, Storage Times

3.1 Reports shall be prepared of all trial welds and tests and submitted to **TL** in duplicate, signed by the tester and the testing supervisor.

3.2 The debris of test pieces, specimens and the test documentation are to be kept until all the tests and inspections are concluded by the confirmation of approval issued by **TL**. For the storage time of documents

relating to the non-destructive testing of welds (e.g. radiographs), see Section 10.

## D. Limits of Application, Period of Validity

### 1. Works and Sub-Works

1.1 Welding procedure approvals are generally non-transferable. **TL** may allow exceptions in the case of a nearby branch works where the welding work is carried out under the constant supervision of the main works, provided that the fabrication work is performed under the same conditions and the same specified welding processes are used. **TL** may, however, require proof as to whether the welding processes are being applied correctly and the mechanical properties are adequate by means of nondestructive tests and/or simplified production tests.

1.2 Welding procedure tests performed in a workshop are in general not simultaneously valid for welding in the field. In such cases, the welding procedure test must be repeated in full or in part under field conditions as determined by **TL**. **TL** may dispense with repeat testing by prior agreement if the qualitative properties of the field welds are demonstrated by production tests.

### 2. Range of Application

2.1 The other materials included in a welding procedure approval on the basis of the testing of a particular material are indicated in Section 12 to 16.

2.2 With regard to plate thicknesses, unless otherwise stated in Section 12 to 16 or in a particular case a plate thickness range of approx. 0,7 - 1,7 t (t = tested plate thickness) shall apply to hull structures according to Section 12 and a range of 0,75 - 1,5 t shall apply in the other fields of application. **TL** may limit this range of application, in accordance with the standards (EN ISO 15614-1), to 0,8 - 1,1 t or extend it to 0,5 - 2 t. In the case of vertical downward welding, the thickness of the plate tested shall in each case be regarded as the upper limit of application.

2.3 The welding procedure approval is generally

valid for the welding positions tested. Depending on the welding process, particular welding positions may be included; these are stated in the approval document where applicable.

**2.4** The welding procedure approval is valid for the welding process, the weld form and weld build-up tested.

**2.5** The welding procedure approval is valid for the heat treatment condition for which the test was performed, e.g. untreated, annealed to relieve stresses, normalised.

**2.6** Any minimum or maximum design or operating temperatures taken into account during testing are stated in the procedure approval document. (The former is generally 5°C above the test temperature.)

### **3. Period of Validity**

**3.1** A welding procedure approval is generally valid without limit of time or with a time limit - depending upon the range of application; see Table 4.1 and Section 12 to 16. This is, however, always provided that the conditions under which it was granted do not change significantly.

**3.2** The welding procedure approval is tied to the approval of the welding shop to perform welding work and expires when the approval of the welding shop expires. For renewal of the welding shop approval document (see Section 2, A.4.), it must be demonstrated to **TL** that the approved welding processes have not be changed in the current production run and have been used without any significant defects.

**3.3** For the production tests necessary in individual fields (e.g. steam boiler, pressure vessel) of application to maintain the validity of a welding procedure approval, please refer to A.3. **TL** will check the aforementioned conditions in the course of the three-yearly renewal of the welding shop approval; see Section 2.

**3.4** **TL** may revoke part or all of a welding procedure approval and require a fresh welding procedure test or fresh production tests if doubts arise as to whether a welding process is being applied correctly or safely or if defects in or damage to the welds made by this process lead to the conclusion that the quality of the welded joints is inadequate.

**Table 4.1 Recognition (qualification) of welding processes – summary**

Range of application	Welding of hull structures		Welding of steam boilers	Welding of pressure vessels	Welding of pipelines		Welding of machinery components	
	Components	Hull structures, and equipment parts used in shipbuilding	Pressure bearing parts & parts welded to them	Pressure bearing parts & parts welded to them	Pipe class III	Pipe classes I-II	Bedplates, pedestals, gearbox, casings, wheel bodies, auxiliary deck machinery etc.	
Form and principles for acceptance	Acceptance of "standard procedures" or based on experience	Acceptance based on welding procedure tests	Acceptance based on welding procedure tests	Acceptance based on welding procedure tests	Acceptance of "standard procedures" or based on experience	Acceptance based on welding procedure tests	Acceptance of "standard procedures" or based on experience	Acceptance based on welding procedure tests
TL Welding Rules / Chapter/Section :	3/4, A.1.2 and 3/12, B.3	3/4 and 3/12, F	3/4 and 6/2, F	3/4 and 6/3, F	3/4, A.1.2 and analogously 3/12, B.3	3/4 and 6/4, G	3/4, A.1.2 and analogously 3/12, B.3	3/4 and 6/5, F
Relevant ISO/EN/DIN standard: rule:	EN ISO 15611 and 15612	EN ISO 15614-1 and 15614-2	EN ISO 15614-1, TRD 201 Annex 1	EN ISO 15614-1 and 15614-2, AD-HP 2/1	EN ISO 15611 and 15612	EN ISO 15614-1 and 15614-2	EN ISO 15611 and 15612	EN ISO 15614-1 and 15614-2
General preconditions	Approved welding shops, recognised welding supervisors, welders certified to ISO 9606 / DIN EN 287; certified materials from approved manufacturers approved welding consumables and auxiliary materials; authorized welding procedure specifications conforming to EN ISO 15607- EN ISO 15614							
Materials	Normal-strength hull structural steels	All others (See Sec.12, F.1.3 footnote (1)).	All	All	Unalloyed steels TL strength grade 360 and 410 (S 295)	All others (see Sec.12, F.1.3 footnote (1))	Normal-strength hull structural steels and comparable unalloyed structural steels, e.g. S 235	All others (see Sec.12, F.1.3 footnote (1))
Plate/wall thickness; pipe diameters	Depending on the scope of the applicable welder's qualification tests. UP-T; 4-25-M; -40 mm.	All	All	All	Depending on the scope of the applicable welder's qualification tests	All	Depending on the scope of the applicable welders qualification tests SAW-T; 4-25-M; -40 mm.	All
Welding process	E-manual, MAG-M and C (solid and flux-cored wire electrodes), together with single wire submerged arc. Except for single side welding	All others (See Sec.12, F.1.3 footnote (2))	All	All	Manual (incl. TIG) and semimechanised welding processes; others as for pipe cl. I-II	All	E-Manual MAG-M and C (solid and flux-cored wire electrodes), together with single wire submerged arc. Except for single-side welding	All others (see Sec.12, F.1.3 footnote (2))
Welding positions	All except for PG (v-d) PA (d) only for submerged arc	All	All	All	All except for PG (v-d)	All	All except for PG (v-d) PA (d) only for submerged arc.	All
Validity	Generally not subject to time limit	Generally not subject to time limit	1 year	1 year	Generally not subject to time limit	1 year	Generally not subject to time limit	Generally not subject to time limit
Extension based on	Proof according to D.3.2	Proof according to D.3.2	Production tests or repeat welding procedure test	Production tests or repeat welding procedure test	Proof according to D.3.2	Proof of quality e.g. NDT, or repeat welding procedure test	Proof according to D.3.2	Proof according to D.3.2

## SECTION 5

## WELDING CONSUMABLES AND AUXILIARY MATERIALS

<b>A.</b>	<b>GENERAL .....</b>	<b>5- 3</b>
	1. Approval Procedure	
	2. Transfers of Approval	
	3. Period of Validity and Repeat Tests	
	4. Classification and Designation (Quality Grades, Added Symbols)	
	5. Upgrading and Downgrading	
	6. Physical Characteristics, Welding Performance and Packaging	
	7. Performance of Approval Tests	
	8. Mechanical Testing Procedure	
<b>B.</b>	<b>COVERED ELECTRODES FOR MANUAL METAL-ARC WELDING OF HULL STRUCTURAL STEELS.....</b>	<b>5-14</b>
	1. General	
	2. Testing the Weld Metal	
	3. Testing on Welded Joints	
	4. Hot-Cracking Test	
	5. Hydrogen Test	
	6. Covered electrodes for manual fillet welding	
	7. Covered electrodes for gravity or contact welding	
	8. Annual Repeat Tests and upgrading	
<b>C.</b>	<b>(FLUX-CORED) WIRE-GAS COMBINATIONS AND FLUX-CORED WIRE ELECTRODES FOR SEMI-MECHANIZED WELDING OF HULL STRUCTURAL STEELS .....</b>	<b>5-24</b>
	1. General	
	2. Testing the Weld Metal	
	3. Testing on Welded Joints	
	4. Hydrogen Test	
	5. Hot-cracking Test	
	6. Annual Repeat Tests	
<b>D.</b>	<b>WIRE-FLUX COMBINATIONS FOR SUBMERGED-ARC WELDING OF HULL STRUCTURAL STEELS .....</b>	<b>5-29</b>
	1. General	
	2. Testing the Weld Metal	
	3. Testing on Welded Joints	
	4. Hydrogen Test	
	5. Annual Repeat Tests	
<b>E.</b>	<b>WELDING CONSUMABLES AND AUXILIARY MATERIALS FOR ELECTROGAS AND ELECTROSLAG WELDING OF HULL STRUCTURAL STEELS.....</b>	<b>5-35</b>
	1. General	
	2. Testing on Welded Joints	
	3. Annual Repeat Tests	
<b>F.</b>	<b>WELDING CONSUMABLES AND AUXILIARY MATERIALS FOR HIGH-STRENGTH (QUENCHED AND TEMPERED) STRUCTURAL STEELS .....</b>	<b>5-37</b>
	1. General	
	2. Testing of the Weld Metal	
	3. Testing on Welded Joints	
	4. Hydrogen Test	
	5. Annual Repeat Tests	

<b>G.</b>	<b>WELDING CONSUMABLES AND AUXILIARY MATERIALS FOR STEELS TOUGH AT SUBZERO TEMPERATURES</b> .....	<b>5-40</b>
	1. General	
	2. Testing of the Weld Metal	
	3. Testing on Welded Joints	
	4. Hydrogen Test	
	5. Annual Repeat Tests	
<b>H.</b>	<b>WELDING CONSUMABLES AND AUXILIARY MATERIALS FOR HIGH-TEMPERATURE STEELS</b> .....	<b>5-42</b>
	1. General	
	2. Testing the Weld Metal	
	3. Testing on Welded Joints	
	4. Hydrogen Test	
	5. Testing for Hot Cracks	
	6. Annual Repeat Tests	
<b>I.</b>	<b>AUSTENITIC AND AUSTENITIC-FERRITIC WELDING CONSUMABLES AND AUXILIARY MATERIALS FOR STAINLESS STEELS, NON-MAGNETIC STEELS AND NICKEL ALLOY STEELS TOUGH AT SUBZERO TEMPERATURES</b> .....	<b>5-45</b>
	1. General	
	2. Testing of the Weld Metal	
	3. Testing on Welded Joints	
	4. Testing of Resistance to Intergranular Corrosion	
	5. Testing for Hot Cracks	
	6. Annual Repeat Tests	
<b>J.</b>	<b>WELDING CONSUMABLES AND AUXILIARY MATERIALS FOR ALUMINIUM ALLOYS</b> .....	<b>5-50</b>
	1. General	
	2. Testing of the Weld Metal	
	3. Testing on Welded Joints	
	4. Annual Repeat Tests	
<b>K.</b>	<b>WELDING CONSUMABLES AND AUXILIARY MATERIALS FOR COPPER AND COPPER ALLOYS</b> .....	<b>5-54</b>
	1. General	
	2. Testing of the Weld Metal	
	3. Testing on Welded Joints	
	4. Annual Repeat Tests	
<b>L.</b>	<b>WELDING CONSUMABLES AND AUXILIARY MATERIALS FOR NICKEL AND NICKEL ALLOYS</b> .....	<b>5-54</b>
	1. General	
	2. Testing of the Weld Metal	
	3. Testing on Welded Joints	
	4. Annual Repeat Tests	



## A. General

Requirements of this section give the conditions of approval and inspection of welding consumables used for hull structural steel welding as follows:

- Normal strength steels Grades A, B, D and E ,
- Higher strength steels Grades A32, D32, E32, A36, D36 and E36,
- Higher strength steels with minimum yield strength 390 N/mm<sup>2</sup>: Grades A40, D40 and E40,
- Higher strength steels for low temperature application: Grades F32, F36 and F40.

Welding consumables for high strength quenched and tempered steels for welded structures according to Chapter 2 Material Section 3, C are subject to special consideration by the TL.

These requirements are not applicable for welding procedure qualification tests at the shipyard.

### Categories of products

The concerned welding consumables are divided into several categories as follows:

- Covered electrodes for manual welding and gravity welding,
- Wire/flux combinations for two run or multirun submerged arc welding,
- Solid wire/gas combinations for arc welding,
- Flux cored wires with or without gas for arc welding,
- Consumables for use in electroslag and electrogas vertical welding

### Manufacture

The manufacturer's plant, methods of production and quality control of welding consumables are to be such

as to ensure reasonable uniformity in manufacture.

## 1. Approval Procedure

**1.1** All welding consumables and auxiliary materials (welding wires and rods, covered electrodes, flux cored wires, (flux cored-) wire-gas or wire-flux combinations, etc.) which are to be used within the range of approval of the Welding Rules or other Rules, regulations, etc. issued by TL must be tested and approved by TL for that purpose in accordance with the following provisions. The same also applies in an analogous manner to brazing materials, the tests and requirements for which will be specified on a case-by-case basis.

**1.2** Approval is normally granted on the basis of specimen welds and tests carried out on the weld metal and the weld joints on the manufacturer's premises under TL's supervision with each individual product (individual manufacturer's brand) in accordance with 1.1, for which approval was applied for. For details of transfers of approvals, see 2.

When a welded joint is performed, the edges of the plates are to be bevelled either by mechanical machining or by oxygen cutting; in the later case, a descaling of the bevelled edges is necessary.

The welding conditions used such as amperage, voltage, travel speed, etc are to be within the range recommended by the manufacturer for normal good welding practice. Where a filler material is stated to be suitable for both alternating current (AC) and direct current (DC), AC is to be used for the preparation of the test assemblies.

**1.3** An inspection of the manufacturer's production facilities (production workshops, stores etc.) and especially the internal quality assurance measures applied shall be carried out in the course of normal production in conjunction with the approval tests.

#### Note:

1. *The quality requirements relating to the manufacture, supply and marketing of welding consumables and the processes applied are described in EN 12074/ISO*

14344. Unless other or contrary provisions relating to this are stipulated in the following items, the quality requirements stated in this standard may be used as a basis for the inspection of the manufacturer's facilities.

2. IACS Rec.17 can be used for the Acceptance of Manufacturer's Quality Assurance Systems for Welding Consumables as a guidance.

**1.4** The Surveyor is to be satisfied that the manufacturer's plant, methods of production and quality control of welding consumables are to be such as to ensure a reasonable uniformity in manufacture, as mentioned above.

**1.5** For the approval of welding consumables and auxiliary materials in conjunction with a (preliminary) welding procedure test, see also Section 4, B.3.2. The user must have consented to the approval (on behalf of the manufacturer). In such cases the testing of the pure weld metal shall also be included in the scope of the welding procedure tests. Testing of specimens taken from the welded joint is not regarded as testing of the pure weld metal.

Where approval is applied exclusively for auxiliary materials such as ceramic backing strips (i.e. not in conjunction with welding consumables), their properties shall be tested, and where appropriate their effect on the quality of the welded joints established on the basis of the relevant product standards or the manufacturer's specifications in accordance with a test schedule to be specified in each individual case.

**1.6** If welding consumables and auxiliary materials are to be approved in exceptional cases on the basis of approval tests conducted elsewhere by other bodies recognized by TL (e.g. IACS member classification societies, accredited technical supervisory authorities,) the complete test reports shall be submitted (initial test not older than 5 years and, if applicable, the last 3 annual repeat tests) and if nothing else has been stipulated by TL tests at least corresponding to the compulsory (annual) repeat tests shall be performed.

**1.7** In isolated, urgent cases, consent may

exceptionally be given for the use of welding consumables and auxiliary materials which have been approved by IACS member classification societies or neutral testing authorities (e.g. accredited technical supervisory authorities), though such consent shall be subject to a time limit and shall be restricted to a particular structure. In the case of larger projects, the manufacturer shall simultaneously apply for approval.

**1.8** Applications for approval shall be submitted in one copy to TL's head office, with simultaneous notification of the competent Surveyor, giving the following information and accompanied by the most recent catalogues resp. technical data sheets with the properties guaranteed by the manufacturer (especially chemical composition, strength and toughness values):

- Manufacturer's name and manufacturing works (name of licensor, where appropriate),
- Nature of the welding consumables and auxiliary materials,
- Manufacturer's brand (licensor's designation, where applicable),
- Dimensions for which approval is applied for (diameters, lengths),
- Grades for which application is made, including additional symbols,
- Proposed range of application, including for example base materials, welding processes, welding positions for which approval is sought, heat treatment condition and any special operating conditions (e.g. low temperatures),
- Instructions for use (welding current, polarity, baking, heat treatment, etc.),
- Classification to DIN, EN, ISO, TSE, AWS or other standards,
- Marking, packaging,
- Any previous approvals (e.g. from IACS member classification societies, accredited technical supervisory authorities),

- Proposed testing laboratory and date of test.

The statements of conformity ("Affidavits") specified in 2.2 shall also be enclosed with any application for transfer of approval.

**Note:**

*Classification to DIN, EN, ISO, TSE, AWS or other standards is performed by the manufacturer and is included in the approval certificate and in the list of welding consumables and auxiliary materials approved by TL. Where possible classification is performed to EN standards, but where these are not well-known classification shall be to other rules which have the widest possible circulation. For space reasons, however, only the designation of the standard is generally given in the list (not the title of the relevant standard). Classification is not normally covered by the tests and is therefore not part of the approval granted TL; see 4. If TL is also required to check and confirm the classification in accordance with the standards, a separate application should be made to this effect.*

**1.9** The applicant is generally the manufacturer of the welding consumables and auxiliary materials. The manufacturer is the firm which carries out the final quality-influencing stage of the manufacturing process (e.g. coiling in the case of wire electrodes).

**1.10** In the case of applicants with several production facilities which have separate organisations and are in separate locations, approval of the welding consumables and auxiliary materials will generally be granted for the plant that manufactured them. If production is relocated, already existing approvals may be transferred to the new plant. The conditions relating to the transfer of approvals specified in 2. shall apply in an analogous manner hereto.

When a filler product is manufactured in several factories of the same company, the complete series of approval tests should be carried out in one of the works only. In the other factories, a reduced test programme at least equivalent to annual tests is permitted if the manufacturer can certify that the materials used and the fabrication process are identical with those used in the main works.

This requirement is applicable to all manufacturers of filler products under license (sister firms). However, symbols must be visible. The details given in the current

should there be any doubt, complete test-series may be required.

**Note:**

*Wire flux combination for submerged arc welding. If a unique powder flux is combined with different wires coming from several factories belonging to the same firm, it may be admitted to perform only one test-series if the different wires are conformable to the same technical specification, after approval of TL.*

**1.11** If the applicant is not the manufacturer of the welding consumables and auxiliary materials, he shall give TL the names of his suppliers. Any change of supplier shall be promptly notified to TL and generally necessitates a fresh approval test.

**1.12** If welding consumables of the same composition are manufactured by several suppliers and marketed by the applicant under a brand name, the inhouse records and the printing on the packaging (e.g. fabrication number) must clearly identify the manufacturer in question beyond all doubt. The relevant code system used must be notified to TL.

**1.13** On the successful conclusion of the specimen welds and tests, TL's head office will issue an approval certificate. TL also maintains and publishes a "List of Approved Welding Consumables".

**1.14** With the approval, the manufacturer assumes responsibility for ensuring that during fabrication, the composition and properties of the products conform at all times to those of the tested welding consumables and auxiliary materials; see also Section 1, F.1., and under 3.2.

**1.15** Manufacturers are obliged to state in their catalogues at least those items of information from the approval certificate which appear in the "List of Approved Welding Consumables".

**1.16** Besides the brand name, identifying marks and the manufacturer's details concerning the nature and use of the welding consumable or auxiliary material, the printing on the packaging or the adhesive label or the tag attached to reels, coils of wire etc. must at least indicate TL's full quality grade and any additional approval list published by TL in accordance with 1.14

shall, however, take precedence in each case.

**1.17** Where possible each individual covered electrode, welding wire etc. shall be permanently and distinctively identified by colour-coding, stamping or impressed marking. The marking must match that on the packaging.

## 2. Transfers of Approval

**2.1** On application, an "original approval" once granted may be transferred to welding consumables and auxiliary materials manufactured in the same works but bearing a different brand designation or to welding consumables and auxiliary materials with the same or a different brand designation and produced by other manufacturers (including subsidiary companies) under licence. An approval which has already been based on a transfer of approval cannot be transferred.

**2.2** For this purpose, manufacturing and marketing companies as well as licensors and licensees must confirm that the welding consumables are identical in composition, manufacture and the welding properties and quality factors on which approval was based ("Affidavits"), and they must constantly supervise that this identity is preserved in accordance with 1.15 Marketing companies are also required to confirm that other welding consumables and auxiliary materials (from

other manufacturers) are not marketed under the same brand name; see 1.10 to 1.2 and the note to 3.3.

**2.3** Transfer of approval is normally conditional upon a previous test corresponding in scope to the prescribed (annual) repeat test. However, a test differing from this in scope and timing may be agreed. A test may be waived where the transfer relates to welding consumables and auxiliary materials manufactured in the same works provided that the prescribed (annual) repeat tests were performed on the manufacturer's premises in the period stipulated.

**2.4** The company (marketing company, licensee) in whose name the approval certificate has been issued is responsible for the prescribed (annual) repeat tests. Where welding consumables and auxiliary materials are produced in the same works, repeat tests need not be duplicated, but where welding consumables of the same composition are manufactured by several suppliers repeat tests are required for all suppliers.

**2.5** Changes to welding consumables and auxiliary materials or their brand designations, the relocation of manufacturing facilities, or changes in the relationship existing between companies (e.g. in the case of transfers of approval) shall be brought to TL's attention by each of the companies concerned. The provisions of 1. are to be applied in analogous manner.

**Table 5.1 Welding positions**

Code No.	Welding positions	Code letters
1	All welding positions	PA (d), PB (h), PC (h-v), PD (h-o), PE (o), PF (v-u), PG (v-d)
2	All except the vertical-down position	PA (d), PB (h), PC (h-v), PD (h-o), PE (o), PF (v-u)
3	Butt welds in the down-hand position, fillet welds in the down-hand and horizontal positions	PA (d), PB (h)
4	Butt welds in the down-hand position and fillet welds in the down-hand position	PA (d)
5	Vertical down-positions and those as for code no. 3	PA (d), PB (h), PG (v-d)

### 3. Period of Validity and Repeat Tests

**3.1** The production techniques and associated quality control procedures at all establishments approved for the manufacture of welding consumables are to be subjected to an annual re-appraisal. On these occasions, samples of the approved consumable are to be selected by the Surveyor and subjected to the tests detailed in subsequent sections of these Requirements.

These are to be completed and reported within the one year period beginning at the initial approval date, and repeated annually so as to provide at least an average of one annual test per year.

Provided that the prescribed (annual) repeat tests are performed, approvals of welding consumables and auxiliary materials remain valid indefinitely until revoked. If welding consumables and auxiliary materials do not undergo the prescribed annual repeat tests, the approval shall lapse and they shall be removed from the list of approved products. Equivalent alternative documentary proof may be recognized by **TL** by prior special agreement.

*Note:*

*TL may accept regular in-house tests performed as part of a recognized quality assurance system as equivalent alternative proof provided that this system meets the recommendations "Guidelines for the Acceptance of Manufacturer's Quality Assurance Systems for Welding Consumables" which have been jointly drawn up by the IACS classification societies and that satisfactory quality assurance test records are submitted to TL for inspection at not more than yearly intervals. TL may also perform interim tests on a random basis in order to satisfy itself that the specified procedure is being followed and that the prescribed requirements are being met.*

**3.2** The continued validity of the approval is further conditional not only upon the brand designation being retained, but also upon the composition and properties of the starting and end products remaining unchanged in the intervening period, as well as upon the constant monitoring of these products by the manufacturer in accordance 1.14 and upon the maintenance of verifiable records of this monitoring. **TL** may demand sight of

these records at any time, may inspect the current production and may also, in case of doubt, call for interim sampling or testing, as appropriate.

**3.3** Transfers of approval are generally valid for a year at a time from the date of issue of the certificate, but at the most up to the (annual) repeat test at the premises of the manufacturer (licensor) which follows the issuing of the transfer certificate. Transfers of approval may be extended for a further year at a time on application by the marketing company (licensee) if both the manufacturer (licensor) and the marketing company (licensee) submit appropriate confirmations of identity (affidavits) in accordance with Section 2

*Note:*

*TL may waive the requirement for the submission of annual confirmations of identity (Affidavits) if, in conjunction with the first transfer of approval, the manufacturer (licensor) and marketing company (licensee) both expressly declare that they agree to TL continuing to certify the annual repeat test(s), (until revoked), i.e. extending the approval(s).*

**3.4** A transfer of approval to brand designations used for marketing in accordance with 2.1 shall cease to be valid when the approval of the corresponding manufacturer's product expires. A transfer of approval for a product made under licence by another manufacturer may in such cases, on application, continue to be valid, provided that the prescribed (annual) repeat tests continue to be conducted by the licensed manufacturer.

**3.5** Repeat tests shall be performed under **TL**'s supervision and shall be of the scope described for the various welding consumables and auxiliary materials. Unless otherwise agreed, the tests shall be performed at yearly intervals. They relate to a period of one year calculated from the date of the approval and are to be concluded by the end of this period at the latest. If no welding consumable or auxiliary material is manufactured within this period, i.e. is sold "ex stock" from a production run that **TL** has already inspected, **TL** may, on application, defer the repeat test. **TL** issues collective certificates covering these repeat tests.

**Note:**

If the scheduled repeat test is missed, the subsequent repeat test shall apply retrospectively to the period in which it should have been performed and may be subject to a time limit. The manufacturer is then required to perform subsequent repeat tests at shorter intervals to ensure that on average the prescribed annual test period is once again achieved. Approval is revoked if repeat testing is not performed in two consecutive years.

**3.6** Repeat tests for welding consumables and auxiliary materials which have been approved for use in both untreated condition and for one or more heat-treated conditions (see 7.4) shall be carried out according to the prescribed scope for use in untreated condition and for use in each of the heat-treated conditions in question.

**3.7** Welding consumables and auxiliary materials which have been tested and approved in conjunction with welding procedure tests conducted on the user's premises (see Section 4, B.3.2) or in conjunction with a preliminary welding procedure test (see Section 4, A.2) shall be subjected to annual repeat tests in line with these provisions, which shall be carried out on the premises of either the manufacturer or the user. In the case of welding consumables and auxiliary materials for special welding processes or materials, the scope of the tests applicable will be determined on a case-by-case basis.

#### **4. Classification and Designation (Quality Grades, Added Symbols)**

##### **4.1 Basic groups and grades**

Filler metals are mainly divided into three groups regarding their strength properties as classified below:

- Normal strength filler metals for welding normal strength hull structural steels,
- Higher strength filler metals for welding normal and higher strength hull structural steels with minimum yield strength up to 355 N/mm<sup>2</sup>,
- Higher strength filler metals for welding normal and higher strength hull structural steels with minimum yield strength up to 390 N/mm<sup>2</sup>.

Each of the three groups is based on corresponding tensile strength requirements.

Welding consumables and auxiliary materials (that are classified generally above) for the welding of hull structural steels (including the corresponding grades of steel forgings and castings) and of comparable structural steels are subject to classification, designation and approval as follows:

- According to their nature (e.g. covered electrode, fluxcored wire electrode, wire-gas combination or wire-flux combination).
- Grades 1, 2 and 3 for ordinary-strength filler metals,
- Grades 1Y, 2Y, 3Y and 4Y for higher strength filler metals for steels up to 355 N/mm<sup>2</sup> yield strength,
- Grades 2Y 40, 3 Y 40 and 4 Y 40 for higher strength filler metals for steels up to 390 N/mm<sup>2</sup> yield strength.
- With the added symbol H15(H), H10 (HH) or H5 (HHH) for controlled hydrogen content of the weld metal (applies only to quality grades 2, 3 and 4 or higher),
- With the added symbol S (= Semi-automatic) for semi-mechanized welding,
- With the added symbol T (= Two run technique) for welding in one pass on each side, M designating a multirun technique, or TM which covers both (and is applicable only to welding consumables and auxiliary materials for fully mechanized welding),
- With the added symbol V (= Vertical welding process) for electrogas or electroslag welding.

The Grade assignment is given in respect of Charpy V-notch impact test requirements.

For each strength basic group, welding consumables, which have satisfied the requirements for a higher

toughness grade are considered as complying with the requirements for a lower toughness grade.

The correlation between the hull steel grades and the welding consumables grades that must be used for the hull steel welding, is stated in the following Section 12, Table 12.1.

For welding processes where a high base material content may influence the properties of the weld metal (e.g. in submerged-arc welding using the two-run technique or in electrogas or electroslag welding), **TL** may require testing of both categories of material. Approval for semi-mechanized welding (added symbol S) subsumes approval for fully mechanized multirun welding (added symbol M) in flat positions.

**4.2** Welding consumables and auxiliary materials for the welding of high-strength (quenched and tempered) structural steels with minimum yield strengths in excess of 390 N/mm<sup>2</sup> are subject to classification, designation and approval in analogous manner to 4.1, with the following differences:

- With the quality rating 3 or higher, depending on their notch impact energy and test temperature (see F),
- With the added symbol Y and an appended code number designating the minimum yield strength of the weld metal (e.g. Y46 for a minimum yield strength of 460 N/mm<sup>2</sup>).

Each higher quality grade includes the one (or those) below. Approval for steels having the minimum yield strength designated by the code number subsumes approval for steels of similar type having the next two lower yield strengths (e.g. approval for a steel with the symbol Y50 subsumes approval for steels with the symbols Y46 and Y42). In the case of steels with minimum yield strengths of 550 N/mm<sup>2</sup> and above (symbols Y55, Y62 and Y69), the approval only subsumes the steel with the next lower yield strength. In special cases, welding consumables and auxiliary materials are approved only for specific materials.

**4.3** Depending on their nature and condition (type of alloy), welding consumables and auxiliary materials for welding of steels tough at subzero temperatures are classed as equivalent to those for high-strength (quenched and tempered) structural steels (see F), for austenitic stainless steels (see I), or for nickel and nickel alloys (see L) and are subject to classification, designation and approval as follows:

- For approvals in accordance with F., according to a quality grade which depends on their notch impact energy and test temperature and, where applicable, with the added symbol Y and the code number for the minimum yield strength (see 4.2)

or

- For approvals in accordance with I., according to a quality grade consisting of the abbreviated material number of the material or material category for which approval was granted (see 4.5), also stating the test temperature used for the approval test

or

- For approvals in accordance with L., according to a quality grade corresponding to the code designation shown in the standard applicable to the welding consumable (see 4.8), also stating the test temperature used for the approval test.

The inclusions and exclusions of the category of welding consumables and auxiliary materials according to which approval was granted apply, unless otherwise stated in the approval certificates.

**4.4** Welding consumables and auxiliary materials for welding of high-temperature steels are subject to classification, designation and approval as follows:

- According to a quality grade corresponding to the code designation for the material or material category for which the approval was granted (see H).

The materials included in the respective approvals are shown in Table 5.13.

**4.5** Austenitic welding consumables and auxiliary materials for welding of stainless and non-magnetic steels and nickel alloy steels tough at subzero temperatures are subject to classification, designation and approval as follows:

- For welded joints in (austenitic) stainless steels, according to a quality grade consisting of the abbreviated material number of the base material to be welded with the product (e.g. quality grade 4571 for the welding of steel with the material number 1.4571 X6CrNiMoTi17-12-2),
- For welded joints in (austenitic) non-magnetic stainless steels, according to a quality grade consisting of the abbreviated material number of the welding consumable itself (e.g. quality grade 3954 for the welding of steel with the material number 1.3964 X2CrNiMnMoNb21-16-5-3),
- For welded joints between these steels and unalloyed or low-alloy (hull) structural steels, for intermediate weld runs in clad plates and buildup welding, according to a quality grade consisting of the abbreviated material number of the welding consumable itself (e.g. quality grade 4370 for the welding consumable with the material number 1.4370 X15CrNiMn-18-8),
- For welding of nickel alloy steels tough at subzero temperatures, according to a quality grade consisting of the abbreviated material number of the base material to be welded with the product in question (e.g. quality grade 5662 for welding of steel with the material number 1.5662 X8Ni9).

The steels also covered by the approval and information on the types of application are shown in Subsection I (Tables 5. 16 to 5.20). In special cases, e.g. where the inclusions and exclusions differ, the relevant information is given in the approval certificates.

**4.6** Welding consumables and auxiliary materials for welding of aluminium alloys are subject to classification, designation and approval according to a quality grade corresponding to the code designation according to the standard e.g. quality grade RAlMg 4,5 Mn. For other aluminium alloys covered by the respective approval, see Table 5.21.

**4.7** Welding consumables and auxiliary materials for welding of copper and copper alloys are subject to classification, designation and approval according to a quality grade corresponding to the code designation for the welding consumable according to the standard (EN ISO 8836 or TSE equivalent), e.g. quality grade CuNi30Fe. For other base materials covered by the respective approval, see Table 5.24

**4.8** Welding consumables and auxiliary materials for welding of nickel and nickel alloys are subject to classification, designation and approval according to a quality grade corresponding to the code designation for the welding consumable according to the standard (EN ISO 14172 or TSE equivalent), e.g. quality grade NiCu30MnTi. For other base materials covered by the respective approvals, see Table 5.26.

**4.9** The code numbers and letters indicated in Table 5.1 are used to identify the approved welding positions. In special cases, the approved welding positions are specified individually; for example, an approval applicable only to the vertical-down PG (v-d) position or individual welding positions are also specified or excluded as applicable. For the limitations relating to the use of vertical-down welding, see Section 12, H.6.

**4.10** The code letters indicated in Table 5.2 are to be used to designate the type of current approved for use with the relevant welding consumables and auxiliary materials.

**Table 5.2 Type of current and polarity**

Code letter and symbol	Type of current and polarity
DC+	Direct current, + polarity
DC-	Direct current, - polarity
DC±	Direct current, + and – polarity
AC	Alternating current

## 5. Alterations, Upgrading and Downgrading

**5.1** Any alteration proposed by the manufacturer to the approved consumable which may result in a change in the chemical composition and the mechanical properties of the deposited metal, must be immediately notified to TL Additional tests may be necessary.



**5.2** The upgrading of approved welding consumables and auxiliary materials into a higher quality grade shall be applied for by the manufacturer and may suitably be effected on the occasion of the prescribed (annual) repeat tests. Upgrading requires that in addition to the repeat tests, notched bar impact test specimens shall be taken from all the butt-welded test pieces (welded joints) prescribed for the (original) approval test in the various positions and shall be subjected to test. Radiographic examination of the butt-welded test pieces is recommended.

**5.3** Downgrading into an appropriately lower quality grade results when the outcome of the prescribed (annual) repeat tests fails to fulfil the requirements, even if the retest specimens are included. Where the earlier test results and the evaluation of all the new test findings point to the likelihood that the failure of the specimens was due to defects in the material or the welding, the repeat test may be repeated at short notice. If the requirements are still not met, the quality grade will be reduced. In such a case, a renewed upgrading may take place after three months at the earliest (i.e. after thorough revision and improvement of the product) and only after testing as described in 5.2.

**5.4** The extension of an existing approval covering the welding of normal-strength hull structural steels to the welding of higher-strength hull structural steels (e.g. from grade 2 to grade 2Y or from grade 3Y to grade 3Y40) requires the performance of a complete new approval test using higher-strength hull structural steel in question as the base material. This requirement applies in analogous manner to other materials as well.

**5.5** Extension of an existing approval to include the added symbol H15(H) or the modification of the symbol H15(H) to H10(HH) or H5(HHH) is permissible provided that the weld metal can be proved to contain the stipulated lower quantity of hydrogen by a test in accordance with B.5. Corresponding tests performed elsewhere may be recognized as furnishing the necessary proof, provided that they were carried out not more than three years previously.

## **6. Physical Characteristics, Welding Performance and Packaging**

**6.1** All welding consumables and auxiliary materials must have physical characteristics compatible with

the proposed application and conforming to the relevant standards and must display a satisfactory general welding performance. The packaging must be such as to prevent excessive moisture absorption and damage to the contents provided that the materials are properly handled and stored. Verification of these characteristics and testing of the packaging form an integral part of the approval tests and repeat tests.

**6.2** In the case of covered electrodes, the coating must encase the core rod concentrically and with uniform thickness. When the electrodes are correctly used, no projecting crater rim may be formed at one side of the coating during welding. The coating shall not display any marked irregularities or surface defects. It must adhere firmly to the core rod and be capable of storage within the specified limit conditions. Subject to proper handling and use, the coating shall not rupture or break away from the core rod. The clamping butt and the arcing end must be free from coating material.

**6.3** Welding wires (wire electrodes and welding rods) must have a smooth surface and must be free from surface defects, rust or other contamination which might impair the satisfactory execution of the welding operation (e.g. by impeding the current flow). Although welding wires may be provided with metal coatings, these shall not adversely affect their welding performance or the properties of the weld. Coiled welding wires must be free from buckling and must unwind smoothly.

**6.4** Welding fluxes and shielding gases must possess a degree of purity conforming to the relevant standards together with the lowest possible moisture content. Welding fluxes should be granular in consistency and free-flowing to facilitate their smooth passage through the flux supply system. The granulometry of the flux should be uniform and constant from one package to another.

**6.5** Other auxiliary materials such as nitrogen-hydrogen mixtures and powder or ceramic weld pool supports (backings) should as far as possible be metallurgically neutral and have no effect on the characteristics of the weld. Where such an effect cannot be ruled out (e.g. with powder supports which deplete or add to the alloying constituents), the materials shall be

included in the scope of the relevant approval or repeat tests, or shall be tested as part of the (preliminary) welding procedure tests; see Section 4, A.2 and B.3.2.

**6.6** Welding consumables - where appropriate in conjunction with the corresponding auxiliary materials - must in all positions and even at the limit values of the welding current display a satisfactory and constant welding performance without excessive spatter. The coating of covered electrodes shall not flake off during welding, nor may coated wire electrodes burst open. Should the arc be accidentally interrupted during welding, the slag shall not impede the speedy restoration of the arc. Cooled slag shall be capable of being removed from the weld without undue difficulty. The external characteristics of the weld and its internal features (as revealed by radiography) must meet the subsequent requirements of fabrication (see Section 10, G).

## 7. Performance of Approval Tests

**7.1** Unless otherwise stated below, approval tests shall be conducted in accordance with Section 1, F. The conditions under which the specimen welds are made (welding parameters, number of runs, weld build-up, etc.) must conform to the manufacturer's recommendations and to normal welding practice and be placed on record. Covered electrodes shall be consumed down to a residual length of approx. 50 mm. The heat input (energy input per unit length of weld (E) ) applied during welding shall be determined by the following formula and shall also be placed on record:

$$E = \frac{U [\text{Volts}] \times I [\text{Amps}] \times \text{welding time} [\text{min}] \times 6 \left[ \frac{\text{kJ}}{\text{mm}} \right]}{\text{length of seam} [\text{mm}] \times 100}$$

**7.2** The base materials used for approval tests shall be of the chemical composition and strength category for which the welding consumables and auxiliary materials are to be approved. For an approval covering only normal-strength hull structural steels (quality grades 1, 2 or 3), a normal-strength hull structural steel or, failing this, a comparable structural steel possessing the same minimum tensile strength (400 N/mm<sup>2</sup>) shall be used. For approvals covering higher-strength hull structural steels (quality grades 1Y, 2Y, 3Y or 4Y), a higher-strength hull structural steel or a comparable structural steel (e.g. S 355 (St 52-3) having

a tensile strength of at least 490 N/mm<sup>2</sup> shall be used.

For approvals covering the quality grades 2Y40, 3Y40 or 4Y40, a hull structural steel or a comparable structural steel with a tensile strength of at least 510 N/mm<sup>2</sup> shall be used. For testing the pure weld metal, normal-strength hull structural steels or comparable structural steels may generally be used. For welding consumables with a very divergent chemical composition, the side walls of the test piece may, if necessary, be provided with a buffer (e.g. in the case of stainless steels) and a backing strip of the same composition as the plate may be used.

**7.3** Where welding consumables and auxiliary materials are to be approved for welding with both direct and alternating current, this must be specified and the test shall be conducted with alternating current. In special cases, verification of the welding characteristics using direct current may be demanded as an alternative or in addition (e.g. for covered electrodes used for gravity welding with direct and alternating current, and for certain welding processes).

**7.4** Post-weld heat treatment of the test pieces or specimens is not allowed where products are to be approved for the untreated condition alone; see also the preliminary remarks relating to B. Excepted from this rule is the heat treatment of tensile specimens to reduce their hydrogen content as described below in relation to the various welding consumables and auxiliary materials. Where welding consumables and auxiliary materials are also to be approved for the heat-treated condition, the prescribed additional test pieces must be prepared (H.1.3) and heat-treated accordingly.

Follow-up heat treatment of the specimens once they have been removed from the test pieces is not allowed.

**7.5** In special cases, further tests (e.g. hardness measurements, examination of macro- or micrographic specimens to check weld penetration and structural characteristics, etc.) or the testing of notched bar impact test specimens at temperatures lower than those specified may be stipulated in addition to the test pieces and specimens called for in the following. In the case of welding consumables and auxiliary materials for austenitic stainless steels, proof is required of resistance to intergranular corrosion and for solid austenitic steels resistance to hot cracks must also be demonstrated.

**7.6** Should individual test results fail to meet the requirements, a double quantity of test pieces and specimens of the same kind shall be freshly prepared and subjected to testing. Base materials, welding consumables and auxiliary materials originating from the same delivery as those used for the first test shall be used for this purpose. Should the specimens again fail, approval will not be granted until the reasons have been clarified and a complete new test has been conducted (see also 5.3). For the repetition of notched bar impact tests, see the following provisions relating to the various welding consumables and auxiliary materials.

**7.7.** TL may request, in a particular case, additional tests or requirements as may be considered necessary.

## **8. Mechanical testing procedure**

Unless specified otherwise, mechanical testing procedure of welding consumables defined in this section shall comply with this item.

### **8.1 Test specimens**

#### **8.1.1 Specimens dimensions**

Deposited metal and butt weld tensile, butt weld bend and Charpy V-notch impact test specimens are to be machined to the dimensions given in Chapter 2 Material Section 2.

#### **8.1.2 Specimens location and preparation**

##### **8.1.2.1 Deposited metal tensile**

The longitudinal axis must coincide with the centre of the weld and:

- the mid thickness of the weld in the deposited metal test assemblies;
- the mid thickness of the 2nd run in the two-run welded test assemblies.

The specimens may be heated to a temperature not exceeding 250°C for a period not exceeding 16 hours for hydrogen removal prior to testing.

##### **8.1.2.2 Butt weld tensile**

The upper and lower surfaces of the weld are to be filed, ground or machined flush with the surface of the plate.

##### **8.1.2.3 Butt weld bend**

The upper and lower surfaces of the weld are to be filed, ground or machined flush with the surface of the plate and the sharp corners of the specimens rounded to a radius not exceeding 2 mm.

##### **8.1.2.4 Charpy V-notch impact**

The test specimens shall be cut with their longitudinal axes transverse to the weld length and:

- at mid thickness of the weld in the deposit metal and butt weld test assemblies with multirun technique;
- on the 2nd run side, 2 mm maximum below the surface in the two-run welded test assemblies;
- 2 mm maximum below one surface in the electroslag or electrogas welded test assemblies.

The notch shall be cut in the face of the test piece perpendicular to the surface of the plate and shall be positioned in the centre of the weld and, for electroslag and electrogas welded test assemblies, also at 2 mm from the fusion line in the deposited metal.

## **8.2 Testing procedures**

### **8.2.1 Tensile**

Tensile tests are to be carried out on an approved tensile testing machine.

On deposited metal test specimens, the values of yield stress, tensile strength and elongation are to be recorded. On butt weld specimens, the values of tensile strength are to be recorded together with the position of fracture.

### 8.2.2 Bend

The test specimens are to be capable of withstanding, without fracture or crack, being bent through an angle of 120° over a former having a diameter three times the thickness of the specimen.

However, superficial cracks of less than 3 mm long on the outer surface should not be taken into consideration. For each set of bend tests one specimen is to be tested with the face of the weld in tension and the other with the root of the weld in tension except in the electroslag or electrogas welded test assemblies, where side bend tests are carried out in lieu of face and root bend tests.

### 8.2.3 Charpy V-notch impact

Impact tests are to be carried out on a Charpy impact machine of an approved type.

A set of three test specimens is to be prepared and tested. The average absorbed energy value is to comply with the requirements of subsequent sections. One individual value may be less than the required average value provided that it is not less than 70% of this value. The test temperature for Grades 2, 2Y, 2Y 40, 3, 3Y, 3Y 40, 4Y and 4Y 40 test pieces is to be controlled to within  $\pm 2^\circ\text{C}$  of the prescribed temperature.

## 8.3 Re-test procedures

### 8.3.1 Tensile and bend

Where the result of a tensile or bend test does not comply with the requirements, duplicate test specimens of the same type are to be prepared and satisfactorily tested. Where insufficient original welded assembly is available, a new assembly is to be prepared using welding consumables from the same batch. If the new assembly is made with the same procedure (particularly the number of runs) as the original assembly, only the duplicate re-test specimens needs to be prepared and tested. Otherwise, all test specimens should be prepared as for re-testing.

### 8.3.2 Charpy V-notch impact

Re-test requirements for Charpy impact tests are to be in accordance with Chapter 2 Material Section 2. Further re-tests may be made at the Surveyor's discretion, but these must be made on a new welded assembly and must include all tests required for the original assembly, even those which were previously satisfactory.

## B. Covered Electrodes for Manual Metal-Arc Welding of Hull Structural Steels

### *Preliminary remarks:*

*In normal shipbuilding practice, components are in general not subjected to post-weld heat treatment (e.g. annealing to relieve stresses). Consequently, the welding consumables and auxiliary materials to be used for ship constructions are generally tested and approved for the untreated, i.e. as-welded, condition.*

*Should post-weld heat treatment nevertheless be intended or required in special cases, only welding consumables and auxiliary materials with properties and quality grades which have been proved to be adequate in the respective heat-treated condition shall be used. The nature and scope of the necessary verifications shall be determined on a case-by-case basis.*

*In the case of welding consumables for hull structural steels, the test temperature for the base material in question (see Section 12, Table 12.1 as well as the Chapter 1, Hull, Section 2) may be assumed to be the minimum load temperature (design temperature). A temperature of 300°C is generally considered to be the maximum load temperature.*

## 1. General

**1.1** The following provisions apply to covered electrodes for manual metal-arc welding of hull structural steels, including the corresponding grades of steel forgings and castings, and of comparable structural steels. Covered electrodes for semi-mechanized gravity welding and spring-loaded welding processes are treated in the same way as those for manual metal-arc welding.

**1.2** Depending on the results of the Charpy V-notch impact tests, electrodes are divided into the following grades:

- For normal strength steel: Grades 1, 2 and 3.

- For higher strength steel with minimum yield strength up to 355 N/mm<sup>2</sup>: Grades 2Y and 3Y and 4Y (Grade 1Y not applicable for manual welding).
- For higher strength steels with minimum yield strength up to 390 N/mm<sup>2</sup>: Grades 2Y 40, 3Y40, and 4Y 40. In special cases, e.g. when the electrodes are also used for steels tough at subzero temperatures, approval may be granted with a higher quality grade, as with welding consumables and auxiliary materials for high-strength (quenched and tempered) structural steels (see F. and Table 5.14). Regarding added symbols, inclusions and exclusions, see A.4.1.

### 1.3 Hydrogen Marks

If the electrodes are in compliance with the requirements of the hydrogen test given in 4.5 hereafter, a suffix H15, H10 or H5 will be added to the Grade mark.

## 2. Testing the Weld Metal (Deposited Metal Tests)

**2.1** For testing the deposited weld metal, two test pieces of the type shown in Figure 5.1 are to be prepared in the downhand PA(d) welding position, one with 4 mm diameter electrodes and the other with the largest size manufactured. If an electrode is available in one diameter only, one test assembly is sufficient. Any grade of ship structural steel may be used for the preparation of these test assemblies

In accordance with the covered electrodes used and normal welding practice, the weld metal shall be laid down in layers comprising single or multiple runs. The layers shall be welded in alternate directions, and the individual runs shall be 2 - 4 mm thick. Prior to the welding of each new layer, the test piece shall be cooled in still air to 250°C or below, but on no account to below 100°C. The temperature shall be measured at the surface of the centre of the weld.

**2.2** The chemical composition of the deposited weld metal shall be determined by the manufacturer using recognized methods of analysis and shall be certified by him. The analysis shall encompass all the important alloying constituents and impurities (e.g. phosphorus and sulphur). The results of the analysis shall not exceed the limits specified in the standards. In special cases, narrower tolerances for the constituents may be stipulated.

**2.3** Following the recommended radiographic examination, one round tensile test specimen and three ISO V-notch impact test specimens conforming to Figure 5.1 shall be machined from each weld metal test piece. The longitudinal axis of the round tensile specimen shall be located in the centre of the weld at the mid-point of the plate thickness. Tests are to be performed according to A.8 Mechanical Testing Procedures. The upper lateral surface of the impact test specimens shall lie 5 mm below the surface of the plate with the notch also located in the centre of the weld.

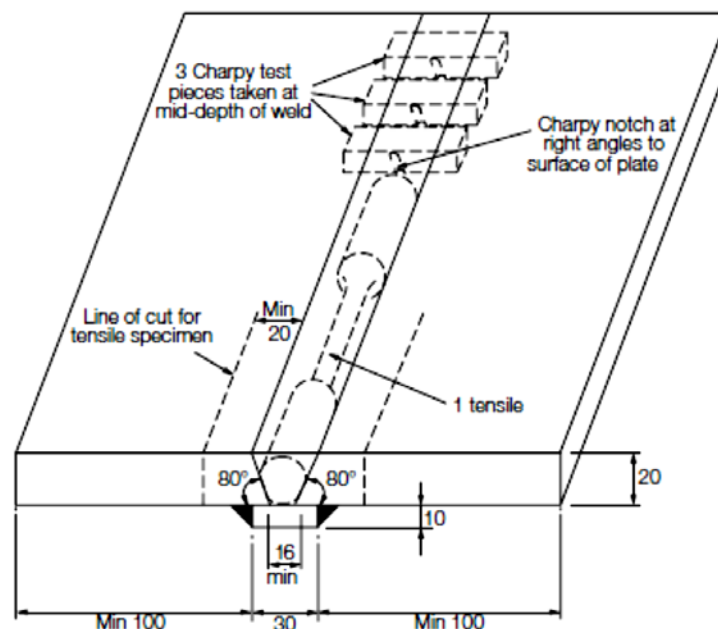

All dimensions in mm unless otherwise indicated

Figure 5.1 Weld metal test piece

**2.4** The mechanical properties of the weld metal must meet the requirements stated in Table 5.3. If the tensile strength exceeds the upper limit, approval of the electrode will be granted only after careful consideration of its other technological properties and the chemical analysis of the weld metal. The mean value for the

notch impact energy must meet the requirements of the following sections; an individual value may be below the required mean value but not less than 70% of this value.

**2.5** For the carrying out of retests, see A.7.6.

**Table 5.3 Required properties of the weld metal**

Quality grade (1)	Minimum yield strength [N/mm <sup>2</sup> ]	Tensile strength [N/mm <sup>2</sup> ]	Minimum elongation (L <sub>o</sub> =5·d <sub>o</sub> ) [%]	Minimum notch impact energy [J] (2)	Test temperature [°C]
1	305	400 - 560	22	47 (33)	+ 20
2					0
3					- 20
2Y	375	490 - 660	22	47 (33)	0
3Y					- 20
4Y					- 40
2Y40	400	510 (3) - 690	22	47 (33)	0
3Y40					- 20
4Y40					- 40
<p><b>(1)</b> For possible higher quality grades, see 1.2.</p> <p><b>(2)</b> Mean value of three specimens; ( ) for minimum individual values; for this and retests, see 2.4 and 2.5.</p> <p><b>(3)</b> A tensile strength of 500 [N/mm<sup>2</sup>] is acceptable if adequate values are achieved in the welded joint.</p>					

**2.6** Further repeat tests require the consent of TL in each individual case; see also A.7.6. Such tests, however, shall without exception comprise the welding of a new test piece and the testing of all the specimens originally required, even if some of them gave satisfactory results in the first test.

### 3. Testing on Welded Joints (Butt weld tests)

#### 3.1 Preparation of butt weld test assemblies

Butt-welded test pieces in accordance with Figure 5.2 shall be welded in the each welding positions (downhand, horizontal-vertical, vertical-upward, vertical-downward and overhead) and with the electrode diameters shown in Table 5.4 according to the welding positions covered by the approval application (see A.4.9 and Table 5.1), except that electrodes satisfying the requirements for downhand

and vertical-upward positions will be considered as also complying with the requirements for the horizontal-vertical position subject to the agreement of TL.

Where covered electrodes are to be approved only for fillet welding (e.g. for gravity welding), fillet-welded test pieces as shown in Figure 5.3 instead of butt-welded test pieces shall be welded and subjected to test. In special cases, TL may call for fillet-welded as well as butt-welded test pieces, e.g. for vertical-down welding.

For the preparation of the test assemblies one of the steel grades as listed below for the individual electrode grades shall be used:

- Grade 1 electrodes : A
- Grade 2 electrodes : A, B, D
- Grade 3 electrodes : A, B, D, E

- Grade 2Y electrodes : A32, A36, D32, D36
- Grade 3Y electrodes : A32, A36, D32, D36, E32, E36.
- Grade 4Y electrodes : A32, A36, D32, D36, E32, E36, F32, F36
- Grade 2Y40 electrodes : A40, D40
- Grade 3Y 40 electrodes : A40, D40, E40
- Grade 4Y 40 electrodes : A40, D40, E40, F40

Where higher strength steel with minimum yield strength  $315 \text{ N/mm}^2$  is used for grade 2Y, 3Y and 4Y electrodes, the actual tensile strength of the steel is to be not less than  $490 \text{ N/mm}^2$ .

The chemical composition including the content of grain refining elements is to be reported.

### 3.2 Sequence of welding

**3.2.1** The following welding procedure is to be adopted in making test assemblies (Table 5.4) :

**Downhand (a):** The first run with 4 mm diameter electrode. Remaining runs (except the last two layers) with 5 mm diameter electrodes or above according to the normal welding practice with the electrodes. The runs of the last two layers with the largest diameter of electrode manufactured.

**Downhand (b):** (Where a second downhand test is required). First run with 4 mm diameter electrode. Next run with an electrode of intermediate diameter of 5 mm or 6 mm, and the remaining runs with the largest diameter of electrode manufactured.

**Horizontal-vertical:** First run with 4 mm or 5 mm diameter electrode. Subsequent runs with 5 mm diameter electrodes.

**Vertical-upward and overhead:** First run with 3.25 mm diameter electrode. Remaining runs with 4 mm diameter electrodes or possibly with 5 mm if this is recommended by the manufacturer for the positions concerned.

**Vertical-downward:** If the electrode tested is intended for vertical welding in the downward direction, this technique is to be adopted for the preparation of the test assembly using electrode diameters as recommended by the manufacturer.

For all assemblies the back sealing runs are to be made with 4 mm diameter electrodes in the welding position appropriate to each test sample, after cutting out the root run to clean metal. For electrodes suitable for downhand welding only, the test assemblies may be turned over to carry out the back sealing run.

Normal welding practice is to be used, and between each run the assembly is to be left in still air until it has cooled to less than  $250^\circ\text{C}$  but not below  $100^\circ\text{C}$ , the temperature being taken in the centre of the weld, on the surface of the seam. After welding, the test assemblies are not to be subjected to any heat treatment.

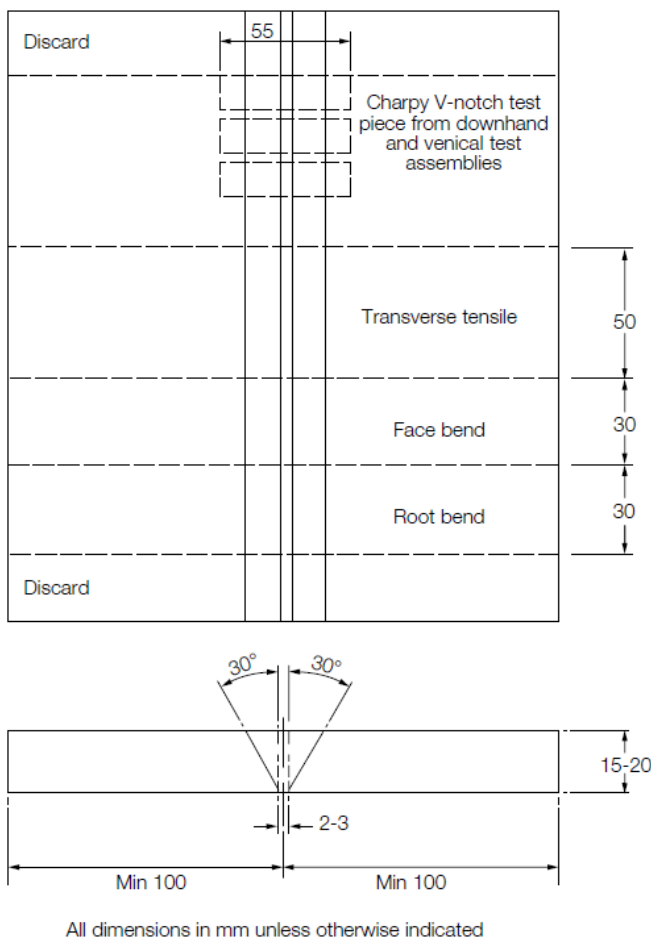

**Figure 5.2 Butt-weld test piece**

Table 5.4 Butt-weld test pieces, welding positions and electrode diameters

Position(s) applied for approval	Butt-weld test pieces required . . .				
	. . . in position(s)		. . . with electrode diameter(s) (1)		
	No.	Position	Root pass	Fill and cover passes	Back pass
All positions incl. vertical-down (1) (3)	1	PA (d)	4	5 to 8 (2)	4
	1	PF (v-u)	3,25	4 or 5	4
	1	PE (o)	3,25	4 or 5	4
	1	PG (v-d)	acc. to manufacturer's instructions		
All positions except vertical-down (2) (3)	1	PA (d)	4	5 to 8 (2)	4
	1	PF (v-u)	3,25	4 to 5	4
	1	PE (o)	3,25	4 to 5	4
Downhand positions and vertical-up (3) (3)	1	PA (d)	4	5 to 8 (2)	4
	1	PF (v-u)	3,25	4 to 5	4
Downhand positions Only (4)	1	PA (d)	4	5 to 8 (2)	4
	1	PA (d)	4	5 to 8 (4)	4
Horizontal-vertical PC (h-v) position only	1	PC (h-v)	4 or 5	5	4
Other individual Positions (X)	1	(X)	as specified above		

(1) Electrode diameters in [mm].  
(2) Filler passes with 5 or 6 mm size; last two runs including the cover pass with the largest diameter electrodes produced, up to a maximum of 8 mm.  
(3) Includes the horizontal-vertical PC (h-v) position.  
(4) Second pass with 5 or 6 mm size; all other filler and cover passes to be made with the largest diameter electrodes produced, up to a maximum of 8 mm.

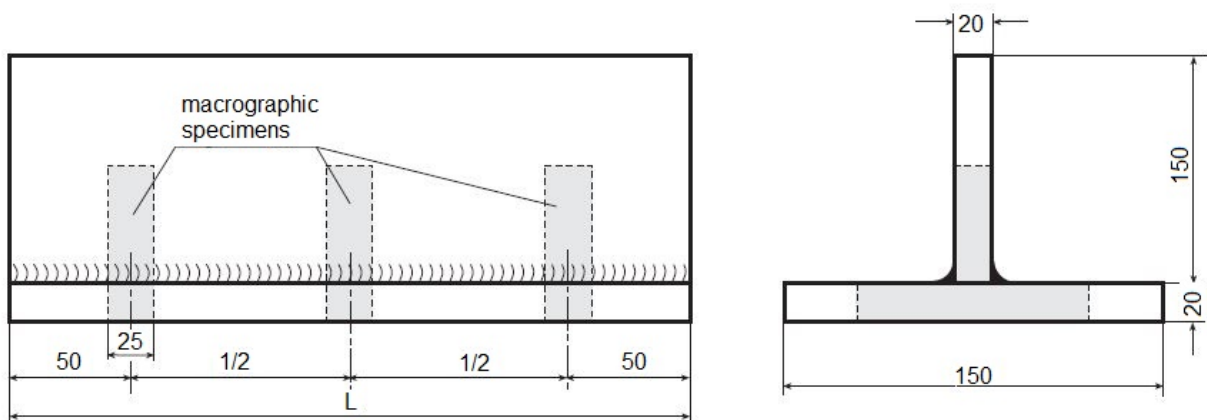

Figure 5.3 Fillet-weld test piece



Table 5.5 Requirements for butt weld test (covered manual electrodes)

Quality grade	Tensile strength (transverse test) N/mm <sup>2</sup>	Charpy V-notch impact tests		
		Test Temperature °C	Average energy - J minimum	
			Downhand, horizontal-vertical, overhead	Vertical (upward and downward)
1	400	20	47	34
2		0	47	34
3		-20	47	34
2Y	490	0	47	34
3Y		-20	47	34
4Y		-40	47	34
2Y 40	510	0	47	39
3Y 40		-20	47	39
4Y 40		-40	47	39

**3.2.2** For the base materials to be used, see A.7.2; their chemical composition is to be recorded.

Before the backing pass is laid down, the root is to be grooved - wherever possible by machining - from the rear.

**3.2.3** The position of the fracture shall be recorded. Bend test specimens displaying incipient cracks shall be broken open for assessment of the fracture. TL may stipulate that the bend tests or supplementary bend tests be performed within a set time limit in order to ascertain possible effects of hydrogen.

### 3.3 Radiographic examination

It is recommended that the welded assemblies be subjected to a radiographic examination to ascertain if there are any defects in the weld prior to the preparation of test specimens.

### 3.4 Execution of tests

The test specimens as shown in Figure 5.2 are to be prepared from each test assembly. Tests are to be performed according to A.8 Mechanical Testing Procedures.

### 3.5 Result of tests and requirements

The results of all tensile and impact tests are to comply

with the requirements of Table 5.5 as appropriate.

The position of fracture in the transverse tensile test is to be reported. The bend test specimens can be considered as complying with the requirements if, after bending, no crack or defect having any dimensions exceeding 3 mm can be seen on the outer surface of the test specimen.

## 4. Hot-Cracking Test

**4.1** Where TL requires that a hotcracking test be performed, two plates shall for that purpose be welded together in the manner shown in Figure 5.4. The end face of the web plate must be cut straight and at right angles and must fit snugly against the flat upper surface of the bottom plate. Any unevenness is to be removed. The base plate shall be stiffened by three transverse web plates.

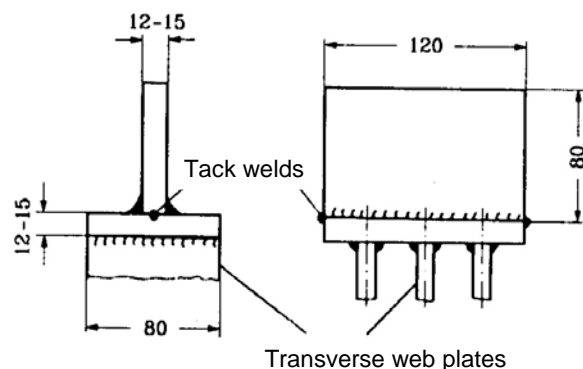

Figure 5.4 Test piece for hot cracking

**4.2** The first fillet weld is to be laid down in a single pass in the downhand PA (d) position. During this operation, the current must be at the upper limit of the range prescribed for the electrode. The second fillet weld on the opposite side shall be laid down immediately after the first, also in the downhand PA (d) position and starting at the end of the test piece where the first fillet weld terminated. Both fillet welds are to be laid down at a uniform speed without weaving of the electrode.

**4.3** For the welding of the complete length of each fillet weld (120 mm), the electrode lengths indicated in Table 5.6 are to be molten off.

After welding, the slag shall at once be removed from the fillet welds.

**4.4** Half an hour after welding, at the earliest, i.e. when the test piece has cooled completely through its entire thickness, the fillet welds are to be examined for cracks with a magnifying glass or by a crack-detecting technique.

The first fillet weld shall then be removed by machining and the second fillet weld shall be fractured by collapsing the plates (with the root in tension). The fractured seam shall then be examined for hot cracks. When subjected to testing for hot cracks, the fillet welds may not reveal any superficial or internal cracks of any kind. Only end crater cracks may be tolerated.

**Table 5.6 Molten-off lengths of electrodes**

Electrode core wire diameter [mm]	Molten-off lengths	
	1 <sup>st</sup> fillet weld [mm]	2 <sup>nd</sup> fillet weld [mm]
4	200	150
5	150	100
6	100	75

## 5. Hydrogen Test

**5.1** The hydrogen test to determine the diffusible hydrogen content of the weld metal should, where possible, be conducted according to the mercury method prescribed in DIN 8572 Part 1 and ISO standard 3690 or, with TL's consent, according to other

comparable methods. For an interim period and with TL's consent, the glycerin method described in 5.3 may continue to be used as an alternative for the added symbols H15(H) and H10(HH). Depending on the added symbols H15(H), H10(HH) or H5(HHH) to be appended to the quality grade specified in the approval (see A.4.1), the hydrogen content of the weld metal shall not exceed the limits indicated in Table 5.7.

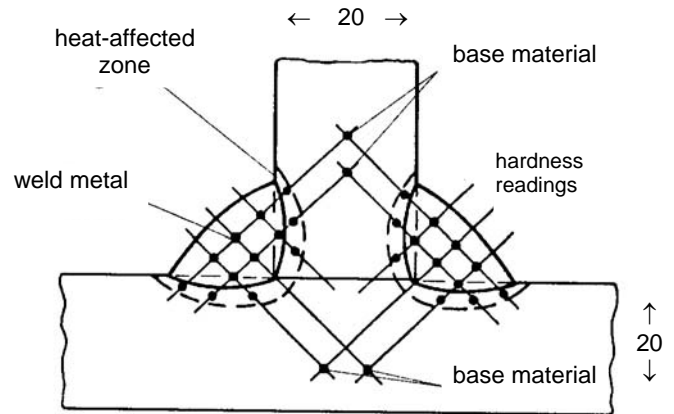

**Figure 5.5 Hardness measurements**

**5.2** The mercury method or thermal conductivity detector method according to standard ISO 3690 is to be used. Four weld assemblies are to be prepared. The temperature of the specimens and minimum holding time are to be complied with following, according to the measuring method respectively:

Measuring method		Test temperature [°C]	Minimum holding time [h]
Thermal Conductivity Detector Method (*)	Gas Chromatography	45	72
		150	6

(\*) The use of hot carrier gas extraction method may be considered subject to verification of the testing procedure to confirm that collection and measurement of the hydrogen occurs continuously until all of the diffusible hydrogen is quantified.

**5.3** Where the glycerin method of testing for hydrogen is used, the following procedure shall be adopted:

**5.3.1** Four sample bars of normalized steel (1) measuring 125 x 25 x 12 mm. shall be thoroughly cleaned and weighed to the nearest 0,1 g. A single bead of weld, approximately 100 mm. long, is to be laid down on one of the 125 x 25 mm. faces of each sample bar, on each occasion using a new 4 mm. diameter covered electrode. 120 to 150 mm. of the electrode length shall be consumed in the process.

**5.3.2** The welding operation shall be performed with a current of approximately 150 A and the shortest possible arc. Where the welding process is mechanized, the electrode diameter and the amperage shall be so chosen that the thermal input corresponds to that of manual arc welding. Prior to welding, the consumables may be baked in the normal manner prescribed by the manufacturer.

**5.3.3** The electrodes, prior to welding, can be submitted to the normal drying process recommended by the manufacturer. Within 30 seconds of the completion of the welding of each specimen the slag is to be removed and the specimen quenched in water at approximately 20°C.

**5.3.4** During the test, the temperature of the glycerin is to be held at 45°C. All four sample bars are to be left immersed in the glycerin for 48 hours, after which they are to be taken out and cleaned with water and alcohol. After drying, the sample bars shall again be weighed to the nearest 0,1 g. to determine the quantity of deposited weld metal.

**5.3.5** Results to be obtained

The volume of gas collected in the test vessel is to be measured to the nearest 0,05 cm<sup>3</sup> and corrected for a temperature of 0 °C and a pressure of 760 mm. of mercury.

The individual and average diffusible hydrogen contents of the four specimens are to be reported, and the average value in cm<sup>3</sup> per 100 grams is not to exceed the values stated :in Table 5.7.

**(1)** *Wherever possible, the steel should not contain more than the following components: 0,15% C, 0,10% Si, 1,0% Mn, 0,03 % P, 0,03 % S.*

**Table 5.7 Permissible hydrogen content of weld metal**

Mark	Diffusible Hydrogen contents	Measuring method
H 15	15 (1)	Mercury Method
H 10	10 (2)	Thermal Conductivity Detector Method Glycerine Method Mercury Method
H 5	5	Thermal Conductivity Detector Method
<p><b>(1)</b> <i>10 cm<sup>3</sup> per 100 grams where the glycerine method is used.</i></p> <p><b>(2)</b> <i>5 cm<sup>3</sup> per 100 grams where the glycerine method is used.</i></p>		

*Note: The glycerine method is not to be used for the welding consumables with H 5 mark.*

## 6. Covered electrodes for manual fillet welding

Where an electrode is submitted only to approval for fillet welding and to which the butt weld test provided in B.3 is not considered applicable, the first approval tests are to consist of the fillet weld tests given in B.6.1, and deposited metal tests similar to those indicated in B.2.

Where an electrode is submitted to approval for both butt and fillet welding, the first approval tests may, at the discretion of TL, include one fillet weld test as detailed hereunder and welded in the horizontal-vertical position.

### 6.1 Fillet weld test assemblies

When the electrode is proposed only for fillet welding, fillet weld assemblies as shown in Figure 5.3, are to be prepared for each welding position (horizontal-vertical, vertical upwards, vertical downwards or overhead) for which the electrode is recommended by the manufacturer. The length of the test assemblies L is to be sufficient to allow at least the deposition of the entire length of the electrode being tested.

The grade of steel used for the test assemblies is to be as detailed in B.3.1.

The first side is to be welded using the maximum size of electrode manufactured and the second side is to be

welded using the minimum size of electrode manufactured and recommended for fillet welding. The fillet size will in general be determined by the electrode size and the welding current employed during testing.

The length "L" of the test piece shall be such as to permit the melt-off of at least one complete electrode length - namely, the longest produced - with a throat thickness appropriate to the electrode diameter.

## 6.2 Tests on fillet weld assemblies

### 6.2.1 Macrographs

Each test assembly is to be sectioned to form three macro-sections each about 25 mm thick. They are to be examined for root penetration, satisfactory profile, freedom from cracking and reasonable freedom from porosities and slag inclusions.

### 6.2.2 Hardness

At the discretion of TL, the hardness of the weld, of the heat affected zone (HAZ) and of parent metal may be

determined, and reported for information (see Figure 5.5).

Following visual inspection and assessment, the fillet-weld test pieces shall be sectioned in the manner shown in Figure 5.3, and the macrographic specimens marked with "M" shall be prepared for evaluation of the weld penetration and measurement of the hardness in accordance with Figure 5.5. Wherever possible, Vickers hardness measurements (EN ISO 6507-1, HV 10) should be performed.

The hardness of the weld metal obtained with welding consumables and auxiliary materials for higher-strength hull structural steels with minimum yield strength up to 355 N/mm<sup>2</sup> (added symbol Y) shall not be less than 150 HV and the corresponding hardness for higher-strength hull structural steels with a minimum yield strength of 390 N/mm<sup>2</sup> (added symbol Y40) shall not be less than 160 HV. The test report shall also record the hardness values measured in the heat-affected zone and the base material. Equivalent values for other methods of measurement shall be agreed.

Table 5.8 Required properties of welded joints

Quality grade (1)	Tensile strength [N/mm <sup>2</sup> ]	Minimum notch impact energy [J] (2)			Minimum bending angle, mandrel diameter = 3 x thickness of specimen
		Positions		Test temperature [°C]	
		PA, PC, PE (d, h-v, o)	PF, PG (v-u, v-d)		
1	≥ 400	47 (33)	34(24)	+ 20	120° before the first incipient crack, minor pore exposures up to a maximum length of 3 mm. allowed.
2				± 0	
3				- 20	
2Y	≥ 490	47 (33)	34(24)	±0	
3Y				- 20	
4Y				- 40	
2Y40	≥ 510	47 (33)	41(29)	0	
3Y40				- 20	
4Y40				- 40	

(1) For possible higher quality grades, see 1.2.  
(2) Mean value of three specimens, ( ) minimum individual values; for this and retests, see 2.4 and 2.5.

### 6.2.3 Fracture

One of the remaining sections of the fillet weld is to have the weld on the first side gouged or machined to facilitate breaking the fillet weld, on the second side by closing the two plates together, submitting the root of the weld to tension. On the other remaining section, the weld on the second side is to be gouged or machined and the section fractured using the same procedure. The fractured surfaces are to be examined and there should be no evidence of incomplete penetration, or internal cracking and they should be reasonably free from porosity. See also Section 12, G.10.3.4.

## 7. Covered electrodes for gravity or contact welding

Where an electrode is submitted solely to approval for use in contact welding using automatic gravity or similar welding devices, deposited metal tests, fillet weld tests and, where appropriate, butt weld tests similar to those for normal manual electrodes are to be carried out using the process for which the electrode is recommended by the manufacturer.

Where a covered electrode is submitted to approval for use in contact welding using automatic gravity or similar welding devices in addition to normal manual welding, fillet weld and, where appropriate, butt weld tests, using the gravity of other contact device as recommended by the manufacturer, are to be carried out in addition to the normal approval tests.

In the case of a fillet welding electrode using automatic gravity or similar contact welding devices, the fillet welding should be carried out using the welding process recommended by the manufacturer, with the longest size of the electrode manufactured. The manufacturer's recommended current range is to be reported for each electrode size.

Where approval is requested for the welding of both normal strength and higher strength steel, the assemblies are to be prepared using higher strength steel.

## 8. Annual Repeat Tests and upgrading

8.1 Annual tests and periodical inspection of manufacturer's plant.

All establishments where approved electrodes are manufactured shall be subject to annual inspection.

The annual tests are to consist of at least the following:

### 8.1.1 Covered electrode for normal manual arc welding

Two deposited metal test assemblies are to be prepared in accordance with B.2 The mechanical properties (one tensile test, 3 Charpy-V impact tests on each assembly) are to be in accordance with Table 5.3. This also applies to electrodes which are approved only for fillet welding.

At the discretion of TL, a butt weld test to be welded in down-hand or in vertical position, can be required in lieu of the deposited metal test 4 mm electrodes. Three Charpy V-notch impact test specimens are to be taken from the butt weld assembly.

For Mark H 10 and Mark H 5 covered electrodes, a hydrogen test following 4.5 can also be required for each annual test at the discretion of TL.

### 8.1.2 Covered electrodes for gravity or contact welding

Where an electrode is approved solely for gravity or contact welding, the annual test is to consist of one deposited metal test assembly using the gravity or other contact device as recommended by the manufacturer. If this electrode is approved also for normal manual arc welding the annual test is to be performed according to 8.1.1.

## 8.2 Upgrading and uprating of electrodes

8.2.1 Upgrading and uprating will be considered only at the manufacturer's request, preferably at the time of annual testing. Generally, for this purpose, tests on butt-weld assemblies will be required in addition to the normal reapproval tests.

8.2.2 Upgrading refers to notch toughness and consequently, only Charpy V impact tests are required from the respective butt-weld assemblies as required by B.3.2.1 (downhand, horizontal vertical, vertical up or/and down, overhead, as applicable), and have to be

performed at the upgraded temperature.

These butt-weld tests are to be made in addition to the normal requirements for annual deposited metal tests (which have, of course, to take into consideration the upgraded temperature for Charpy V specimens).

**8.2.3** Upgrading refers to the extension of approval in order to cover the welding of higher strength steels; of course, welding of normal strength steels continue to be covered by the extended approval, as stated in A. 4.1.

For this purpose all butt-weld tests are to be made again, as required in B.3.2 and using higher strength steel, as parent metal.

## C. Wires and Wire-Gas Combinations for Metal Arc Welding

### 1 General

#### 1.1 Categories

Wire-gas combinations and flux-cored or flux-coated wires (for use with or without a shielding gas) are divided into the following categories for the purposes of approval testing:

- For use in semi-automatic multirun welding.
- For use in single electrode automatic multirun welding.
- For use in single electrode automatic two-run welding.

**Note:**

*The term semi-automatic is used to describe processes in which the weld is made manually by a welder holding a gun through which the electrode wire is continuously fed.*

#### 1.2 Grades and suffixes

**1.2.1** Depending on the results of impact tests, wires and wire-gas combinations are divided into the following grades:

- For normal strength steel Grades 1, 2 and 3;

- For higher strength steels with minimum yield strength up to 355 N/mm<sup>2</sup>: Grades 1Y, 2Y, 3Y and 4Y.
- For higher strength steels with minimum yield strength up to 390 N/mm<sup>2</sup>: Grades 2Y 40, 3Y 40, and 4Y 40.

**1.2.2** A suffix "S" will be added after the grade mark to indicate approval for semi-automatic multirun welding.

**1.2.3** For wires intended for automatic welding, the suffixes "T", "M" or "TM" will be added after the grade mark to indicate approval for two-run, multirun, or both welding techniques, respectively.

**1.2.4** For wires intended for both semi-automatic and automatic welding, the suffixes will be added in combination.

### 1.3 Composition of shielding gas

**1.3.1** Where applicable, the composition of the shielding gas is to be reported. Unless otherwise agreed by TL, additional approval tests are required when a shielding gas is used other than that used for the original approval tests.

**1.3.2** The approval of a wire in combination with any particular gas can be applied or transferred to any combination of the same wire and any gas in the same numbered group as defined in Table 5.9 subject to the agreement of TL.

### 1.4 Low hydrogen approval

**1.4.1** Flux-cored or flux-coated wires which have satisfied the requirements for Grades 2, 2Y, 2Y40,3, 3Y, 3Y40, 4Y or 4Y40 may, at manufacturer's option, be submitted to the hydrogen test as detailed in 4.5. using the manufacturer's recommended welding conditions and adjusting the deposition rate to give a weight of weld deposit per sample similar to that deposited when using manual electrodes.

**1.4.2** A suffix H15, H10 or H5 will be added to the grade mark, in the same conditions as for manual arc welding electrodes (see B.5.3.5 above) to indicate compliance with the requirements of the test.

## **2. Approval for semi-automatic multirun welding**

### **2.1 General**

Approval tests for semi-automatic multirun welding are to be carried out generally in accordance with 5.B except as required by C.2, using the semi-automatic multirun technique for the preparation of all test assemblies.

### **2.2 Preparation of deposited metal assemblies**

**2.2.1** Two deposited metal test assemblies are to be prepared in the downhand position as shown in Figure 5.1, one using the smallest diameter, and the other using the largest diameter of wire intended for the welding of ship structures. Where only one diameter is manufactured, only one deposited metal assembly is to be prepared.

**2.2.2** The weld metal is to be deposited according to the practice recommended by the manufacturer, and the thickness of each layer of weld metal is to be between 2 and 6 mm.

### **2.3 Chemical analysis**

The chemical analysis of the deposited weld metal in each test assembly is to be supplied by the manufacturer, and is to include the content of all significant alloying elements.

### **2.4 Mechanical tests**

On each assembly, tests are to be made in accordance with B.2.3, and the results are to comply with the requirements of B.2.4, appropriate to the required grade.

### **2.5 Preparation of butt weld assemblies**

**2.5.1** Butt weld assemblies as shown in Figure 5.2 are to be prepared for each welding position (downhand, horizontal-vertical, vertical upwards, vertical downwards and overhead) for which the wire or wire-gas combination is recommended by the manufacturer.

**2.5.2** The downhand assembly is to be welded using, for the first run, wire of the smallest diameter to be approved and, for the remaining runs, wire of the largest diameter to be approved.

**2.5.3.** Where approval is requested only in the downhand position, an additional butt weld assembly is to be prepared in that position using wires of different diameter from those required by 2.5.2. Where only one diameter is manufactured, only one downhand butt weld assembly is to be prepared.

**2.5.4** The butt weld assemblies in positions other than downhand, are to be welded using, for the first run, wire of the smallest diameter to be approved, and, for the remaining runs, the largest diameter of wire recommended by the manufacturer for the position concerned.

### **2.6 Radiographic examination**

It is recommended that the welded assemblies are subjected to radiographic examination to ascertain if there are any defects in the welds prior to the preparation of test specimens.

**2.7** On each assembly, tests are to be made in accordance with B. 2.3, and the results are to comply with the requirements of B 2.4.

### **2.8 Fillet weld tests**

Fillet weld test assemblies are required to be made in accordance with B.6.1 and tested in accordance with B.6.2

## **3. Approval for automatic multirun welding**

### **3.1 General**

Approval tests for automatic multirun welding are to be carried out generally in accordance with D multirun approval, except as required by D.2, using the automatic multirun technique for the preparation of all test assemblies.

### **3.2 Preparation of deposited metal assembly**

One deposited metal assembly is to be prepared as

shown in Figure 5.7. Welding is to be as detailed in D.2.2.1, except that the thickness of each layer is to be not less than 3 mm.

### 3.3 Chemical analysis

The chemical analysis of the deposited weld metal in this test assembly is to be supplied by the manufacturer, and is to include the content of all significant alloying elements.

**Table 5.9 Compositional limits of designated groups of gas types and mixtures**

Symbol (1)		Components in percent volume						Typical applications	Remarks
Group	Identification No.	Oxidizing		Inert		Reducing	Unreactive		
		CO <sub>2</sub>	O <sub>2</sub>	Ar	He	H <sub>2</sub>	N <sub>2</sub>		
R	1			balance (2)		> 0 to 15		TIG, plasma arc welding, plasma arc cutting, back shielding	reducing
	2			balance (2)		>15 to 35			
I	1			100	-			MIG, TIG, plasma arc welding, back shielding	inert
	2			-	100				
	3			balance	> 0 to 95				
M1	1	> 0 to 5	-	balance (2)		> 0 to 5		MAG	slightly oxidizing
	2	> 0 to 5	-	balance (2)		-			
	3	-	> 0 to 3	balance (2)		-			
	4	> 0 to 5	> 0 to 3	balance (2)		-			
M2	1	> 5 to 25	-	balance (2)				MAG	More pronounced oxidation
	2	-	> 3 to 10	balance (2)					
	3	> 0 to 5	> 3 to 10	balance (2)					
	4	> 5 to 25	> 0 to 8	balance (2)					
M3	1	>25 to 50	-	balance (2)				MAG	More pronounced oxidation
	2	-	> 10 to 15	balance (2)					
	3	> 5 to 50	> 8 to 15	balance (2)					
c	1	100	-					MAG	More pronounced oxidation
	2	balance	> 0 to 30						
F	1						100	plasma arc cutting, back shielding	unreactive
	2					> 0 to 50	balance		reducing

(1) Where components not listed are added to one of the groups in this Table, the gas mixture is designated as a special gas mixture and carries the prefix S. Details of the S designation are given in clause 4 of ISO 14175.

(2) Argon may be replaced by up to 95 % helium. The helium content is designated by an additional identification number.



### 3.4 Mechanical tests

Tests on this assembly are to be made in accordance with D.2.2.3, and the results are to comply with the requirements of D.2.2.4.

### 3.5 Preparation of butt weld assemblies

One butt weld assembly is to be prepared in each welding position which is to be approved. Generally, this will be the downhand position only, in which case only one assembly is required. Preparation of the assembly is to be in accordance with D.2.3.1.

### 3.6 Radiographic examination

It is recommended that each assembly be subjected to a radiographic examination to ascertain any defect in the weld prior to testing.

### 3.7 Mechanical tests

Tests are to be made on each assembly in accordance with D.2.3.3 and the results are to comply with the requirements of Table 5.10c. Where more than one assembly is prepared and tested, the number of transverse tensile and bend test specimens from each assembly may be halved.

### 3.8 Discretionary approval

At the discretion of TL, wires or wire-gas combinations approved for semi-automatic multirun welding may also be approved, without additional tests, for automatic multirun welding approval.

This is generally the case when automatic multirun welding is performed in the same conditions of welding current and energy as semi automatic welding with the concerned wire-gas combination.

The only difference between the two welding processes in this case is that the welding gun is held by an automatic device instead of the welder's hand.

## 4. Approval for automatic two-run welding

### 4.1 General

Approval tests for automatic two-run welding are to be

carried out generally in accordance with the requirements of D.3, except as required by C.4, using the automatic two-run welding technique for the preparation of all test assemblies.

### 4.2 Preparation of butt weld assemblies

**4.2.1** Two butt weld test assemblies are to be prepared, generally as detailed in D.3.1 and D.3.2, using plates 12-15 mm and 20-25 mm in thickness. If approval is requested for welding plate thicker than 25 mm, one assembly is to be prepared using plates approximately 20 mm in thickness and the other using plates of the maximum thickness for which approval is requested.

**4.2.2** The plate preparation of the test assemblies is to be as shown in Figure 5.6. Small deviations in the edge preparation may be allowed, if requested by the manufacturer. For assemblies using plates over 25 mm in thickness, the edge preparation is to be reported for information. Deviations or variations will be expected to form part of the manufacturer's standard recommended procedure for this technique and thickness range.

**4.2.3** The diameters of wires used are to be in accordance with the recommendations of the manufacturer and are to be reported.

### 4.3 Radiographic examination

It is recommended that the welded assemblies be subjected to radiographic examination to ascertain any defect in the weld prior to testing, and to confirm full penetration continuously along the major part of the welded length of each assembly.

### 4.4 Mechanical tests

Tests are to be made on each assembly in accordance with D.3.2.3 to D.3.2.6 and the results are to comply with the requirements of D.2.2.4 and Table 5.10c.

### 4.5 Chemical analysis

The chemical analysis of the deposited weld metal on the second side welded, is to be reported for each assembly.

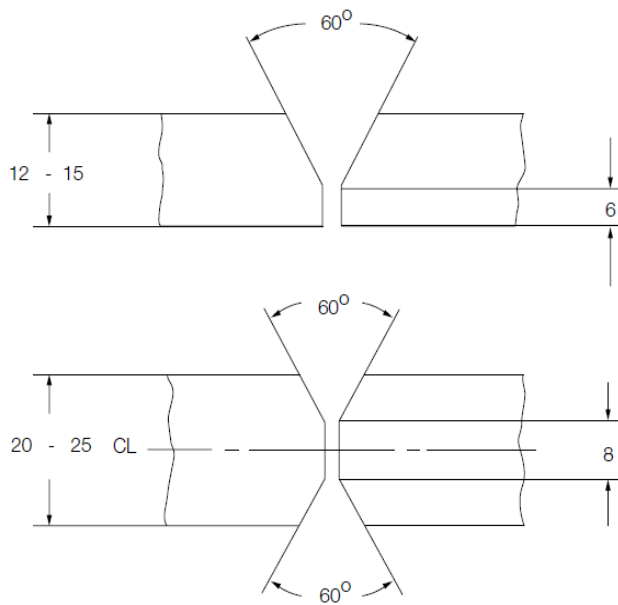

All dimensions in mm unless otherwise indicated

**Figure 5.6 Recommended edge preparation for two-run butt weld test assemblies**

## 5. Annual tests and up-grading

### 5.1 Annual tests

#### 5.1.1 Annual tests are to consist of at least:

- Wires approved for semi-automatic or both semi-automatic and automatic multirun welding : one deposited metal test assembly prepared in accordance with C.2.2 using a wire of diameter within the range approved for the semi-automatic multirun welding of ship structures.
- Wires approved for automatic multirun welding : one deposited metal test assembly prepared in accordance with C.3.2 using a wire of diameter within the range approved for automatic multirun welding of ship structures.
- Wires approved for automatic two-run welding : one butt weld test assembly prepared in accordance with C.4.2 using plates of 20-25 mm in thickness. The wire diameter used is to be reported.

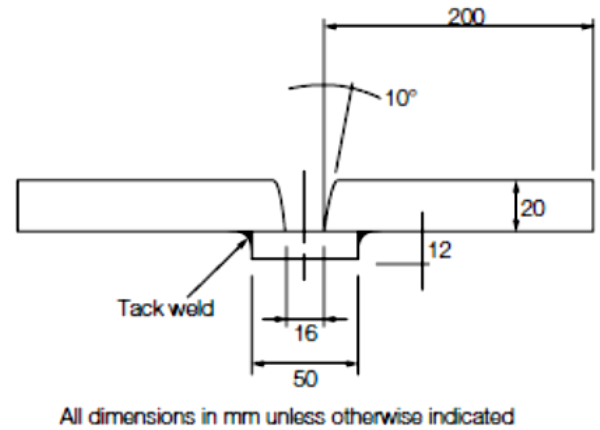

All dimensions in mm unless otherwise indicated

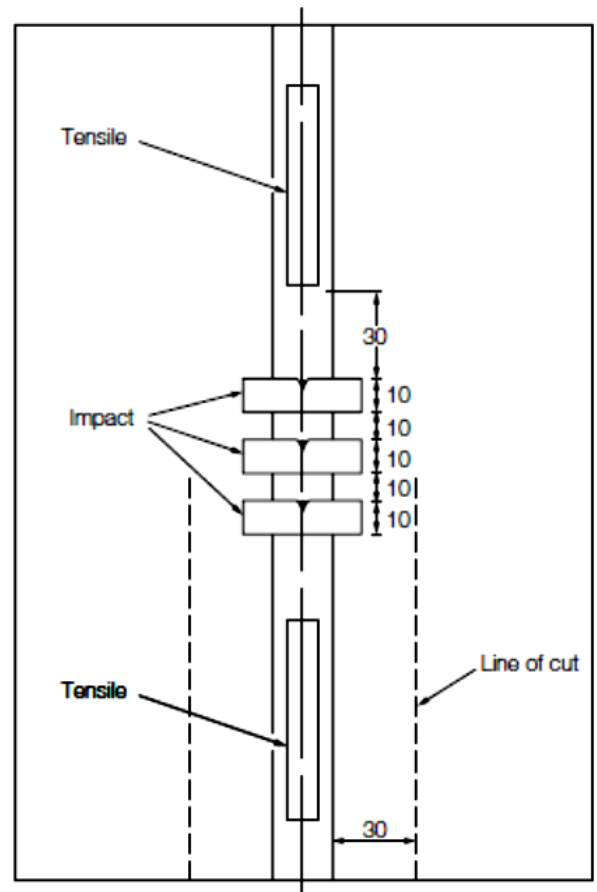

All dimensions in mm unless otherwise indicated

**Figure 5.7 Preparation of one deposited metal test assembly**

**5.1.2** The test specimens are to be prepared and tested in accordance with the requirements of this Section, except that only the following tests are required:

- For deposited metal assemblies (semi-automatic and automatic multirun) : one tensile and three impact tests.

- For butt weld assemblies (automatic two-run) : one transverse tensile, two bend and three impact tests. One longitudinal tensile test is also required where the wire is approved solely for automatic two-run welding.

**Note:**

At the discretion of **TL**, hydrogen test can be carried out following B.5.

## 5.2 Up-grading and up-rating

**5.2.1** Up-grading of flux cored wires and wire-gas combinations in connection with the impact properties will be considered as detailed in B.8.2.2

**5.2.2** Up-rating of flux cored wires and wire-gas combinations with the tensile properties will be considered as detailed in B.8.2.3

## D. Wire flux combinations for submerged arc welding

### 1. General

#### 1.1 Categories

Wire flux combinations for single electrode submerged arc automatic welding are divided into the following two categories:

- For use with the multi-run technique
- For use with the two run technique

Where particular wire-flux combinations are intended for welding with both techniques, tests are to be carried out for each technique.

#### 1.2 Grades

Depending on the results of impact tests, wire-flux combinations are divided into the following grades:

- For normal strength steel: Grades 1, 2 or 3

- For higher strength steels with minimum yield strength up to 355 N/mm<sup>2</sup>: Grades 1Y, 2Y, 3Y or 4Y.

- for higher strength steels with minimum yield strength up to 390 N/mm<sup>2</sup>: Grades 2Y 40, 3Y 40 or 4Y 40.

The suffixes T, M or TM will be added after the grade mark to indicate approval for the two-run technique, multi-run technique or both techniques, respectively.

## 1.3 Multiple electrode submerged arc welding

Wire-flux combinations for multiple electrode submerged arc welding will be subject to separate approval tests. They are to be carried out generally in accordance with the requirements of this section.

## 1.4 Mechanical tests on assemblies

Mechanical tests on assemblies with submerged arc welding for wire/flux approval are given in Table 5.10a.

## 2. Approval tests for multi run technique

### 2.1 Grades of steel

Where approval for use with the multi run technique is requested, deposited metal and butt weld tests are to be carried out.

For deposited metal test assembly any grade of ship structural steel may be used.

For butt weld test assembly one of the grades of steel as listed below for the individual grades of wireflux combinations shall be used:

- Grade 1 wire-flux combinations : A
- Grade 2 wire-flux combinations : A, B, D
- Grade 3 wire-flux combinations : A, B, D, E
- Grade 1 Y wire-flux combinations : A32, A36
- Grade 2 Y wire-flux combinations : A32, A36, D32, D36

- Grade 3 Y wire-flux combinations : A32, A36, D32, D36, E32, E 36
- Grade 4 Y wire-flux combinations : A32, A36, D32, D36, E32, E36, F32, F 36
- Grade 2 Y 40 wire-flux combinations : A40, D 40
- Grade 3 Y 40 wire-flux combinations : A40, D 40 E 40
- Grade 4 Y 40 wire-flux combinations : A40, D 40, E40, F 40

## 2.2 Deposited metal test assembly

### 2.2.1 Preparation

One deposited metal test assembly is to be prepared as shown in Figure 5.7.

**Table 5.10a Mechanical tests on assemblies with submerged arc welding for wire / flux approval**

M (multi-run technique)		T (two-run technique)		TM (two-run and multi-run technique)			
Deposited metal assembly	Butt weld assembly	Butt weld assembly (minimum thickness)	Butt weld assembly (maximum thickness)	Deposited metal assembly	Butt Weld Assembly		
					Multi-run technique	Two-run technique	
						(Minimum thickness)	(Maximum thickness)
-	2 TT	2 TT	2 TT	-	2 TT	2 TT	2 TT
-	4 TB	2 TB	2 TB	-	4 TB	2 TB	2 TB
3CV	3 CV	3 CV	3 CV	3 CV	3 CV	3 CV	3 CV
2 LT	-	1 LT	-	1 LT	-	-	1 LT

*Symbol Definition:*  
*TT: Transverse Tensile Test on the butt weld assembly*  
*TB : Transverse Bend Test on the butt weld assembly*  
*CV : Charpy-V Impact Test in the axis of the weld*  
*LT : Longitudinal Tensile Test in the weld*

Welding is to be carried out in the downhand position, and the direction of deposition of each run is to alternate from each end of the plate. After completion of each run, the flux and welding slag is to be removed. Between each run the assembly is to be left in still air until it has cooled to less than 250 °C, but not below 100 °C, the temperature being taken in the centre of the weld, on the surface of the seam. The thickness of the layer is to be not less than the diameter of the wire nor less than 4 mm.

The weld conditions, including amperage, voltage and rate of travel speed are to be in accordance with the recommendations of the manufacturer and are to conform with normal good welding practice for multi-run welding.

### 2.2.2 Chemical analysis

At the discretion of **TL**, the chemical analysis of the deposited weld metal in this test assembly is to be supplied by the manufacturer and is to include the content of all significant alloying elements.

### 2.2.3 Execution of tests

In accordance with Table 5.10a, the test specimens as shown in Figure 5.7 are to be prepared from each test assembly. Tests are to be performed according to A.8 Mechanical Testing Procedures..

## 2.2.4 Results and requirements

The results of all tests are to comply with the requirements of Table 5.10b, as appropriate.

## 2.3 Butt Weld Test Assembly

### 2.3.1 Preparation

One butt weld test assembly is to be prepared as shown in Figure 5.8 in the downhand position by welding together two plates (20 to 25 mm thick), each not less than 150 mm in width and sufficient length to allow the cutting out of test specimens of the prescribed number and size.

The plate edges are to be prepared to form a single vee joint, the included angle between the fusion faces being 60° and the root face being 4 mm.

The welding is to be carried out by the multi-run technique and the welding conditions are to be the same as those adopted for the deposited metal test assembly.

The back sealing run is to be applied in the downhand position after cutting out the root run to clean metal.

After welding the test assembly is not to be subject to any heat treatment.

**Table 5.10b Requirements for deposited metal tests (wire-flux combinations)**

Grade	Yield stress N/mm <sup>2</sup> minimum	Tensile Strength N/mm <sup>2</sup>	Elongation on 50 mm gauge length (Lo = 5 d) % minimum	Charpy V-notch impact tests	
				Test Temperature °C	Average Energy J minimum
1	305	400 - 560	22	20	34
2				0	34
3				-20	34
1Y	375	490 - 660	22	20	34
2Y				0	34
3Y				-20	34
4Y				-40	34
2Y 40	400	510 - 690	22	0	39
3Y 40				-20	39
4Y 40				-40	39

**Table 5.10c Requirements for butt weld tests (wire-flux combinations)**

Grade	Tensile strength (transverse test) N/mm <sup>2</sup>	Charpy V-notch impact tests	
		Test temperature °C	Average energy J minimum
1	400	20	34
2		0	34
3		-20	34
1Y	490	20	34
2Y		0	34
3Y		-20	34
4Y		-40	34
2Y40	510	0	39
3Y40		-20	39
4Y40		-40	39

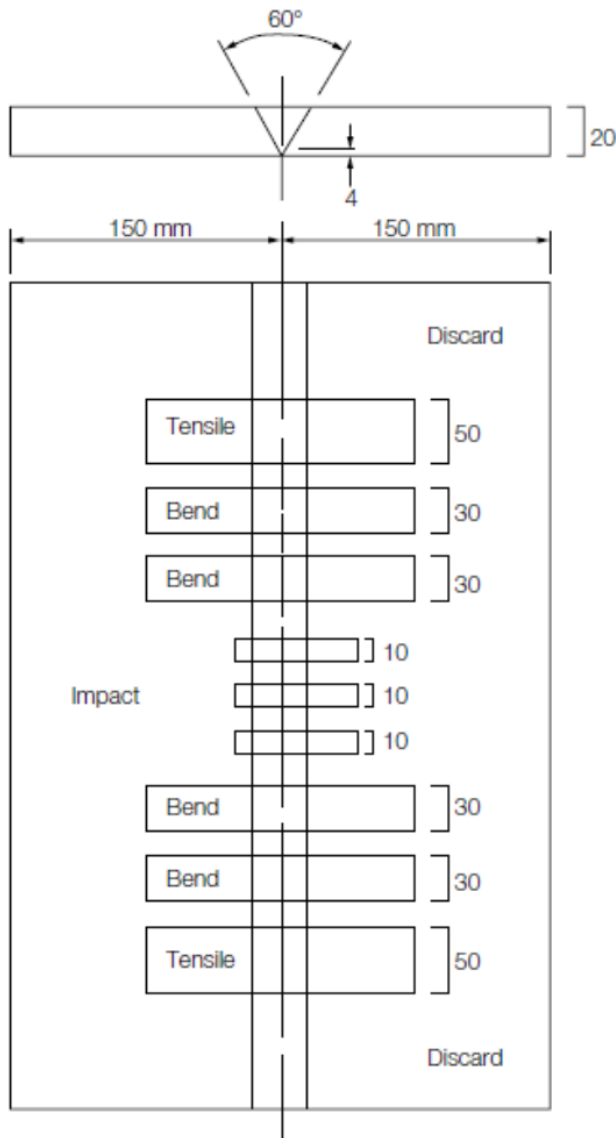

All dimensions in mm unless otherwise indicated

**Figure 5.8 Multi-run butt weld test assembly (submerged arc welding)**

### 2.3.2 Radiographic examination

It is recommended that the welded assembly be subject to a radiographic examination to ascertain if there are any defects in the weld prior to the preparation of test specimens.

### 2.3.3 Execution of tests

The test specimen to be prepared from the welded assembly are given in Table 5.10a and shown in Figure 5.8. Tests are to be performed according to A.8 Mechanical Testing Procedures..

### 2.3.4 Results of tests and requirements

The results of all tensile and impact tests are to comply with the requirements of Table 5.10c as appropriate. The position of the fracture in the transverse tensile test is to be reported.

The bend test specimens can be considered as complying with the requirements if, after bending, no crack or defect, having any dimension exceeding 3 mm can be seen on the outer surface of the test specimen.

## 3. Approval tests for two run techniques

### 3.1 Number of test assemblies

Where approval for use with the two-run technique is requested, two butt weld test assemblies are to be prepared using the following thicknesses:

- For grades 1 and 1Y: 12 to 15 mm and 20 to 25 mm
- For Grades 2, 2Y, 3, 3Y and 4Y: 20 to 25 mm and 30 to 35 mm
- For Grades 2Y 40, 3Y 40 and 4Y 40: 20 to 25 mm and 30 to 35 mm

A limitation of the approval to the medium range (up to the maximum welded plate thickness) may be agreed to by TL. Test assemblies shall then be welded using plates of 12 to 15mm and 20 to 25mm irrespective of the grade for which the approval is requested.

When a wire-flux combination is offered to approval for use with the two-run technique only, it is reminded that no deposited metal test assemblies have to be done. In this case approval tests are limited to the butt welds on two-run assemblies described in 3.2 hereafter.

Where approval is requested for welding of both normal strength and higher strength steel, two assemblies are to be prepared using higher strength steel. Two assemblies prepared using normal strength steel may also be required at the discretion of TL.

## 3.2 Butt weld test assemblies

### 3.2.1 Preparation of assemblies

The maximum diameter of wire, grades of steel plate

and edge preparation to be used are to be in accordance with Figure 5.9. Small deviations in the

edge preparation may be allowed if requested by the manufacturer. The root gap should not exceed 1 mm.

Plate thickness [mm]	Recommended preparation [mm]	Maximum diameter of wire [mm]	Grade of wire-flux combination	Grade of normal strength steel	Grade of higher strength steel
about 12 – 15		5	1	A	-
			1Y	-	A32 A36
about 20 – 25		6	1	A	-
			1Y	-	A 32, A 36
			2	A, B or D	-
			2Y	-	A 32, A 36, D 32, D 36
			2Y 40	-	A 40, D 40
			3	A, B, D or E	-
			3Y	-	A 32, A 36, D 32, D 36, E 32, E 36
			3Y 40	-	A 40, D 40, E 40
			4Y	-	A 32, A 36, D 32, D 36, E 32, E 36, F 32, F 36
			4Y 40	-	A 40, D 40, E 40, F 40
about 30 – 35		7	2	A, B or D	-
			2Y	-	A 32, A 36, D 32, D 36
			2Y 40	-	A 40, D 40
			3	A, B, D or E	-
			3Y	-	A 32, A 36, D 32, D 36, E 32, E 36
			3Y 40	-	A 40, D 40, E 40
			4Y	-	A 32, A 36, D 32, D 36, E 32, E 36, F 32, F 36
			4Y 40	-	A 40, D 40, E 40, F 40

Figure 5.9 Butt weld test assemblies (two-run technique)

Each butt weld is to be welded in two runs, one from each side, using amperages, voltages and travel speeds in accordance with the recommendations of manufacturer and normal good welding practice.

After completion of the first run, the flux and welding slag are to be removed and the assembly is to be left in still air until it has cooled to 100°C, the temperature being taken in the centre of the weld, on the surface of

the seam. After welding, the test assemblies are not to be subjected to any heat treatment.

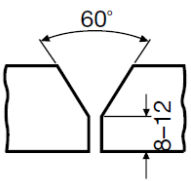
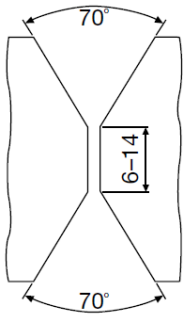
### 3.2.2 Radiographic examination

It is recommended that the welded assemblies are subjected to radiographic examination to ascertain if there are any defects in the weld prior to the preparation of test specimens.

### 3.2.3 Execution of tests

The test specimens indicated in Table 5.10a and shown in Figure 5.8 are to be prepared from each test assembly. Tests are to be performed according to A.8 Mechanical Testing Procedures. The Charpy V-notch impact test specimens are to be machined from each welded assembly from the positions and with the orientations shown in Figure 5.11.

### 3.2.4 Results of tests and requirements

The results of all tensile and impact tests are to comply with the requirements of Table 5.10b and 5.10c as appropriate. The position of fracture in the transverse tensile test is to be reported. The bend test specimens can be considered as complying with the requirements if, after bending, no crack or defect having any dimensions exceeding 3 mm can be seen on the outer surface of the test specimen.

### 3.2.5 Chemical analysis

The chemical analysis of the weld metal is to be supplied by the manufacturer, and is to include the content of all significant alloying elements.

## 4. Annual tests - upgrading

### 4.1 Annual tests

All establishments where approved wire/flux.

Annual tests are to consist of at least the following:

**4.1.1** Multirun technique: on deposited metal assembly and tests: 1 tensile and 3 impact tests.

**4.1.2** Two-run technique: one butt weld assembly with 20 mm minimum thickness plate and tests: 1 transverse tensile, 2 transverse bends and 3 impact tests. One longitudinal tensile test specimen is also to be prepared where the wire-flux combination is approved solely for the two-run technique.

The assemblies are to be prepared and tested in accordance with the requirements for initial approval.

Where a wire-flux combination is approved for welding both normal strength and higher strength steel, the latter steel is to be used for the preparation of the butt weld assembly required by 4.1.2.

## 4.2 Upgrading and rating

**4.2.1** Upgrading of wire-flux combinations in connection with the impact properties will be considered as detailed in B.8.2.2, and for wire-flux combinations approved for two runs welding, a butt-weld in the combinations are manufactured shall be subject to annual inspection.

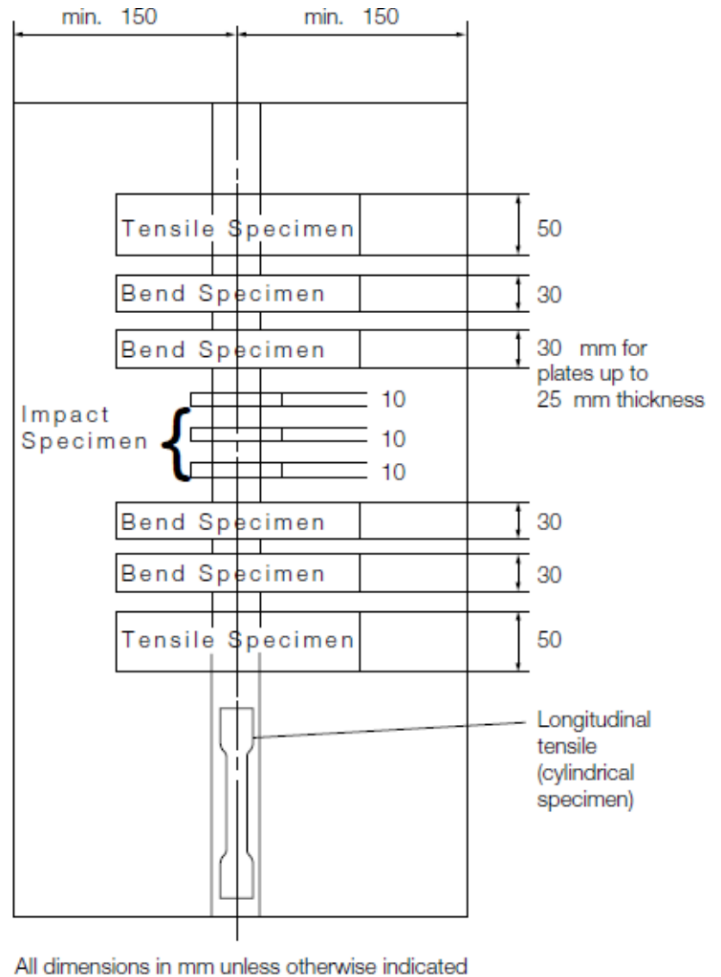
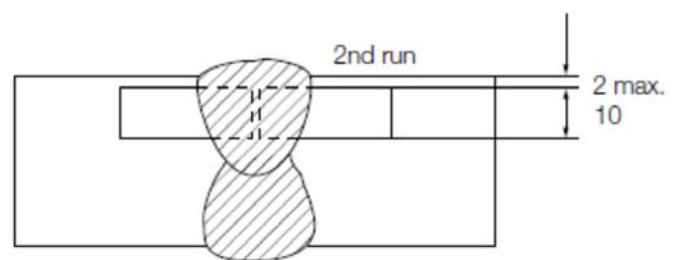

Figure 5.10 Test specimens



All dimensions in mm unless otherwise indicated

Figure 5.11 The Charpy V-notch impact test specimen



Maximum thickness approved is to be made and sampled for Charpy-V testing in accordance with 3.2.3.

**4.2.2** Upgrading of wire-flux combinations in connection with the tensile properties will be considered as detailed in B.8.2.3.

## **E. Consumables for use in eletroslag and electrogas vertical welding**

### **1. General**

**1.1** The requirements for the two-run technique as detailed in D are applicable for the approval of special consumables used in electro-slag and electro-gas vertical welding with or without consumable nozzles except as otherwise required by the following requirements especially as regards the number and kind of the test-pieces used for the mechanical tests and taken from the butt welded assemblies.

**1.2** For Grades 1Y, 2Y, 3Y, 4Y, 2Y40, 3Y40 and 4Y40 approval of the consumables may be restricted for use only with specific types of higher strength steel. This is in respect of the content of grain refining elements, and if general approval is required, a niobium treated steel is to be used for the approval tests.

**1.3** For these special welding consumables, the prescription 5.A4.1 may not be entirely applicable for technical reasons.

Where approval is requested for welding of both normal strength and higher strength steel two assemblies are to be prepared using higher strength steel. Two assemblies prepared using normal strength steel may also be required at the discretion of **TL**.

### **2. Butt weld tests**

#### **2.1 Preparation of test assemblies**

Two butt weld test assemblies are to be prepared, one of them with plates 20/25 mm thick, the other with plates 35/40 mm thick or more. The grade of the steel to be used for each one of these assemblies must be selected according to the requirements given in the Figure 5.12 for two-run submerged arc welding. The

chemical composition of the plate, including the content of grain refining elements is to be reported.

The welding conditions and the edge preparation are to be those recommended by the welding consumable manufacturer and are to be reported.

### **2.2 Radiographic examination**

It is recommended that the welded assemblies be subjected to a radiographic examination to ascertain if there are any defects in the weld prior to the preparation of test specimens.

### **2.3 Test series**

Each assembly shall be cut to give test specimens according to Figure 5.12.

The length of the assembly should be sufficient to allow the selection of all the test specimens:

- 2 longitudinal tensile test specimens with their axis at the centre of the weld.
- 2 transverse tensile test specimens.
- 2 side bend test specimens.
- 2 sets of 3 Charpy-V notch impact test specimens in accordance with Figure 5.12:
  - set with the notch in the axes of the weld,
  - set with the notch at 2 mm from the fusion line in the deposited metal.
- 2 macro-sections to the weld (towards the middle of the weld and towards one end).

### **2.4 Results to be obtained**

The results of the tensile, bend and impact tests are to comply with the requirements of paragraph D.3 (two-run welding) for the class of filler product in question.

## **3. Annual tests and up-grading**

**3.1** All factories which manufacture approved consumables for use in electroslag and electrogas welding must be subject to an annual inspection and tests in accordance with 5 A.3.2, A.7.4 and 7.5)

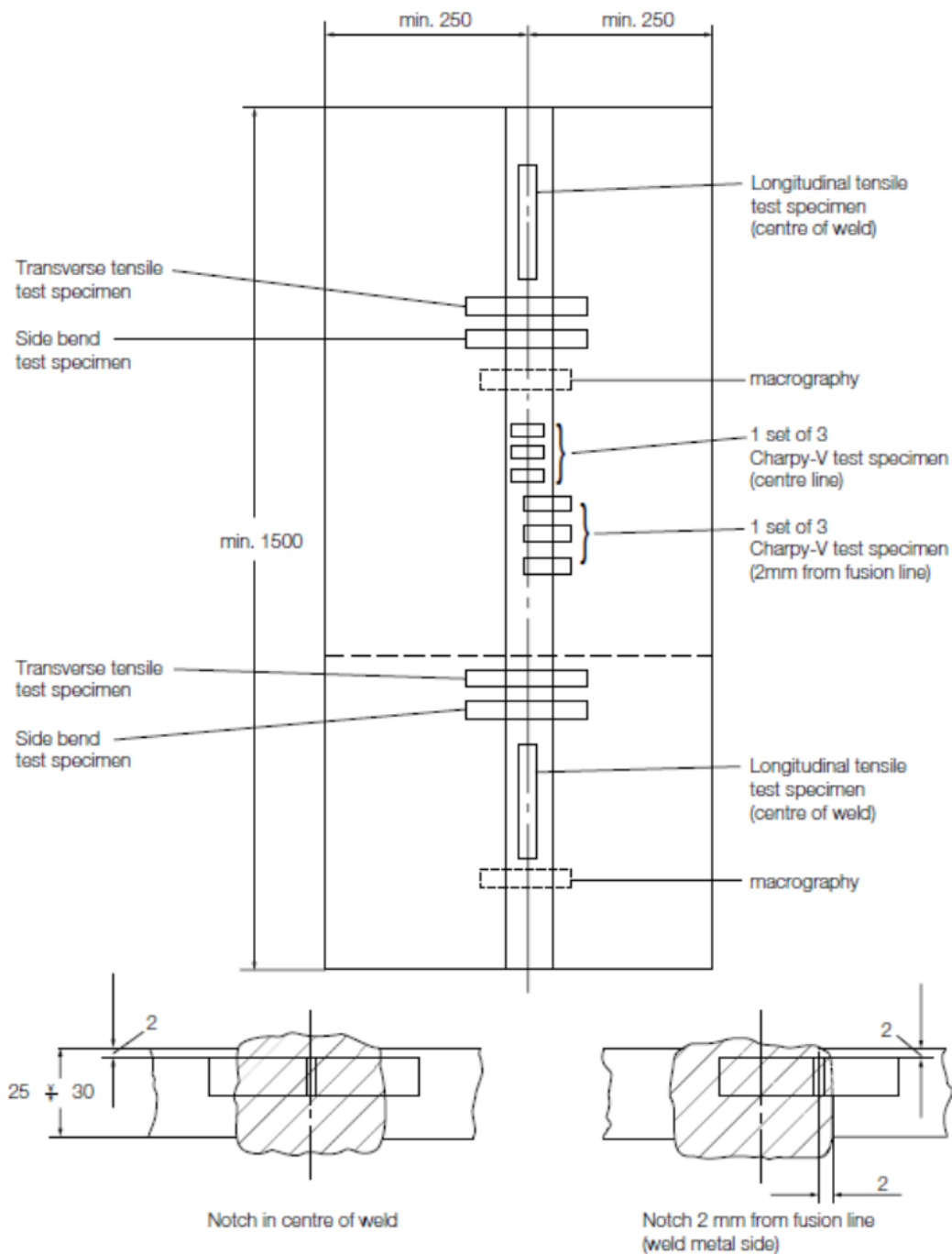

**Figure 5.12 Electroslag and electrogas butt weld test assembly**

**3.2** One test assembly must be prepared from plates 20/25 mm thick, and tested as indicated in E.2.

The following specimens are to be selected:

- 1 longitudinal tensile specimen from the axis of the weld,
- 1 transverse tensile specimen,
- 2 side bend specimens,
- 3 Charpy-V specimens notched at the centre of the weld (position 1 Figure 5.12),
- 3 Charpy-V specimens cut out transverse to the weld with their notches at 2 mm from the fusion line, in the weld,
- Macro section.

**3.3** The results to be obtained should meet the requirements given in D.3 (two-run welding) for the class of the consumables in question.

### 3.4 Upgrading and uprating

Upgrading and uprating will be considered only at the manufacturers request, at the time of annual testing. Generally, for this purpose, full tests from butt weld assemblies as indicated in E.2 will be required, irrespective of the other tests requested if the concerned consumable is also approved (and possibly upgraded or uprated) according to C or D.

## F. Approval of Welding Consumables for High Strength Quenched and Tempered Steels for Welded Structures

### 1. General

#### 1.1 Scope

**1.1.1** These requirements supplements the previous parts in this section and give the conditions of approval and inspection of welding consumables used for high strength quenched and tempered or TMCP steels for welded structures according to UR W16 (TL Rules,

Chapter 2, Section 3, C) with yield strength levels from 420 N/mm<sup>2</sup> up to 690 N/mm<sup>2</sup> and impact grades A, D, E and F.

Where no special requirements are given, those of previous parts in this section apply in analogous manner.

**1.1.2** The welding consumables preferably to be used for the steels concerned are divided into several categories as follows :

- Covered electrodes for manual welding,
- Wire-flux combinations for multirun **(2)** submerged arc welding,

---

**(2)** *Wire-flux combinations for single or two-run technique are subject to special consideration of TL.1,0% Mn, 0,03 % P, 0,03 % S.*

- Solid wire-gas combinations for arc welding (including rods for gas tungsten arc welding),
- Flux cored wire with or without gas for arc welding.

### 1.2 Grading, Designation

**1.2.1** Based on the yield strength of the weld metal, the welding consumables concerned are divided into six (yield) strength groups :

- Y42 - for welding steels with minimum yield strength 420 N/mm<sup>2</sup>
- Y46 - for welding steels with minimum yield strength 460 N/mm<sup>2</sup>
- Y50 - for welding steels with minimum yield strength 500 N/mm<sup>2</sup>
- Y55 - for welding steels with minimum yield strength 550 N/mm<sup>2</sup>
- Y62 - for welding steels with minimum yield strength 620 N/mm<sup>2</sup>
- Y69 - for welding steels with minimum yield strength 690 N/mm<sup>2</sup>

**1.2.2** Each of the six (yield) strength groups is further divided into three main grades in respect of charpy V-notch impact test requirements (test temperatures):

- Grade 3, test temperature -20°C
- Grade 4, test temperature -40°C
- Grade 5, test temperature -60°C

**1.2.3** Analogously to the designation scheme used in previous parts in this section the welding consumables for high strength quenched and tempered steels are subject to classification designation and approval as follows:

- According to F.1.2.2 with the quality grades 3,4 or 5
- With the added symbol Y and an appended code number designating the minimum yield strength of the weld metal corresponding 1.2.1: Y42, Y46, Y50, Y55, Y62 and Y69.
- With the added symbol H10 (HH) or H5 (HHH) for controlled hydrogen content of the weld metal,
- With the added symbol S (= Semi-automatic) for semi-mechanised welding,
- With the added symbol M designating multirun technique and is applicable only to welding consumables for fully mechanised welding,

**1.2.4** Each higher quality grade includes the one (or those) below. Grade A... and D... steels acc. to UR W16 (TL Rules, Chapter 2, Section 3, C) are to be welded using welding consumables of at least quality grade 3, grade E... steels using at least quality grade 4 and grade F... steels using at least quality grade 5., see the following Table :

Consumable Grade	Steel Grades covered
3Y..	D.. and A..
4Y..	E.., D.. and A..
5Y..	F.., E.., D.. and A..

Welding consumables approved with grades ..Y42, ..Y46 and ..Y50 are also considered suitable for welding steels in the two strength levels below that for which they have been approved. Welding consumables approved with grades ..Y55, ..Y62 and ..Y69 are also considered suitable for welding steels in the strength level below that for which they have been approved.

TL may, in individual cases, restrict the range of application in (up to) such a way, that approval for any one strength level does not justify approval for any other strength level.

### **1.3 Manufacture, testing and approval procedure**

**1.3.1** Manufacturer's plant, production methods and quality control measures shall be such as to ensure reasonable uniformity in manufacture, see also previous

parts in this section.

**1.3.2** Testing and approval procedure shall be in accordance with previous parts in this section and 2 and 3 and as required in previous parts in this section for the individual categories (types) of welding consumables mentioned in F.1.1.2 above.

## **2. Testing of the weld metal**

**2.1** For testing the deposited weld metal, test pieces analogous to those called for in, sections B,C,D respectively shall be prepared, depending on the type of the welding consumables (and according to the welding process). the base metal used shall be a fine-grained structural steel compatible with the properties of the weld metal, or the side walls of the weld shall be buttered with a weld metal of the same composition.

**2.2** The chemical composition of the deposited weld metal shall be determined and certified in a manner analogous to that prescribed in section B.2.2. The results of the analysis shall not exceed the limit values specified in the standards or by the manufacturer, the narrower tolerances being applicable in each case.

**2.3** Depending on the type of the welding consumables (and according to the welding process), the test specimens prescribed in A.8 and B.2, D.2, C.2 or C.3 respectively shall be taken from the weld metal test pieces in a similar manner.

**2.4** The mechanical properties must meet the requirements stated in Tables 5.11a and 5.11b The provisions of previous parts in this section apply in analogous manner to the performance of the tests, including in particular the maintenance of the test temperature in the notched bar impact test and the carrying out of results.

## **3. Testing on welded joints**

**3.1** Depending on the type of the welding consumables (and according to the welding process), the testing on the welded joints shall be performed on butt-weld test pieces in analogous manner to, sections B,C,D, or E respectively.

**3.2** Depending on the type of the welding consumables (and according to the welding process), the butt-weld test pieces called for in 3.1 shall be

welded in a manner analogous to that prescribed in UR W17 (TL Rules, Chapter 3, Section 5 and Section 12, E). The base metal used shall be a high-strength fine-grained structural steel with an appropriate minimum yield strength and tensile strength and compatible with the added symbol for which application is made.

**3.3** Depending on the type of the welding consumables (and according to the welding process), the test specimens described in previous parts in this

section shall be taken from the butt-weld test pieces.

**3.4** The mechanical properties must meet the requirements stated in Table 5.11c. The provisions of previous parts in this section apply in analogous manner to the performance of the tests, including in particular the maintenance of the test temperatures in the notched bar impact test and the requirements regarding the retest specimens.

**Table 5.11a Required toughness properties of the weld metal**

Quality grade	Test temperature [°C]	Minimum notch impact energy [J] (1)
3	-20	Y42: ≥ 47 Y46: ≥ 47
4	-40	Y50: ≥ 50 Y55: ≥ 55
5	-60	Y62: ≥ 62 Y69: ≥ 69

(1) Charpy V-notch impact test specimen, mean value of three specimens; for requirements regarding minimum individual values and retests, see UR W17 (TL Rules, Chapter 3, Section 5 and Section 12, E), section 3.3.2

**Table 5.11b Required strength properties of the weld metal**

Symbols added to quality grade	Minimum yield strength or 0.2% proof stress [N/mm <sup>2</sup> ]	Tensile Strength (1) [N/mm <sup>2</sup> ]	Minimum elongation [%]
Y42	420	530-680	20
Y46	460	570-720	20
Y50	500	610-770	18
Y55	550	670-830	18
Y62	620	720-890	18
Y69	690	770-940	17

(1) The tensile strength of the weld metal may be up to 10% below the requirements, provided that the results obtained with the transverse tensile specimens taken from the welded joints meet the minimum tensile strength requirements stated in Table 11c. The elongation is to be stated in the test report.

**Note:**  
For welding very large plate thicknesses where the “supporting effect” of the base material on either side of the weld no longer applies and the tensile strength of the weld metal also determines the tensile strength of the welded joint, it may be necessary, when applying footnote (1), to choose welding consumables of the next higher strength category (next higher added Symbol).

**Table 5.11c Required properties of welded joints**

Quality grade	Added symbol	Minimum tensile strength [N/mm <sup>2</sup> ]	Minimum notch impact energy, test temperature	Minimum bending angle (1)	Bend ratio D/t (2)
3 to 5 accordance with Table 11.a	Y42	530	Depending on the quality grade & yield strength in accordance Table 11.a	120°	4
	Y46	570			4
	Y50	610			4
	Y55	670			5
	Y62	720			5
	Y69	770			5

(1) Bending angle attained before the first incipient crack, minor pore exposures up to a maximum length of 3mm allowed.

(2) D = Mandrel diameter, t = specimen thickness

3.5 Where the bending angle required in Table 5.11c is not achieved, the specimen may be considered as fulfilling the requirements, if the bending elongation on a gauge length length  $L_0$  fulfills the minimum elongation requirements stated in Table 5.11b. The gauge length  $L_0 = L_s + t$  ( $L_s$  = width of weld,  $t$  = specimen thickness), see sketch below.

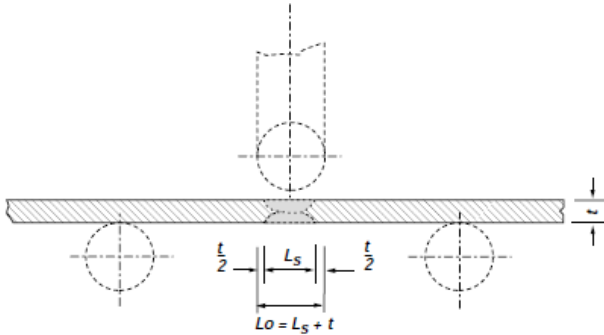

#### 4. Hydrogen test

4.1 The welding consumables, other than solid wire-gas combinations, shall be subjected to a hydrogen test in accordance with the mercury method to ISO 3690, or any other method such as the gas chromatographic method which correlates with that method, in respect of cooling rate and delay times during preparation of the weld samples, and the hydrogen volume determinations.

4.2 The diffusible hydrogen content of the weld metal determined in accordance with the provisions of section B.5 shall not exceed the limits given in Table 5.11d.

#### 5. Annual repeat test

The annual repeat tests specified in UR W 17 shall entail the preparation and testing of weld metal test pieces as prescribed in 2. In special cases, TL may require more extensive repeat tests.

Table 5.11d Allowable diffusible hydrogen content

Yield strength group	Hydrogen symbol	Maximum hydrogen content [ $\text{cm}^3/100 \text{ g}$ deposited weld metal]
Y42 Y46 Y50	H 10 (HH)	10
Y55 Y62 Y69	H 5 (HHH)	5

### G. Welding Consumables and Auxiliary Materials for Steels Tough at Subzero Temperatures

#### 1. General

1.1 The following provisions apply to welding consumables and auxiliary materials for welding of steels tough at subzero temperatures in accordance with the TL Chapter 2 - Material governing the fabrication of vessels, pipelines, etc. for liquefied gases.

##### Note:

According to TL Chapter 2, Materials, the steels tough at subzero temperatures used in shipbuilding fall into three categories: low-alloy carbon-manganese steels, nickel alloy steels and austenitic steels. The following paragraphs are therefore concerned with welding consumables and auxiliary materials for these three categories of materials. Other such products are to be treated in analogous manner; for aluminium alloys, see Section 8.

1.2 Depending on their nature and properties (type of alloy), welding consumables and auxiliary materials for welding of steels tough at subzero temperatures are classified and approved in the same way as those for high-strength (quenched and tempered) structural steels in accordance with F. or those for (austenitic) stainless steels or, where applicable, nickel alloy steels tough at subzero temperatures in accordance with I. No special indication of suitability for low-temperature service is given (except with the quality grade in accordance with F.); individual suitability for low-temperature service (test temperature for the notched bar impact test and proven notch impact energy) is indicated in the approval certificate. In general, the minimum service (design) temperature is 5 °C above this test temperature.

#### 2. Testing of the Weld Metal

2.1 Testing of the weld metal shall be carried out in accordance with the nature of the welding consumables and auxiliary materials, as described in F. and I. Unless otherwise stipulated in a particular case, the test temperatures for the notched bar impact test stated in these provisions shall be replaced by the test temperatures shown in Table 5.12.

**Table 5.12 Minimum design temperatures and test temperatures for the notched bar impact test**

Welding consumables and auxiliary materials for:	References to Rules and Standards relating to Materials	Minimum design temperature [°C]	Test temperature for the notched bar impact test [°C]
Fine grain structural steels for ammonia liquefied under pressure	in accordance with Chapter 2 - Material, Section 3, F. Table 3.16	0	- 20
High-strength (QT) fine grain structural steels with nominal yield strengths of 420 to 690 N/mm <sup>2</sup>	in accordance with Chapter 2 - Material, Section 3 F. Table 3.17	0	- 20
Other fine grain structural steels with nominal yield strengths of up to 355 N/mm <sup>2</sup>	e.g. to; EN 10028 Part 3	-45(1)	5° below minimum design temperature, but not above -20°C
Nickel steels with: 0,5% nickel 1,5% nickel 3,5% nickel 5% nickel 9% nickel	Steels conforming to EN 10028 Part 4 13MnNi6-3 15NiMn6 12Ni14 12Ni19 X8Ni9, X7Ni9	-55 -60 (2) -90 (2) -105 (2) (3) -165	-60 -65 (2) -95 (2) -110 (2) (-196) (3) -196
Austenitic steels	e.g. to EN.....(AISI) X2CrNi19-11/1.4306 (304L) X2CrNiMo17-13-2/1.4404 (316 L) X6CrNiTi18-10/1.4541 (321) X6CrNiNb18-10/1.4550 (347)	-165	- 196
<p>(1) <i>TL may approve lower design temperatures (down to a maximum - 55°C) provided that corresponding properties are demonstrated in the approval test.</i></p> <p>(2) <i>A lower design temperature may be approved by TL for QT steels with a 1,5 %, 3,5 % and 5 % nickel content; in these instances TL will specify the test temperatures.</i></p> <p>(3) <i>Steel with a 5 % nickel content may be approved for a minimum design temperature of - 165°C subject to the provisions stipulated in the Chapter 2 - Material, Section 3, F., Table 3.15, footnote (1); the test temperature is then - 196 °C.</i></p>			

**2.2** The requirements applicable to the strength and elongation of the weld metal are determined by those applying to the base material; see Chapter 2, Materials, Section 3, F., Section 4, D., Section 5, F. and Section 6, E. If particular base materials are welded with dissimilar welding consumables and auxiliary materials with strength values below those of the base material (e.g. in welding of 9 % nickel steel), the strength values used in the design calculations for the components shall apply. Unless otherwise stipulated, the minimum notch impact energy values at the test temperatures shown in Table 5.12 shall be 47 J (mean value) and 39 J (lowest individual value).

### 3. Testing on Welded Joints

The testing on the welded joints shall be performed in accordance with the nature of the welding consumables

and auxiliary materials as described in F. and I. In the case of welding consumables and auxiliary materials for nickel alloy steels, the welded joints shall be made with the base material for which approval has been solicited. In the case of such products for (low-alloy) carbon-manganese steels and austenitic steels, a base material of similar composition may be used. In all other respects, 2.1 and 2.2 apply in analogous manner.

### 4. Hydrogen Test

If a hydrogen test is stipulated for the welding consumables and auxiliary materials in question (e.g. according to F.4), it shall be performed in this case too. The requirements stipulated for each individual case apply.

### 5. Annual Repeat Tests

The annual repeat tests specified in A.3.1 shall entail

the preparation and testing of weld metal test pieces as prescribed in 2. **TL** may require more extensive repeat tests (see A.3.2, A.7.4 and A.7.5).

## H. Welding Consumables and Auxiliary Materials for High-Temperature Steels

### 1. General

**1.1** The following provisions apply to welding consumables and auxiliary materials for welding of high-temperature steels in accordance with the **TL** Rule Chapter 2 - Material governing the fabrication of steam boilers, pressure vessels, pipelines, etc. with high service temperatures.

**Note:**

*Under **TL** Chapter 2, Materials, this essentially applies to the carbon-manganese steels P235GH (HI), P265GH (H II), P295GH (17Mn4), P355GH (19Mn6), the molybdenum alloy steel 16Mo3 (15Mo3) and the chromium-molybdenum alloy steels 13CrMo4-5 (13CrMo4-4), 10CrMo9-10 (10CrMoI-10) and 11CrMo9-10 in accordance with EN 10028 Part 2. The following paragraphs are therefore concerned with welding consumables and auxiliary materials for these steels. Other such products are included if they can be classed among the materials also covered by the approval as shown in Table 5.13. Other welding consumables and auxiliary materials for other high-temperature steels are to be treated in analogous manner.*

**1.2** Welding consumables and auxiliary materials for high-temperature steels are classified into the quality grades shown in Table 5.13 according to their chemical composition (type of alloy) and mechanical (strength) characteristics and approved according to these grades.

The testing and approval of a steel in the left-hand columns of Table 5.13 encompasses the steel(s) in the right-hand columns. The different high-temperature strength properties are to be borne in mind. The Table applies in analogous manner to the corresponding grades of forgings and steel castings

**1.3** Welding consumables and auxiliary materials for components which are to undergo post-weld heat treatment must be tested and approved separately for the untreated condition and for each heat-treated condition. In general, the relevant conditions are:

U = Untreated (as-welded condition) and

S = Annealed to relieve stresses.

In special cases, normalizing (N) or quenching and tempering (V) may be necessary. The annealing temperatures and times shall be those applicable to the subsequent heat treatment of the components according to the standards, material data sheets, etc. Unless more precise data are given in these documents, the annealing temperatures and times specified in Section 9, Table 9.2 may be used

### 2. Testing the Weld Metal

**2.1** The testing of the weld metal shall be performed according to the nature of the welding consumable or auxiliary material (and, where applicable, according to the welding process) using test pieces and specimens in analogous manner to the provisions of B.2. In addition, for determining the 0,2 % proof stress at the maximum application temperature and at intermediate stages according to 2.3 two further round tensile specimens are to be taken from each test piece and tested. For this purpose, the test pieces shall be made correspondingly larger.

**2.2** The chemical composition of the deposited weld metal shall be determined and certified in a manner analogous to that prescribed in B.2.2. The results of the analysis shall not exceed the limit values specified in the standards (e.g. DIN 1599, EN ISO 21952 or EN ISO 17634) or by the manufacturer, the narrower tolerances being applicable in each case.

**2.3** As a minimum requirement, the test specimens prescribed in B.2.3, shall be taken from the weld metal test pieces and tested at room temperature. In addition, to determine the yield strength or the 0,2 % proof stress at the highest application temperature and at a second test temperature 100°C lower, two further round tensile test specimens shall be taken from the test pieces and tested.

**TL** may require further specimens to be taken and tests to be performed, e.g. determination of the 1,0 % proof stress, creep tests, notched bar impact tests on specimens subjected to ageing treatment or embrittlement tests.



2.4 The mechanical properties at room temperature must meet the requirements stated in Table 5.14 while the yield strength or the 0.2 % proof stresses at elevated temperature must conform to Table 5.15. If further tests are demanded by TL, the

requirements will be stipulated separately on a case-by-case basis. The provisions of A.7.6 and B.2.4, apply in analogous manner to the performance of the tests and any retests which may be required.

**Table 5.13 Welding consumables and auxiliary materials for high-temperature steels**

Quality grade	Testing and approval relating to steel (1)		Steels also covered by the approval (2)	
	Designation	Material No	Designation (1)	Material No.
235GH	P235GH	1.0345	-	-
265GH	P265GH	1.0425	P235GH	1.0345
295GH	P295GH	1.0481	P235GH P265GH	1.0345 1.0425
355GH	P355GH	1.0473	P235GH P265GH P295GH	1.0345 1.0425 1.0481
16Mo3	16Mo3	1.5415	P235GH P265GH P295GH P355GH	1.0345 1.0425 1.0481 1.0473
13CrMo4-5	13CrMo4-5	1.7335	16Mo3	1.5415
10CrMo9-10	10CrMo9-10	1.7380	16Mo3 13CrMo4-5	1.5415 1.7335
11CrMo9-10	11CrMo9-10	1.7383	16Mo3 13CrMo4-5 10CrMo9-10	1.5415 1.7335 1.7380

(1) Steel grades in accordance with TL's Rule Chapter 2 - Material or conforming to EN 10028.  
(2) Steel grades in accordance with TL's Rule Chapter 2 - Material or conforming to EN 10028 as well as other grades of forgings and steel castings.

**Table 5.14 Required properties of the weld metal at room temperature (+20°C)**

Quality grade	Minimum yield strength or 0,2% proof stress (1) $R_{eL}$ or $R_{p0,2}$ [N/mm <sup>2</sup> ]	Minimum tensile strength $R_m$ [N/mm <sup>2</sup> ]	Minimum elongation $A_5$ [%]	Minimum notch impact energy (2) [J]
235GH 265GH	285	480	22	47 (33)
295GH 355GH	360	520	22	
16Mo3	355	510	22	
13CrMo4-5	355	510	20	
10CrMo9-10 11CrMo9-10	400	520	18	

(1) The lower yield strength  $R_{eL}$  shall apply. Where the yield strength is not clearly defined, the 0,2 % proof stress ( $R_{p0,2}$ ) must be used.  
(2) Mean value of three specimens; for minimum individual values ( ) and retests, see B.2.4 and 2.5 as well as H.2.4.

Table 5.15 Yield strength resp. 0,2% proof stress at elevated temperatures

Quality grade	Minimum yield strength resp. 0,2% proof stress (1) at a temperatures °C									
	50	100	150	200	250	300	350	400	450	500
	[N/mm <sup>2</sup> ]									
235GH	206	190	180	170	150	130	120	110	-	-
265GH	234	215	205	195	175	155	140	130	-	-
295GH	272	250	235	225	205	185	170	155	-	-
355GH	318	290	270	255	235	215	200	180	-	-
16Mo3	-	-	-	215	200	170	160	150	145	140
13CrMo4-5	-	-	-	230	220	205	190	180	170	165
10CrMo9-10	-	-	-	215	200	170	160	150	145	140
11CrMo9-10	-	-	-	-	255	235	225	215	205	195

**(1)** The lower yield strength ( $R_{eL}$ ) shall apply. Where the yield strength is not clearly defined, the 0,2% proof stress ( $R_{p0,2}$ ) must be used.

### 3. Testing on Welded Joints

**3.1** Depending on the nature of the welding consumables and auxiliary materials (and on the welding process concerned), the testing on the welded joints shall be performed on butt-weld test pieces in analogous manner to the provisions of B.3,

**3.2** The butt-weld test pieces shall be prepared in analogous manner to the procedures described in B.3.2, taking Table 5.14 into account. Wherever possible, the base material should be a high-temperature steel corresponding to the quality grade in question.

**3.3** Depending on the welding process, the test specimens described in B.3.3, shall be taken from the butt-welded test pieces, unless otherwise specified.

**3.4** The mechanical characteristics of the welded joint must meet the requirements for the weld metal stated in Table 5.14; except in the case of the yield strength. The provisions of A.7.6, B.3.4 apply in analogous manner to the performance of the tests and any retests which may be required.

### 4. Hydrogen Test

If a hydrogen test is required, it shall be performed in accordance with B.5. The diffusible hydrogen content shall not exceed 10 ml per 100 g of deposited weld metal.

### 5. Testing for Hot Cracks

If testing for hot cracks is required, this shall be performed in accordance with B.4 or the relevant standards (e.g. EN ISO 17641-2).

### 6. Annual Repeat Tests

**6.1** The annual repeat tests specified in A.3.1 shall entail the preparation and testing of weld metal test pieces as prescribed in 2. TL may require more extensive repeat tests (see A.3.2, A.7.4 and A.7.5).

**6.2** The annual repeat tests shall be performed according to the prescribed scope for both the untreated condition and the various (approved) heat treated conditions (see 1.3).

## I. Austenitic and Austenitic-Ferritic Welding Consumables and Auxiliary Materials for Stainless Steels, Non-Magnetic Steels and Nickel Alloy Steels Tough at Subzero Temperatures

### 1. General

1.1 The following provisions apply to welding consumables and auxiliary materials for welding of stainless (austenitic) steels and steel castings, plates clad with these materials and joints of these materials with unalloyed and low-alloy (hull) structural steels. They also apply to welding consumables and auxiliary materials for welding of non-magnetic steels, nickel alloy steels tough at subzero temperatures and other,

similar steels. Austenitic welding consumables and auxiliary materials for clad welding and for joining difficult weldable (ferritic) materials are to be treated in analogous manner.

#### Notes:

*In (tanker) shipbuilding, the current practice is to use, in the main, the (austenitic or austenitic-ferritic) molybdenum alloy stainless steels listed in the three left-hand columns of Table 5.21. For equipment components, use is also made of, among others, steels of types 5CrNi8-10 (mat. no. 1.4301, AISI 304) and X6CrNiTi18-10 (mat. no. 1.4541, AISI 321). The following paragraphs therefore relate to welding consumables and auxiliary materials for these base materials including their joints with hull structural steels. Furthermore, the welding consumables and auxiliary materials for which TL had already granted approval have also been included. Welding consumables and auxiliary materials for other base materials should, where applicable, be allocated to the appropriate categories and treated in analogous manner.*

*Inert gases with 1 to 3 % of oxygen added or those with a maximum of 2,5 % CO<sub>2</sub> added can be used as shielding gases for welding austenitic welding consumables in the range of application specified in 1.1. Those inert gases with a high level of nitrogen added can be used for steels which contain nitrogen. Gas mixtures of the type M 21 (see Table 5.8) with a maximum of 18 % of CO<sub>2</sub> added may only be used with slag-forming flux-cored wire electrodes. Approvals for (flux-cored) wire-gas combinations are also granted accordingly.*

1.2 Welding consumables and auxiliary materials for welded joints uniting (austenitic or austenitic-ferritic) stainless steels to one another are classified into the quality grades shown in Table 5.18 according to the chemical composition (material no.) and mechanical (strength) characteristics of the base materials to be welded. The testing and approval of a steel in the left-hand column of the Table encompasses the steel(s) in the right-hand column, subject to separate consideration of the corrosion conditions in each case. The Table applies in analogous manner to the corresponding grades of forgings and steel castings.

1.3 Welding consumables and auxiliary materials for welding of non-magnetic stainless steels are approved according to a quality grade corresponding to the chemical composition (material no.) of the weld metal. Table 5.17 contains a number of examples. The testing and approval of a steel in the left-hand column encompasses the steel(s) in the right-hand column, subject to separate consideration of the corrosion conditions in each case. The Table applies in analogous manner to the corresponding grades of forgings and steel castings.

1.4 Welding consumables and auxiliary materials for joining (austenitic or austenitic-ferritic) stainless steels to unalloyed or low-alloy steels, for intermediate runs in welding of clad plates and for clad welds are approved according to a quality grade corresponding to the chemical composition of the weld metal. Table 5.18 gives a number of examples. Approval is granted with due regard to the mechanical and other properties in relation to the base materials concerned and/or for a particular type of application for which suitability has been proved.

1.5 Austenitic welding consumables and auxiliary materials, including those made of nickel based alloys for welding of nickel steels tough at subzero temperatures are classified into quality grades as shown in Table 5.19 according to the chemical composition (material no.) and mechanical (strength and toughness) characteristics of the base materials to be welded. The testing and approval of a steel in the left-hand column encompasses the steel(s) in the right-hand column. The Table applies in analogous manner to the corresponding grades of forgings and steel castings.

Table 5.16 Austenitic welding consumables and auxiliary materials for welding of stainless steel

Quality grade	Testing and approval relating to steel		Steels also covered by the approval	
	Designation	Material No./AISI	Designation	Material No./AISI
4301	X5CrNi18-10	1.4301/304	-	-
4306	X2CrNi19-11	1.4306/304 L	X5CrNi18-10 C2CrNi18-9 GX6CrNi18-9	1.4301/304 1.4307/3047L 1.4308/-
4307	X2CrNi18-9	1.4307/304 L	X5CrNi1810	1.4301/304
4404	X2CrNiMo17-13-2	1.4404/316 L	X5CrNi18-10 X2CrNi19-11 GX6CrNi18-9 X5CrNiMo17-12-2 GX6CrNiMo18-9	1.4301/304 1.4306/304L 1.4308/- 1.4401/316 1.4408/-
4429	X2CrNiMoN17-13-3	1.4429/316LN	X2CrNi18-10 X5CrNiMo17-12-2 X2CrNiMo17-13-2 X2CrNiMoN17-12-2 GX6CrNiMo18-9 X2CrNiMo18-14-3 X5CrNiMo17-13-3 X6CrNiMoTi17-12-2 X10CrNiMoTi18-12 X6CrNiMoNb17-12-2 X10CrNiMoNb18-12	1.4311/303 LN 1.4401/316 1.4404/316 L 1.4406/316 LN 1.4408/- 1.4435/316 L 1.4436/316 1.4571/316 Ti 1.4573/- 1.4580/316 Cb 1.4583/318
4435	X2CrNiMo18-14-3	1.4435/316 L	X5CrNi18-10 X2CrNi19-11 GX6CrNi18-9 X5CrNiMo17-12-2 X2CrNiMo17-13-2 GX6CrNiMo18-9	1.4301/304 1.4306/304L 1.4308/- 1.4401/316 1.4404/316L 1.4408/-
4438	X2CrNiMo18-16-4	1.4438/317L	X5CrNiMo17-12-2 X2CrNiMo17-13-2 X2CrNiMo18-14-3 X5CrNiMo17-13-3	1.4401/316 1.4404/316L 1.4435/316L 1.4436/316
4439	X3CrNiMoN17-13-5	1.4439/(317LN)	X2CrNiMoN17-12-2 X2CrNiMoN17-13-3 X2CrNiMo18-16-4 GX2CrNiMoN17-13-4 GX6CrNiMo17-13 X5CrNiMo17-13	1.4406/316 LN 1.4429/316 LN 1.4438/317 L 1.4446/- 1.4448/- 1.4449/317
4462	X2CrNiMoN22-5	1.4462/-	X8CrNiMo27-5 X6CrNiMo24-8-2 X4CrNiMoNb25-7	1.4460/329 1.4463/- 1.4582/329
4550	X6CrNiNb18-10	1.4550/347	X5CrNi18-10 X2CrNi19-11 GX6CrNi18-9 X6CrNiTi18-10 GX7CrNiNb18-9	1.4301/304 1.4306/304L 1.4308/- 1.4541/321 1.4552/-
4571	X6CrNiMoTi17-12-2	1.4571/316Ti	X5CrNi18-10 X2CrNi19-11 GX6CrNi18-9 X5CrNiMo17-12-2 X2CrNiMo17-13-2 GX6CrNiMo18-9 X2CrNiMo18-14-3 X5CrNiMo17-13-3 X6CrNiTi18-10 X6CrNiNb18-10 GX7CrNiNb18-9 X10CrNiMoTi18-12 X6CrNiMoNb17-12-2 GX7CrNiMoNb18-2 X10CrNiMoNb18-12	1.4301/304 1.4306/304 L 1.4308/- 1.4401/316 1.4404/316 1.4408/- 1.4435/316 L 1.4436/316 1.4541/321 1.4550/347 1.4552/- 1.4573/- 1.4580/316 Cb 1.4581/- 1.4583/318

**Table 5.17 Austenitic welding consumables and auxiliary materials for welding of non-magnetic stainless steels**

Quality grade	Testing and approval relating to steel		Steels also covered by the approval	
	Designation	Mat. No.	Designation	Mat. No.
3954	X2CrNiMnMoNNb21-16-5-3	1.3964	X4CrNiMnMoN19-13-8	1.3948
			X2CrNiMoN22-15	1.3951
			X2CrNiMoN18-14-3	1.3952
			X2CrNiMo18-15	1.3953
3984	X2CrNiMnMoNNb23-17-6-3	1.3974	X2CrNiMnMoNNb21-15-7-3	1.3914
			X2CrNiMoN22-15	1.3951
			X2CrNiMoN18-14-3	1.3952
			X2CrNiMnMoNNb21-16-5-3	1.3964

**Table 5.18 Austenitic welding consumables and auxiliary materials for joining stainless steels to unalloyed or low-alloy steels, for intermediate runs and for clad welds (examples)**

Quality grade	Welding consumable (weld metal)		Usage (Instruction) (2)
	Designation (1)	Mat. No /AWS	
4332	E 23 12 nC X2CrNi24-12	(1.4332) / E 309 L 1.4332 / E 309 L	Intermediate runs for welded joints between clad plates of similar composition. Welded joints between heat resistant CrNi steels, joints between stainless and unalloyed or low-alloy steels. Clad welds.
4370	E 18 8 Mn 6 X15CrNiMn18-8	(1.4370) / (E 307) 1.4370 / -	Joints between stainless and unalloyed or low-alloy steels.
4431	E 20 10 3 X12CrNiMo19-10	1.4431 / - 1.4431 / -	As for 4370
4459	E 23 12 2 X8CrNiMo23-13	1.4459 / E 309 Mo (1.4459) / (E 309 Mo)	As for 4332
<p>(1) <i>First line (E...): Designation for covered electrode, second line: designation for (flux-cored) wire -gas and wire flux combinations.</i></p> <p>(2) <i>The manufacturer's information given for the individual product are decisive abbr. information mentioned in the approval</i></p>			

## 2. Testing of the Weld Metal

**2.1** For testing the deposited weld metal, test pieces analogous to those called for in B.2 (only one test piece welded in the down-hand position) shall be prepared, depending on the nature of the welding consumables and auxiliary materials (and according to the welding process). The base material used shall be a stainless steel of the same composition, or the side walls of the weld shall be buffered with a weld metal of such composition.

**2.2** The chemical composition of the deposited weld metal shall be determined and certified in a manner analogous to that prescribed in B.2.2. As an

alternative, the chemical composition may be determined in a manner analogous to EN ISO 15792-1 by analysis of a build-up weld. The results of the analysis shall not exceed the limits specified in the standards or by the manufacturer, the narrower tolerances being applicable in each case.

For the welding consumables and auxiliary materials specified in Tables 5.18 and 5.19, the pitting resistance equivalent (% Cr + 3,3 % Mo) shall be at least 1 % higher than that of the base material on which the test was carried out resp. on which approval was based. The analysis of the weld metal and an average chemical composition determined from the data given in the standards shall be the determining factors in such a case.

**2.3** Depending on the nature of the welding consumables and auxiliary materials (and according to the welding process), the test specimens shall be taken from the weld metal test pieces in a manner analogous to the provisions of B.2.3,

**2.4** The mechanical properties must meet the requirements stated in Table 5.20. The provisions of B.2.4, apply in analogous manner to the performance of the tests and the carrying out of retests. For the welding consumables and auxiliary materials referred to in 1.4, the requirements depend on the particular application

and are determined on a case-by- case basis. The notch impact energy values demonstrated during the test and also the test temperatures are indicated in the approval certificate.

Welding consumables and auxiliary materials for joining stainless to normal-strength or higher-strength hull structural steels must, as a minimum requirement, meet the requirements relating to those for the latter. For the welding consumables and auxiliary materials referred to in 1.5, G.2.2 should also be noted.

**Table 5.19 Austenitic welding consumables and auxiliary materials for welding of nickel steels tough at subzero temperatures (examples)**

Quality grade	Testing and approval relating to steel (1)		Steels also covered by the approval (1)	
	Designation	Mat. No.	Designation	Mat. No.
5637	12Ni14 (%3,5Ni)	1.5637	--	--
5680	12Ni19 (%5 Ni)	1.5680	12Ni14 (%3,5 Ni)	1.5637
5662	X8Ni9 (%9 Ni)	1.5662	12Ni14 (%3,5 Ni) G9Ni14 (%3,5 Ni) 12Ni19 (%5 Ni)	1.5637 1..... 1.5680
5663	X7Ni9 (%9 Ni)	1.5663	12Ni14 (%3,5 Ni) G9Ni14 (%3,5 Ni) 12Ni19 (%5 Ni) X8Ni9 (%9 Ni)	1.5637 1..... 1.5680 1.5662
<b>(1)</b> <i>Steels conforming to EN 10028-4</i>				

### 3. Testing on Welded Joints

**3.1** Depending on their nature (and on the welding process concerned), the testing on welded joints made with the welding consumables and auxiliary materials referred to in 1.2, 1.3 and 1.5 shall be performed on butt-weld test pieces analogous to those prescribed in B.3.1. For the welding consumables and auxiliary materials covered by 1.4, testing of welded joints is required only if the products are used wholly or chiefly for making welded joints or where, in welded joints, they constitute a substantial proportion of the weld section (as in the case of the intermediate runs of welds joining clad plates). However, TL may call for specimen welds to prove the satisfactory performance of these products in the various positions for which approval is solicited

(see also A.6.). For welding consumables and auxiliary materials covered by 1.3 which are used exclusively for clad welding, the scope of the tests to be applied shall be determined on a case-by-case basis.

**3.2** Depending on the nature of the welding consumables and auxiliary materials (and according to the welding process), the butt-weld test pieces called for in 3.1 shall be welded in a manner analogous to that prescribed in B.3.2 The base material used shall be a steel of the same or similar composition in accordance with Tables 5.16, 5.17 and 5.19 and shall possess at

least the mechanical properties indicated in Table 5.15. An analogous procedure shall be adopted in the case of the welding consumables and auxiliary materials covered by 1.4 and Table 5.15.

3.3 Depending on the nature of the welding consumables and auxiliary materials (and according to

the welding process), the test specimens prescribed in B.3.3, shall be taken from the butt-welded test pieces.

**Table 5.20 Required properties of the weld metal**

Quality grade	Minimum 0,2% proof stress [N/mm <sup>2</sup> ]	Tensile strength [N/mm <sup>2</sup> ]	Minimum elongation [%]	Minimum notch impact energy [J] (1)	Test temperature [°C]
4306	195	500 - 700	30	47 (33)	+ 20 (2)
4404	205	510 - 710	30		
4429	295	580 - 800	30		
4435	205	510 - 710	30		
4438	205	510 - 710	30		
4439	295	580 - 800	30		
4462	480	680 - 900	25	35 (24)	- 30
4550	205	510 - 740	30	47 (33)	+ 20 (2)
4571	225	500 - 740	30		
3954	430	700-950.	30	70 (49)	+ 20
3984	510	850-1050.			
5637	355	490 - 640	22	47 (33)	- 95 (3)
5680	390	530 - 840	20		- 196 (3)
5662	490 (5)	640 (5)- 840	18		- 110(-196) (3)(4)
5663	585	680-820	18		- 196 (3)
<p>(1) Means value of three specimens; for individual values ( ) and retests, see I.2.4.  (2) In the case of low-temperature applications, special requirements apply: see G. (G.2.2).  (3) See G. (and G.2.2).  (4) If quality grade 5680 (welding of 5 % nickel steel) is to be applied at a minimum design temperature of -165°C. The test temperature shall be -196°C.  (5) If the "as delivered" condition (of the base material) is HT 640, this welding consumable shall also be approved for the as-delivered condition HT 680 of the base materials. In such a case the same minimum requirements as stated for quality grade 5663 shall apply.</p>					

3.4 The mechanical properties must meet the requirements stated in Table 5.20. TL may agree to the application in analogous manner of footnote (1) in Table 5.11(b) also for the austenitic welding consumables and auxiliary materials covered by this section.

#### 4. Testing of Resistance to Intergranular Corrosion

4.1 Testing of resistance to intergranular corrosion shall be performed in accordance with EN ISO 3651-2 on test specimens with intersecting butt welds using the copper sulphate - sulphuric acid method. No cracks may be detected and the metallographically measured depth of penetration of the attack at the grain boundaries shall not exceed 0,05 mm.

4.2 In the case of special corrosion conditions or particular materials, TL may stipulate other corrosion

tests as an additional or alternative measure, e.g. testing of resistance to pitting under corrosive attack by chlorides, e.g. by seawater.

#### 5. Testing for Hot Cracks

5.1 Testing for hot cracks are to be performed in analogous manner to the provisions of B.4. or EN ISO 17641-2 on the shape 2 test piece prescribed for austenitic welding consumables and auxiliary materials.

5.2 Other methods of testing for hot cracks may be agreed with TL.

#### 6. Annual repeat tests

6.1 The annual repeat tests specified in A.3.1 shall entail the preparation and testing of weld metal test pieces as prescribed under 2. (determination of the mechanical properties and chemical composition of the weld metal). If the tensile strengths prescribed in Table

5.20 are not attained and footnote (1) in Table 5.11b applies analogously, the repeat test, too, shall include the testing of flat tensile specimens taken from the welded joints.

**6.2** In special cases, TL may require more extensive repeat tests (see A.3.2, A.7.4 and A.7.5).

## **J. Requirements for Welding Consumables for Aluminium Alloys**

### **1. General**

#### **1.1 Scope**

**1.1.1** These requirements give the conditions of approval and inspection of welding consumables to be used for hull construction and marine structure aluminium alloys according to (Chapter 2 – Material, Rules Section 8, Ref: UR W 25). Where no special requirements are given herein, e.g. for the approval procedure or for the welding of test assemblies and testing, those of previous parts of this section (Ref:UR W17) apply in analogous manner.

**1.1.2** The welding consumables preferably to be used for the aluminium alloys concerned are divided into two categories as follows:

W = Wire electrode - and wire - gas combinations for metal-arc inert gas welding (MIG, 131 acc. to ISO 4063), tungsten inert gas arc welding (TIG, 141) or plasma arc welding (15),

R = Rod - gas combinations for tungsten inert gas arc welding (TIG, 141) or plasma arc welding (15).

#### **1.2 Grading, Designation**

**1.2.1** The consumables concerned are graded as mentioned in Table 5.21, in accordance with the alloy type and strength level of the base materials used for the approval tests.

**1.2.2** Approval of a wire or a rod will be granted in

conjunction with a specific shielding gas acc. to Table 5.22 or defined in terms of composition and purity of "special" gas to be designated with group sign "S". The composition of the shielding gas is to be reported. The approval of a wire or rod with any particular gas can be applied or transferred to any combination of the same wire or rod and any gas in the same numbered group as defined in Table 5.22, subject to the agreement of TL.

### **1.3 Manufacture, testing and approval procedure**

**1.3.1** Manufacturer's plant, production methods and quality control measures shall be such as to ensure reasonable uniformity in manufacture, see also UR W 17.

**1.3.2** Testing and approval procedure shall be in accordance with previous parts of this section and sections 2 and 3 and as required in previous parts of this section for the individual categories (types) of welding consumables, shielding gases and their mixtures mentioned in 1.1.2 above.

## **2. Testing, required properties**

### **2.1 Testing of the deposited weld metal**

**2.1.1** For the testing of the chemical composition of the deposited weld metal, a test piece according to

Figure 5.13 shall be prepared. The size depends on the type of the welding consumable (and on the welding process) and shall give a sufficient amount of pure weld metal for chemical analysis. The base metal used shall be compatible with the weld metal in respect of chemical composition.

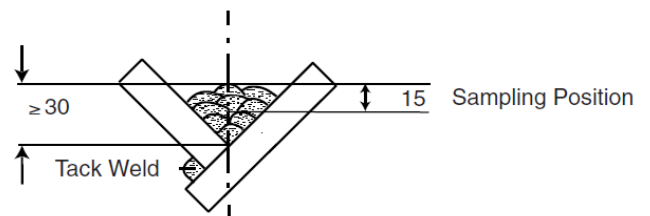

**Figure 5.13 Deposited weld metal test assembly**

**2.1.2** The chemical composition of the deposited weld metal shall be determined and certified in a manner analogous to that prescribed in UR W 17 and section C.2.3. The results of the analysis shall not exceed the limit values specified by the manufacturer.



Table 5.21 Consumable grades and base materials for the approval test

Consumable quality grade	Base material for the tests (Symbol)	
	Alloy Designation	
	Numerical	Chem. symbol
RA/WA	5754	AlMg3
RB/WB	5086	AlMg4
RC/WC	5083	AlMg4.5Mn0,7
	5383	AlMg4.5Mn0.9
	5456	AlMg5
	5059	-
RD/WD	6005A	AlSiMg(A)
	6061	AlMg1SiCu
	6082	AlSi1MgMn

**Note:**  
Approval on higher strength AlMg base materials covers also the lower strength AlMg grades and their combination with AlSi grades

Table 5.22 Compositional limits of shielding gases and mixtures to be used

Group	Gas composition (Vol. %) (1)	
	Argon	Helium
I - 1	100	---
I - 2	---	100
I - 3	Rest	> 0 to 33
I - 4	Rest	> 33 to 66
I - 5	Rest	> 66 to 95
S	Special gas, composition to be specified, see 1.2.2	

(1) Gases of other chemical composition (mixed gases) may be considered as „special gases“ and covered by a separate test.

## 2.2 Testing of butt weld assemblies

**2.2.1** The testing of the welded joints shall be performed on butt-weld test assemblies according to Figure 5.14 and 5.15, made from materials as given in Table 5.21, in an analogous manner to and B.3, C.2.5, C.3.5 or C.4.2 respectively (Ref:UR W 17 (Sections 4.3,6.2.5,6.3.5 or 6.4.2)).

**2.2.2** Butt weld test assemblies according to Figure

5.14 with a thickness of 10 to 12 mm are to be prepared for each welding position (downhand, horizontal-vertical, vertical-upward and overhead) for which the consumable is recommended by the manufacturer; except that consumables satisfying the requirements for downhand and vertical-upward positions will be considered as also complying with the requirements for the horizontal-vertical position subject to the agreement of TL.

T = Flat tensile test specimen  
 B<sub>C</sub> = Face bend test specimen  
 B<sub>R</sub> = Root bend test specimen  
 M = Macrographic section

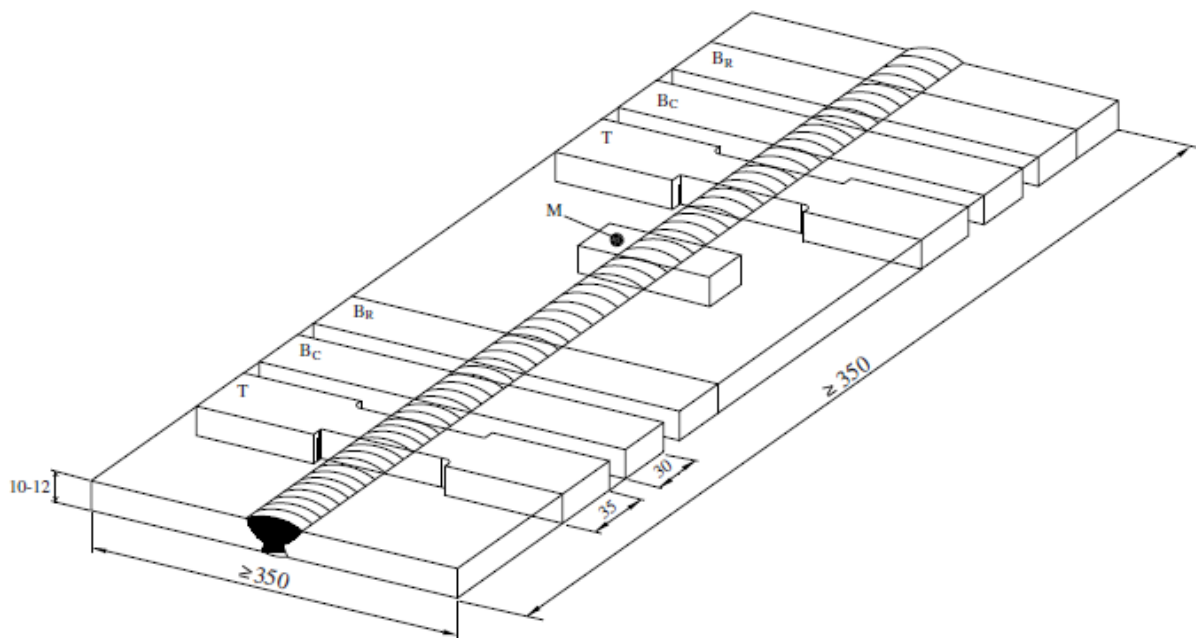

**Notes:**

- 1) Edge preparation is to be single V or double V with 70° angle.
- 2) Back sealing runs are allowed in single V weld assemblies.
- 3) In case of double V assembly both sides shall be welded in the same welding position.

**Figure 5.14 Butt weld test assembly for positional welding**

**2.2.3** Additionally one test assembly according to Figure 5.15 with a thickness of 20 to 25 mm is to be welded in the downhand position only.

**2.2.4** On completion of welding, assemblies must be allowed to cool naturally to ambient temperature.

Welded test assemblies and test specimens must not be subjected to any heat treatment.

Grade D assemblies should be allowed to naturally ageing for a minimum period of 72 hours from the completion of welding before testing is carried out.

**2.2.5** The test specimens shown in Figure 5.14 and

Figure 5.15 and described in previous parts of this section shall be taken from the butt weld test assemblies.

**2.2.6** The mechanical properties must meet the requirements stated in Table 5.23. The provisions of previous parts of this section apply in analogous manner to the performance of the tests, including the requirements regarding the annual repeat tests and retesting. The position of the fractures is to be stated in the report. The macrographic specimen shall be examined for imperfections such as lack of fusion, cavities, inclusions, pores or cracks.

- T = Flat tensile test specimen  
 B<sub>C</sub> = Face bend test specimen  
 B<sub>R</sub> = Root bend test specimen  
 M = Macrographic section

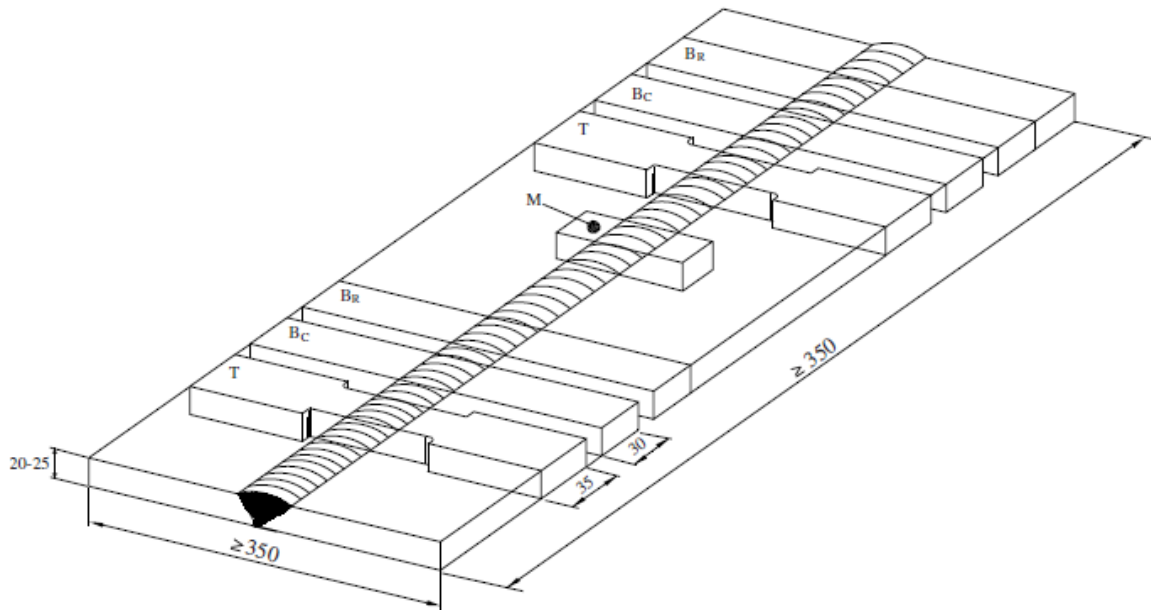

**Notes:**

- 1) Edge preparation is to be a single V with 70° angle.
- 2) Back sealing runs are allowed.

**Figure 5.15 Additional butt weld test assembly in downhand position**

**Table 5.23 Requirements for the transverse tensile and bend tests**

Grade	Base material used for the test	Tensile Grade strength $R_m$ [N/mm <sup>2</sup> ] min.	Former diameter	Bending Angle 1) [°] min.
RA/WA	5754	190	3t	180
RB/WB	5086	240	6t	
RC/WC	5083	275	6t	
	5383 or 5456	290	6t	
	5059	330	6t	
RD/WD	6061, 6005A or 6082	170	6t	

**Note:**

- 1) During testing, the test specimen shall not reveal any one single flaw greater than 3 mm in any direction. Flaws appearing at the corners of a test specimen shall be ignored in the evaluation, unless there is evidence that they result from lack of fusion.

### 3. Annual repeat tests

3.1 The annual repeat tests shall entail the preparation and testing of the deposited weld metal test assembly as prescribed under 2.1.1 (5.13) and of the downhand butt weld test assembly according to 2.2.2 (5.14).

## K. Welding Consumables and Auxiliary Materials for Copper and Copper Alloys

### 1. General

1.1 The following provisions apply to welding consumables and auxiliary materials for the welding of copper and copper alloys conforming to TL's Rules for Materials and used for structural components in shipbuilding (e.g. rudders) and especially for pipelines conveying seawater.

**Note:**

*According to TL's Chapter 2, Materials, besides copper and high-strength brass, the copper-nickel alloys CuNi10Fe1Mn and CuNi30Mn1Fe as well as certain cast copper alloys (used in the manufacture of propellers) are mainly used for welding purposes. In accordance with current approval practice, the following items therefore relate to welding consumables and auxiliary materials for these base materials; other such products for the welding of other cast alloys are to be treated in analogous manner.*

1.2 Welding consumables and auxiliary materials for welding of copper and copper alloys are classified into the quality grades shown in Table 5.24 on the basis of their chemical composition (type of alloy) and mechanical (strength) properties. Testing and approval in respect of a base material in the left-hand column of Table 5.24 also encompasses the base material(s) shown in the right-hand column.

### 2. Testing of the Weld Metal

2.1 Unless otherwise stipulated, the testing of the weld metal shall consist of a chemical analysis of the deposited weld metal and a tensile test analogous to that described in B.2 (only one test piece to be welded in the down-hand position).

2.2 The chemical composition shall be determined and certified in a manner analogous to that prescribed in B.2.2. The results of the analysis shall not exceed the limits specified in the standards (e.g. EN ISO 8836) or by the manufacturer, the narrower tolerances being applicable in each case.

### 3. Testing on Welded Joints

3.1 The testing on welded joints shall be performed in a manner analogous to that prescribed in J for welding consumables and auxiliary materials for aluminium alloys or, with TL's consent, in accordance with the standards (e.g. EN ISO 24373).

3.2 The mechanical properties must conform to the required properties of the base materials shown in Table 5.25. Different values for these properties are only permissible with TL's consent and are to be taken into account where applicable when dimensioning the components.

### 4. Annual Repeat Tests

4.1 The annual repeat tests called for in A.3.1 shall entail the preparation and testing of a butt-weld test piece in accordance with 3.1 welded in the down-hand position as in the case of aluminium alloys (see J.4.1).

## L. Welding Consumables and Auxiliary Materials for Nickel and Nickel Alloys

### 1. General

1.1 The following provisions apply to welding consumables and auxiliary materials for welding of nickel and nickel alloys.

**Note:**

*According to current approval practice, the welding consumables and auxiliary materials shown in the left-hand column of Table 5.26 are used. The following items therefore relate to welding consumables and auxiliary materials for these materials, but also cover such products for joining of different materials by welding (e.g. austenitic steels to ferritic/ perlitic steels) and especially for nickel steels tough at subzero temperatures.*

**Table 5.24 Welding consumables and auxiliary materials for copper and copper alloys**

Quality grade	Testing and approval related to		Materials also covered by the approval	
	Designation	Material No.	Designation	Material No.
CuNi30Fe	CuNi30Mn1Fe	2.0882	CuNi5Fe CuNi10Fe1Mn CuNi20Fe	2.0872 2.0878
CuNi30Mn	CuNi 30 Mn 1 Fe	2.0882	CuNi5Fe CuNi10Fe1Mn CuNi20Fe	2.0872 2.0878
SCU1(1)	CU1(5)	-	-	-
SCU2(2)	CU2(5)	-	CU1(1)	-
SCU3(3)	CU3(5)	-	CU1(1) CU2(2)	-
SCU4(4)	CU4(5)	-	CU1(1) CU2(1) CU3(1)	- - -
<p>(1) <i>e. g. Al-bronze or Mn-bronze</i></p> <p>(2) <i>e. g. Al-bronze or Ni-Mn-bronze</i></p> <p>(3) <i>e. g. Al-bronze, Ni-Al-bronze or Mn-Al-bronze</i></p> <p>(4) <i>e. g. Mn-Al-bronze</i></p> <p>(5) <i>Cast copper alloys (for propeller manufacture) in accordance with TL's Rules for Materials or other comparable alloys with the appropriate strength properties.</i></p>				

**1.2** Welding consumables and auxiliary materials for welding of nickel and nickel alloys, for joining of different materials by welding and for welding of nickel steels tough at subzero temperatures are classified according to their chemical composition (type of alloy) and mechanical properties (mechanical and tensile strength) into the quality grades shown in Table 5.26. The testing and approval of a base material in the left-hand columns of Table 5.26 encompasses the material(s) in the right-hand columns. Suitability for welding of the nickel steels tough at subzero temperatures in low-temperature applications is indicated separately in the approval certificate; see G.

## 2. Testing of the Weld Metal

**2.1** For testing the deposited weld metal, the test pieces described in the standards (e.g. EN ISO 14172, EN ISO 15792-1 and EN ISO 6847 (DIN 32525)) shall be prepared according to the provisions of B.2. The provisions of the standards with regard to the base

materials to be used, including, where applicable, the buffering of the side walls of the weld, and to the welding parameters shall be complied with.

**2.2** The chemical composition of the deposited weld metal shall be determined and certified in a manner analogous to the provisions of B.2.2, taking into account the provisions of the standards. The results of the analysis shall not exceed the limits specified in the standards or by the manufacturer, the narrower tolerances being applicable in each case.

**2.3** Depending on the nature of the welding consumables and auxiliary materials (and according to the welding process), the test specimens shall be taken from the weld metal test pieces in accordance with the standards and the provisions of B.2.3.

**2.4** The mechanical properties must meet the requirements stated in Table 5.27. For welding of nickel steels tough at subzero temperatures, the notch impact

energy requirements stated in G.2.1 and G.2.2 apply. The provisions of A.7.6 and B.2.4 apply in analogous manner to the performance of the tests and any retests that may be necessary.

**2.5** TL may require other tests to be performed or stipulate other values for the required properties if they are more appropriate to the character of the welding consumables and auxiliary materials or are necessitated by the intended use of the material.

### 3. Testing on Welded Joints

**3.1** Depending on the nature of the welding consumables and auxiliary materials (and on the welding process concerned), the tests are to be performed on butt-weld test pieces in a manner analogous to B.3.

**3.2** The butt-weld test pieces shall be welded in accordance with B.3.2 taking into account the provisions of the above-mentioned standards (see 2.1). Wherever

possible, the base materials shall be the materials to be welded in the future application; in any case, however, materials of adequate strength must be used.

**3.3** Unless otherwise stipulated, the test specimens prescribed in B.3.3 for the various types of welding consumables and auxiliary materials (and, where applicable, the various welding processes) shall be taken from the butt-weld test pieces.

**3.4** The mechanical properties must meet the requirements stated in 2.4 and Table 5.27, with the exception of the proof stresses. TL may stipulate other values for the required properties; (see 2.4).

### 4. Annual Repeat Tests

The annual repeat test specified in A.3.1 shall entail the preparation and testing of a weld metal test piece in accordance with 2. TL may require more extensive repeat tests (see A.3.2, A.7.4 and A.7.5).

**Table 5.25 Required properties of welded joints**

Quality grade	Minimum 0,2% proof stress	Tensile strength	Minimum elongation
	[N/mm <sup>2</sup> ]	[N/mm <sup>2</sup> ]	[%]
CuNi 30 Fe	120	360-490	30
CuNi 30 Mn	120	360-490	30
SCU1	175	370 min.	20
SCU2	195	410 min.	18
SCU3	245	500 min.	16
SCU4	275	550 min.	18

Table 5.26 Welding consumables and auxiliary material for nickel and nickel alloys

Quality grade	Testing and approval relating to		Materials also covered by the approval	
	Designation	Material No.	Designation	Material No.
NiTi3 (2.4156)	Ni99,6	2.4060	Ni99,2 Ni99,6 LCNi99,6 LCNi99 And joints different non-ferrous metal alloys and with steels	2.4066 2.4056 2.4061 2.4068
NiTi4 (2.4155)	Ni99,6	2.4060	As for NiTi3	
NiCr19Nb (2.4648)	NiCr15Fe	2.4816	NiCr15 Fe LC-NiCr15 Fe NiCr20 Ti NiCr20 TiAl NiCr23 Fe And welded joints between different nickel alloys (except for NiCu) and with steels, welded joints in nickel steels tough at subzero temperatures	2.4816 2.4817 2.4951 2.4952 2.4851
NiCr20Nb (2.4806)	NiCr15Fe	2.4816	As for NiCr19Nb	
NiCr16FeMn (2.4620)	NiCr15Fe	2.4816	As for NiCr19Nb	
NiCr20Mo9Nb (2.4621)	NiCr22Mo9Nb	2.4856	NiCr21Mo NiCr22Mo6Cu NiCr22Mo7Cu NiCr21Mo6Cu Nickel steels tough at subzero temperatures	2.4858 2.4618 2.4619 2.4641
NiCr21Mo9Nb (2.4831)	NiCr22Mo9Nb	2.4856	As for NiCr20Mo9Nb	
NiCu30Mn (2.4366)	NiCu30Fe	2.4360	Joints with dissimilar materials, namely with unalloyed structural steels to EN 10025-1 and boiler steels to EN 10028-2	
NiCu30MnTi (2.4377)	NiCu30Fe	2.4360		

Table 5.27 Required properties of the nickel and nickel alloys (1)

Quality grade	Proof stresses		Tensile strength	Elongation
	$R_{p0,2}$ [N/mm <sup>2</sup> ] min	$R_{p1,0}$ [N/mm <sup>2</sup> ] min	$R_m$ [N/mm <sup>2</sup> ] min	$A_5$ [%] min
NiTi3 NiTi4	200	220	410	25
NiCr19Nb NiCr20Nb	360	380	600	
NiCr16FeMn	360	380	600	
NiCr20Mo9Nb NiCr21Mo9Nb	420	440	700	
NiCu30Mn NiCu30MnTi	200	220	460	
<b>(1)</b> The notch impact energy stated in 2.4 and, where applicable, G.2.1 and G.2.2.				



**SECTION 6****OVERWELDABLE SHOP PRIMERS**

<b>A.</b>	<b>GENERAL</b> .....	<b>6- 2</b>
<b>B.</b>	<b>APPROVAL TESTING OF SHOP PRIMERS</b> .....	<b>6- 2</b>
	1. Base Material	
	2. Filler Metal	
	3. Type and Dimension of Test Samples	
	4. Operational Procedures	
	5. Test Requirements	
	6. Re-Tests	
<b>C.</b>	<b>CERTIFICATION</b> .....	<b>6- 3</b>
<b>D.</b>	<b>PERIODICAL CONTROL TESTS</b> .....	<b>6- 4</b>

**A. General**

1. Shop primers applied to plates and sections to be welded are to be submitted to tests to verify their suitability for welding in respect of their tendency towards porosity in fillet welds.

2. The requirements of this rule apply to the procedure for approval and periodical control tests of over weldable shop primers. The approval is intended to be limited to the following welding processes:

- Manual metal arc welding
- Automatic gravity welding semiautomatic bare wire or flux cored arc welding.

The acceptance of primers for use with welding processes in addition to those above will be specially considered in connection with the approval of the welding procedure at the user's works.

3. The application for the approval is to be sent to **TL** by the primer Manufacturer or authorised supplier.

4. The following information and supporting documentation, as applicable, are to be submitted:

- Manufacturer,
- Trade name,
- Components of the primer, type of diluent and mixture ratio,
- Instructions (preparation of surfaces, method of application, drying time, recommended dry coat thicknesses, etc.)
- Specified resistance to marine atmosphere,
- Documentation relevant to previous tests and approvals.

**B Approval Testing of Shop Primers**

Approval tests are generally intended to verify the suitability of primers to obtain welds whose defects are within the usual tolerance limits. Primer samples for approval are to be taken from a sufficiently representative quantity of primer. Sampling procedures are to be to the Surveyor's satisfaction. Tests may be carried out at the Manufacturer's workshop, at the user's workshop or in an adequately equipped and staffed laboratory chosen in agreement with **TL**. Welding machines, welding procedures normally employed in shipyards and certified welders are to be used for the tests. The primer is to be applied and measured on the test pieces in compliance with the Manufacturer's specification. Thickness measurements are to be made using proper and calibrated equipment. Thickness measurements of the primer applied to the samples, welding and fracture tests are to be performed in the presence of the Surveyor.

**1. Base Material**

Normal strength hull steels or equivalent grades are to be used for the test specimens.

**2. Filler Metal**

**2.1** Approved filler metals are to be used.

**2.2** Basic covered electrodes are to be used for manual metal arc welding while acid or rutile electrodes are to be used for gravity welding. Filler metal for tests is chosen at the discretion of **TL** among those usually employed in shipbuilding.

**3. Type and Dimension of Test Samples**

**3.1** Test samples consist of double fillet welded T-joints formed by plates of the following dimensions:

- **300mm x 120mm x 15mm** for manual welding and semiautomatic bare wire and flux cored arc welding with gas shielding
- **700mm x 120mm x 15mm** for automatic gravity welding.

### 3.2 Number of samples required

Different commercial brands of filler metals are to be used for the tests as follows:

- a) 4 electrodes for manual welding,
- b) 1 bare wire for semiautomatic welding
- c) 2 cored wires for semiautomatic flux cored arc welding
- d) 2 electrodes for gravity welding, at least one of which is to be high efficiency.

For each brand above in (a), (b) and (c), two samples are required to be welded, one in horizontal position and one in vertical position, using electrodes of diameter 4 mm and wire with diameter 1,2 mm.

For each brand in d. one sample is required to be welded in horizontal position using electrodes with diameter 5 mm.

## 4. Operational Procedures

The primer thickness (measure made on dry coat) of the test samples is to be at least 30% greater than the maximum foreseen in normal use. The pieces are to be tack welded such as to form a T with adherent contact between the surfaces. On one side of the T sample a fillet weld of leg size 9 mm is to be deposited. The test fillet is to be deposited on the other side in the horizontal and vertical position as specified in B.1.4.2 with one bead having dimensions not exceeding 7x7 mm (Figure 6.1). Following visual examination, two auxiliary beads are to be welded along the edges of the test fillet so as to provoke fracture of its throat. After having previously removed the first fillet, the sample is to be fractured by suitable means aiming at closing the angle of the T so as to induce a tensile stress at the root of the weld.

## 5. Test Requirements

Visual examination is to be carried out consisting of checking the external and fractured surface to determine weld penetration and presence of wormholes,

pores and other defects. Possible defects located within 10 mm from the ends of the weld are disregarded. Lack of penetration having total length not exceeding 1/4 of the weld length is accepted. Wormholes and pores having diameter not exceeding 3 mm are generally acceptable where the total area of porosity is not higher than 5% of the fracture section area.

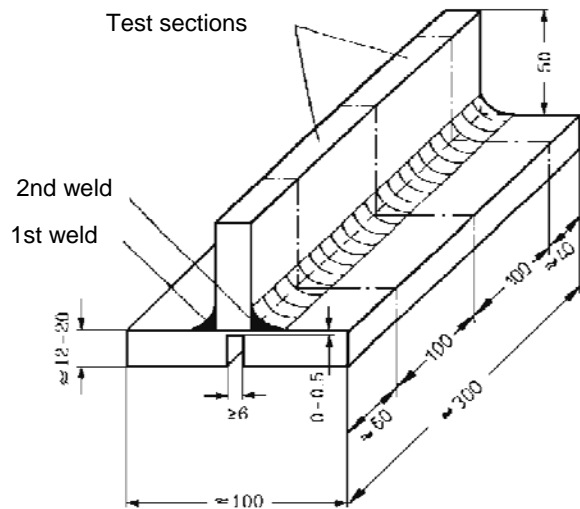

Figure 6.1 Double fillet weld production test piece

## 6. Re-Tests

Where a maximum of two samples for each manual and semiautomatic continuous wire welding process and a maximum of one sample for the gravity welding process give negative results, re-tests on two samples for each of those which originally failed are admitted. Both the samples of each re-test are to provide satisfactory results. Failing this, the primer is not approved.

## C. Certification

Subject to the satisfactory outcome of the required checks and tests, TL will issue to the Manufacturer or supplier concerned the approval certificate for the primer authorizing its use on surfaces of rolled steel product to be welded.

**D. Periodical Control Tests**

The approval has three-year validity and may be renewed subject to the satisfactory outcome of the periodical tests below. The samples required, of the T type like those for approval tests, are to be welded with at least the following filler metal:

- a) 2 electrodes for manual welding
- b) 1 bare wire for semiautomatic welding
- c) 1 cored wire for semiautomatic flux cored arc welding
- d) 1 electrode for gravity welding.

For each electrode in (a) above, two samples are required to be welded, one in horizontal position and one in vertical position.

For the other materials in (b), (c) and (d), one sample is required to be welded in horizontal position. For sampling and test procedures, materials to be employed, test requirements and re-tests, where applicable, the provisions relevant to initial type approval apply. Re-tests, in duplicate, are accepted only where a maximum of one sample for each welding process gives negative results. Failing this, the approval of the primer is not confirmed. Subject to the satisfactory outcome of the required check sand tests, a new approval certificate is issued with three year validity.

## SECTION 7

### GENERAL DESIGN PRINCIPLES

<b>A.</b>	<b>GENERAL</b> .....	7- 2
	1. Scope	
	2. Supplementary Rules	
<b>B.</b>	<b>INFORMATION CONTAINED IN MANUFACTURING DOCUMENTS</b> .....	7- 2
	1. Joint/Weld Shapes, Symbols	
	2. Information on Fabrication	
	3. Requirements for Welded Joints, Inspections	
<b>C.</b>	<b>MATERIALS, WELDABILITY</b> .....	7- 3
	1. Weldability, Processing	
	2. Material-Related Characteristics	
	3. Clad Plates	
	4. Pairs of Materials, Corrosion	
<b>D.</b>	<b>DESIGN DETAILS</b> .....	7- 3
	1. Accessibility, Workmanship and Fitness for Inspection	
	2. Location and Configuration of Welded Joints	
	3. Local Clustering of Welds, Minimum Spacing	
	4. Cut-Outs, Welding Apertures	
	5. Local Reinforcements, Plate Doubling	
	6. Stress Flow, Transitions	
	7. Double-T (cruciform) Joints, Stress in the Thickness Direction	
	8. Welding of Cold-Formed Sections	
	9. Other Design Measures	
<b>E.</b>	<b>DIMENSIONING OF WELDED JOINTS</b> .....	7- 5
	1. Dimensioning, Design Calculations	
	2. Minimum Thicknesses of Fillet Welds	
	3. Machining Allowance	

## A. General

### 1. Scope

These Rules contain universal principles applicable to the designing and dimensioning of welded joints, and to the information contained in the manufacturing documents.

### 2. Supplementary Rules

The designing and dimensioning of welded joints in the various ranges of application is additionally governed by the component-specific requirements stated in the Section 12 to 16 and in the respective Rules for Construction of **TL**.

## B. Information Contained in Manufacturing Documents

### 1. Joint / Weld Shapes, Symbols

**1.1** The depiction of welded joints and also the shapes of joints and welds shall conform to the standards (e.g. EN ISO 17659, ISO 2553, ISO 9692-1 or TS). They shall be identified in the manufacturing documents (drawings, etc.) in an unambiguous manner, e.g. by means of the standard symbols.

**1.2** Non-standard weld shapes or symbols shall be illustrated and, where applicable, explained in detail in the manufacturing documents (drawings, welding schedules or specifications). They must be approved by **TL** (e.g. in conjunction with the inspection of drawings or a welding procedure test).

**1.3** A weld shape appropriate to, and adequately dimensioned or well designed for the nature (static or dynamic) and magnitude of the forces to be transmitted shall be chosen. Where necessary, documentary proof of the design calculations shall be submitted (see the supplementary rules mentioned in A.2.).

### 2. Information on Fabrication

**2.1** The manufacturing documents to be submitted

for approval shall contain information on fabrication insofar as is relevant to the quality of the welded joints and necessary for inspection by **TL**. Besides the materials and weld shapes, this comprises the following information:

- Method of weld preparation (mechanical, thermal, etc.),
- Welding process, welding positions,
- Welding consumables and auxiliary materials,
- Preheating and, where applicable, heat input during welding,
- Weld build-up and number of passes,
- Welding sequence (in special cases),
- Grooving of root (method),
- Post-weld (heat) treatments, if any,
- Number and location of any production specimens to be welded at the same time (where stipulated).

With regard to the information on the requirements applicable to the welded joints and their inspection, see 3.

**2.2** If the preparation and execution of the welds (in conjunction with approved welding procedures, welding consumables and auxiliary materials) conform to normal welding and shipbuilding practice as well as to these Rules and the recognized standards, **TL** may waive the requirement that they be specially illustrated or indicated in the manufacturing documents.

### 3. Requirements for Welded Joints, Inspections

**3.1** The manufacturing documents (e.g. drawings, welding or inspection schedules) to be submitted for approval shall also indicate the quality requirements for the welded joints. Depending on the range of application, this may be done by means of the weld factor

(Section 13 and 14), or by means of the weld quality grade (see Section 12, I., Table 12.9) or the evaluation category according to ISO 5817 or ISO 10042 or TS EN ISO 5817. The tests (testing methods and scope of testing) to be used to verify the stipulated weld quality shall also be indicated.

**3.2** The requirements to be stated also include the leak-tightness to gases and liquids or the corrosion resistance to particular media.

**3.3** With regard to the welding procedure and production tests, see Section 4 and the application see Section 12 to 16, with regard to non-destructive testing, see Section 10 and the application Sections 12 to 16.

## **C. Materials, Weldability**

### **1. Weldability, Processing**

Only materials of proven weldability may be used for welded structures. Any conditions linked to the approval of the materials or to the welding procedure tests which impose restrictions on processing and the material manufacturer's recommendations shall be allowed for when designing the welded joint. With regard to the processing and use of TM steels, special TL recommendations are to be taken into account.

### **2. Material-Related Characteristics**

Material-related characteristics, such as the (inferior) strength of rolled products in the thickness direction (see D.7.2), the softening of hardened aluminium alloys when welded, or the different degrees of thermal expansion of the various materials, shall be allowed for when designing and dimensioning the components and welded joints.

### **3. Clad Plates**

Clad plates where the efficiency of the bond between the supporting and cladding material has been proved by materials testing (see Chapter 2, Material, Section 3. G) may generally be treated as solid plates (up to medium plate thicknesses with mostly fillet welds).

## **4. Pairs of Materials, Corrosion**

Where pairs of different materials are exposed to seawater or other electrolytes, e.g. welded joints between unalloyed (hull) structural steels and stainless steels, attention shall be paid to the increased tendency towards corrosion due to the differences in electrochemical potential. Where possible, these welded joints should be located at points where there is less danger of corrosion, or special corrosion protection should be provided (e.g. coating or cathodic protection).

## **D. Design Details**

### **1. Accessibility, Workmanship and Fitness for Inspection**

**1.1** Welded joints shall be planned at the design stage to ensure that they are readily accessible during fabrication and can be executed in the optimum welding position and welding sequence.

**1.2** Welded joints and welding sequences shall be designed to minimize residual weld stresses and avoid excessive deformation. Welded joints should therefore not be over-dimensioned.

**1.3** Welded joints shall be designed to ensure that the proposed weld type and quality (e.g. complete root fusion in the case of single- and double-bevel butt welds) can be satisfactorily achieved under the given fabricating conditions. Failing this, provision shall be made for welds which are easy to execute and their (possibly inferior) load-bearing capacity shall be allowed for when dimensioning the welds.

**1.4** Severely stressed welded joints, which are therefore normally subject to compulsory inspection, shall be designed to facilitate application of the most appropriate inspection technique (radiography, ultrasonic or surface crack inspection, possibly in combination) so that tests offering reliable results can be carried out.

## 2. Location and Configuration of Welded Joints

**2.1** In areas of high stress concentrations resulting from the design - and especially in cases of dynamic loading -, welded joints should be avoided as far as possible or designed in such a way as to provide a generally smooth stress profile without a significant additional notch effect originating from the welding operation. (Chapter 1, Hull, Section 3, D.)

**2.2** Intersecting butt welds in load-bearing walls of steam boilers and pressure vessels shall be avoided. The longitudinal seams of pipes shall be offset relative to one another at the pipe joints by at least 50 mm.

Intersecting butt welds in hull structures are allowed; if possible, however, the first (e.g. longitudinal) welded joint shall be completed and cleanly finished at the ends before the second (e.g. transverse) joint is made.

## 3. Local Clustering of Welds, Minimum Spacing

**3.1** The local clustering of welds and insufficient distances between welded joints are to be avoided (see also Section 12, G.4). Welds shall not be over-dimensioned. The thickness of fillet welds shall not exceed 0.7 times the thickness of the thinner of the two parts to be joined.

**3.2** Adjacent butt welds should be separated from each other by a distance of at least  $50 \text{ mm} + 4 \times \text{plate thickness}$ . Fillet welds should be separated from each other and from butt welds by a distance of at least  $30 \text{ mm} + 3 \times \text{plate thickness}$ . The width of interchangeable sections (strips) of plate should, however, be at least 300 mm or ten times the plate thickness, whichever is the greater. See also Section 12, G.4.1.

## 4. Cut-Outs, Welding Apertures

**4.1** Adequately sized cut-outs (welding apertures) shall be provided when, for instance, stiffeners are applied to platings before the butt joints in the plating are welded. See also Section 12, G.5. The welding apertures shall be rounded with a minimum radius of 25 mm or  $2 \times \text{plate thickness}$ , whichever is the greater.

**4.2** In special cases, e.g. when welding components subject to severe dynamic stresses, instead of providing welding apertures in the area of the butt welds it may be advisable to make a double-bevel weld preparation on the component to be attached to the plating, to weld up to this from both sides and to machine out the resulting root defect in the butt weld from the opposite side (of the plating).

## 5. Local Reinforcements, Plate Doubling

**5.1** Where platings (including girder plates and tube or vessel walls) are subjected locally to increased stresses, thicker plates should be used wherever possible in preference to plate doublings. Bearing bushes, hubs, etc. shall invariably take the form of thicker plates, forgings or the like welded into the plating.

**5.2** Where doubling plates cannot be avoided, their thickness should not exceed twice the plating thickness and their width should not exceed 30 times the doubling plate thickness. With regard to welding of doubling plates and especially the ends of such plates, see Section 12, G.6. With regard to the design and welding of doubling plates as cut-out reinforcements in pressure vessels, see the Rules for Construction.

## 6. Stress Flow, Transitions

**6.1** All welded joints on supporting members shall be designed to provide as smooth a stress profile as possible with no major internal or external notches, no discontinuities in rigidity and no obstructions to expansion.

**6.2** To this end, components with different dimensions shall be adjusted to one another by means of gradual transitions (e.g. by bevelling the edges of the thicker component). Steel castings and forgings must therefore be provided with integrally cast or forged welding flanges. See Section 12, G.3 and the Rules for Construction.

## 7. Double-T (cruciform) Joints, Stress in the Thickness Direction

**7.1** Where, in the case of double-T (cruciform) joints, rolled products are stressed in the thickness



direction due to the residual weld stresses or the applied loads, suitable measures shall be taken in the design of the structures to prevent lamellar tearing (stratified fractures). Such measures include the use of suitable weld shapes with a minimum weld volume and a welding sequence designed to reduce the shrinkage stresses in the thickness direction.

**7.2** Where there are very severe stresses in the thickness direction (e.g. due to bulky single- or double-bevel butt welds), materials with enhanced characteristics in the direction at right angles to the surface of the product are to be used (see Chapter 2, Material, Section 3).

## **8. Welding of Cold-Formed Sections**

Welding of cold-formed sections of (hull) structural steels is permissible provided that the conditions stated in Section 12, G.8. are complied with. In special cases, post-weld heat treatment may be necessary or documentary proof of adequate toughness after welding may be demanded.

## **9. Other Design Measures**

**9.1** Welds should not be located in channels of sections owing to the danger of the presence of segregations and the residual stresses in these areas arising from the rolling process.

**9.2** Welded joints (fillet weld joints) in areas where the risk of corrosion cannot be excluded shall be continuously executed around components, cutouts, etc. to provide a seal.

**9.3** If heat treatment is carried out on components with sealed-off hollow spaces necessitated by the design, such as occur in the case of cut-out reinforcements (doublings), mounted loose flanges or suspender rings, a means of venting, e.g. a drilled hole, shall be provided.

## **E. Dimensioning of Welded Joints**

### **1. Dimensioning, Design Calculations**

**1.1** Dimensioning shall be carried out in accordance with the Rules for Construction with reference to the shape and quality of the weld in question and the type (static or dynamic) and level of stress. The dimensions of the weld (if required) must be apparent from the manufacturing documents to be submitted for approval. In the case of fillet welds, an indication shall also be given as to whether the dimensional data refer to the throat thickness of the weld "a" or to the leg length "z".

**1.2** Where required by TL (e.g. in the Rules for Construction or as part of the examination of the drawings), mathematical proof (a general stress analysis and/or proof of fatigue strength) shall be furnished that the weld is adequately dimensioned.

### **2. Minimum Thicknesses of Fillet Welds**

Fillet weld throat thicknesses shall conform to TL Rules or the results of design calculations. Throat thicknesses not established according to the Rules or design calculations shall be executed, as a minimum requirement, with a throat thickness of

$$a = 0,5 \times \text{plate thickness,}$$

the smaller plate thickness being the ruling dimension.

Unless otherwise agreed (e.g. for the fully-mechanised welding of smaller plate thicknesses in appropriate clamping jigs), the minimum fillet weld throat thickness shall be

$$a_{\min} = \sqrt{\frac{t_1 + t_2}{3}} \quad [\text{mm}] \quad \text{but not less than 3 mm.}$$

$t_1$  = Smaller (e.g. the web) plate thickness in [mm],

$t_2$  = Larger (e.g. the flange) plate thickness in [mm].

A smaller minimum fillet weld throat thickness (e.g. 2,5 mm.) may be agreed to if its faultless execution is demonstrated by means of a welding procedure test.

### 3. Machining Allowance

Adequate machining allowances (thicker welds) shall be provided for the subsequent machining of welds to

ensure that the prescribed minimum weld thicknesses are achieved on completion of the work. This particularly applies to welds with only partial penetration, as occasionally occur for instance in machinery components, in which case provision shall be made for machining correspondingly deeper joints from the outset. In the case of the notch-free grinding of the welds, which is employed in the case of particular weld quality requirements, correspondingly thicker welds shall be deposited.

**SECTION 8****EXECUTION OF WELDS**

<b>A.</b>	<b>GENERAL .....</b>	<b>8- 2</b>
	1. Scope, Supplementary Provisions	
	2. Welding Shop Requirements	
	3. Materials, Marking	
	4. Welding Consumables and Auxiliary Materials	
	5. Overweldable Shop Primers	
	6. Manufacturing Documents, Company Standards	
<b>B.</b>	<b>WELD PREPARATION, ASSEMBLY .....</b>	<b>8- 3</b>
	1. Weld Preparation	
	2. Weld Shapes, Root Openings (Air Gaps)	
	3. Alignment of Components	
	4. Tack Welds and Preparations for Welding	
<b>C.</b>	<b>WEATHER PROTECTION, PREHEATING.....</b>	<b>8- 3</b>
<b>D.</b>	<b>WELDING POSITIONS, WELDING SEQUENCE .....</b>	<b>8- 4</b>
<b>E.</b>	<b>PERFORMANCE OF WELDING.....</b>	<b>8- 4</b>
<b>F.</b>	<b>STRAIGHTENING, TOLERANCES .....</b>	<b>8- 5</b>
<b>G.</b>	<b>POST-WELD-TREATMENT OF WELDS .....</b>	<b>8- 5</b>

## A. General

### 1. Scope, Supplementary Provisions

1.1 This section contains universal rules applicable to the performance of welding work, extending from the weld preparation to the completion of the welded joints including any finishing operations. For heat treatment see Section 9; for testing of the welded joints, Sections 10 and 11.

1.2 The performance of the welding work is additionally governed by the application of Section 12-16. The relevant provisions of the respective Rules for Construction shall also be complied with.

### 2. Welding Shop Requirements

2.1 All workshops wishing to carry out welding work shall comply with the welding shop requirements stipulated in Sections 2, 3 and 4 and, where necessary, Section 10.

2.2 Workshops shall maintain up-to-date records of this compliance and shall submit them to the Surveyor at his request. If necessary (e.g. in the case of a prolonged interruption to the work, see Section 2, A.4.2 and Section 3, E.), TL may reinspect the workshop.

### 3. Materials, Marking

3.1 Welding may only be performed on materials whose identity and weldability under the given fabricating conditions can be unequivocally established by reference to markings, certificates, etc.

3.2 In case of doubt, the identity and weldability of the materials shall be verified before welding commences.

### 4. Welding Consumables and Auxiliary Materials

4.1 Only welding consumables and auxiliary materials tested in accordance with Section 5, approved by TL and of a quality grade appropriate to the base material to be welded may be used. The various quality grades corresponding to the different hull

structural steels shall be as shown in Table 12.1 in Section 12.

4.2 Welding consumables and auxiliary materials for particular materials or those intended for special welding processes which have been approved on the basis of a (preliminary) welding procedure test may be used only for the range of application specified in the relevant approval certificate. Any special conditions or rules associated with such applications shall be complied with.

4.3 Welding consumables and auxiliary materials may only be used with the electrode diameters covered by the tests and for the approved welding positions. The manufacturer's instructions and recommendations for use (e.g. the type of current and polarity used) shall be complied with.

4.4 If necessary, welding consumables and auxiliary materials are to be baked, prior to use, in accordance with the manufacturer's instructions (keeping to the specified maximum baking time) and are to be kept dry at the place of work (in heated containers or similar).

### 5. Overweldable Shop Primers

5.1 Overweldable shop primers which are applied to plates, sections, etc. prior to welding and are not removed must be tested and approved in accordance with Section 6.

5.2 Welding shops shall ensure by suitable checks (especially on the thickness of the coating) and production tests carried out at random during the course of normal fabrication that the quality of the welded joints is not impaired to an unacceptable degree.

### 6. Manufacturing Documents, Company Standards

6.1 Welds shall be executed in accordance with approved drawings, welding schedules or company standards recognized by TL. Exceptions to this rule are subject to TL's consent in each individual case.

6.2 Compliance with the manufacturing documents is the responsibility of the welding shop.

**B. Weld Preparation, Assembly****1. Weld Preparation**

1.1 Weld preparation may be carried out by thermal cutting or machining. Seam edges (groove faces) prepared by thermal cutting shall be finished by machining (e.g. grinding) if a detrimental effect on the welded joint as a result of the cutting operation cannot be ruled out. Welding edges of steel castings and forgings shall always be ground as a minimum requirement; roll scale or casting skin is to be removed.

1.2 Groove faces must be free from impurities and defects liable to impair the quality of the welded joint, e.g. laps, coarse grooves made by the cutting torch and slag. Prior to welding, the welding edges shall be inspected for defects, e.g. cracks, inclusions, blowholes or pores, using non-destructive testing methods if necessary.

**2. Weld Shapes, Root Openings (Air Gaps)**

2.1 When preparing and assembling components, care shall be taken to ensure compliance with the weld shapes and root openings (air gaps) specified in the manufacturing documents. With single- and double-bevel butt welds in particular, care shall be taken to make an adequate root opening to achieve sufficient root penetration.

2.2 The root opening shall not exceed twice the specified gap. If the size of the gap permitted by this rule is exceeded locally over a limited area, the gap may be reduced by build-up welding of the side walls, subject to the consent of the Surveyor. With fillet welds, the "a" dimension shall be increased accordingly, or a single- or double-bevel weld shall be made if the air gap is large. Inserts and wires may not be used as fillers.

**3. Alignment of Components**

3.1 Components which are to be united by butt welding are to be aligned as accurately as possible. Sections welded to plating shall be left unwelded at the ends for this purpose. Special attention shall be paid to the alignment of (abutting) girders which are interrupted by transverse members. If necessary, such alignment shall be facilitated by drilling check holes in the

transverse member which are subsequently closed by welding.

3.2 The permissible edge alignment error depends on the nature, importance and loading of the component concerned and is dealt with in the various sections of these Rules. Where special loading conditions or other requirements relevant to the application necessitate a limitation of the edge alignment error, the allowable error shall be stated in the manufacturing documents.

**4. Tack Welds and Preparations for Welding**

4.1 Tack welds should be used as sparingly as possible and should be made by trained personnel. Where their quality does not meet the requirements applicable to the welded joint, they are to be carefully removed before the permanent weld is made.

4.2 Clamping plates, temporary ties and aligning pins shall be made from the same material as the base material or from a material of similar composition and should not be used more than necessary. Any damage caused during their removal shall be competently repaired.

4.3 With mechanized welding processes or when arc striking and end crater defects in butt welds have to be avoided, run-in and run-off plates shall be provided in continuation of the line of the weld.

4.4 Components must be clean and dry in the area of the welds. Any scale, rust, cutting slag, grease, paint (except for approved overweldable shop primers), moisture or dirt shall be carefully removed before welding.

**C. Weather Protection, Preheating**

1. The areas to be welded shall be adequately protected against climatic influences such as wind, damp and cold and shall be preheated where necessary.

2. The need for and degree of preheating is determined by various factors, such as chemical composition, plate thickness, two- or three-dimensional heat dissipation, ambient and work piece temperatures, or

heat input during welding (energy applied per unit length of weld). Details are given in Section 9, Section 12 to 16.

3. Preheating shall be applied uniformly throughout the thickness of the plate or component over a width of four times the plate thickness, but not less than 100 mm. Preheating may be as necessary for tack and auxiliary welds as for fabricating welds.

#### D. Welding Positions, Welding Sequence

1. Welding should be performed in the optimum welding position; positional welding is to be limited to the indispensable minimum. The welders employed on positional welding must be qualified for the welding positions concerned. With regard to welding in the vertical-down position, see Section 12, H.7.

2. The welding sequence shall be chosen to allow shrinkage to take place as freely as possible. Butt joints in areas of plating shall invariably be fully welded prior to attaching girders and stiffeners. TL may require an assembly procedure or welding sequence schedule to be drawn up in special cases.

#### E. Performance of Welding

1. The welding shop shall ensure that the specified welding parameters are adhered to and that the welding work is expertly performed.

2. Components shall not be subjected to any appreciable movements or vibration during welding.

Parts to be assembled while suspended from cranes or floating shall be clamped prior to tack-welding of the joints in such a way that no relative movement of the parts is possible. Components which have not been fully welded and which are to be handled or turned must have welded joints of adequate strength.

3. Cracked tack welds may not be welded over, but are to be machined out. In multi-pass welding, the slag of the previous run shall be completely removed before the next pass is laid down. Pores, visible slag

inclusions and other welding defects and cracks may not be welded over, but are to be machined out and repaired.

4. Welds must have sufficient penetration and must display a clean, regular surface with "gentle" transitions to the base material. Excessive weld reinforcements and undercuts or notches affecting the edges of plates and cutouts are to be avoided.

5. Butt-welded joints must display full fusion over the entire cross-section, unless otherwise specified in a particular case. For this purpose, the root shall normally be grooved and capped. Following a successful welding procedure test confirmed by TL, single-side welds, e.g. using ceramic backings, may be regarded as equivalent to butt welds executed from both sides. Other joints welded on one side only, e.g. using permanent backings, are subject to TL's approval when scrutinizing the relevant drawings.

6. Single- and double-bevel butt welds may be made according to the design specification either with grooved roots as full penetration welded joints or with a permitted incomplete penetration at the root or defined, unwelded root face subject to the appropriate reduction factors (see Section 12, G.10.2.). The type of weld is to be specified in the drawings in each case and must have received TL's approval when scrutinizing the drawings.

With fillet welds, particular attention shall be paid to good root penetration. The penetration must extend to at least the immediate vicinity of the theoretical root point. The ideal fillet weld section is that of an equal-sided flat-faced weld with smooth transitions to the base material. At the ends of web plates, at cutouts and at welding apertures, the fillet welds shall be formed round the web to form a seal.

7. Major cases of faulty workmanship or defects in the material may only be repaired with the Surveyor's agreement. Minor surface defects shall be removed by shallow grinding. Defects which penetrate more deeply into the material (e.g. cracks, or damage caused by the removal of auxiliary erection equipment) shall be cleanly machined out and where necessary repair-welded with an adequate heat input.

8. Repair (so-called production welds) on steel castings and forgings shall only be made with the consent of the Surveyor. If their volume is considerable, sketches and descriptions of the repair work shall be submitted to **TL**'s head office for approval, together with details of the analysis of the base material, the welding process and the welding consumables and auxiliary materials. **TL** may require stress relief heat treatment or, in special cases, further heat treatment of the components after welding.

9. When working and welding higher-strength hull structural steels, high-strength (quenched and tempered) fine-grained structural steels, austenitic stainless steels and aluminium alloys, attention should be paid to the relevant information and instructions in Section 12 to 16. For this work, **TL** may require an appropriate welding specification to be submitted.

#### **F. Straightening, Tolerances**

1. Straightening operations (whether thermal or mechanical) shall not impair the quality of the materials and welded joints. **TL** may require verification of the suitability of the straightening method (e.g. by means of a welding procedure test). This especially applies to high-strength (quenched and tempered) fine grain structural steels.

2. Unless specific tolerances are stated in Section 12 to 16 or in the manufacturing documents, the dimensional tolerances for welded structures shall be as specified in the standards (EN/ISO 13920, ISO 5817 or ISO 10042 or TS EN ISO 5817). The degree of fineness and the evaluation category shall be stipulated in the manufacturing documents. **TL** may specify other (tighter) tolerances where this is necessary for reasons of strength and/or operational safety.

#### **G. Post-Weld-Treatment of Welds**

1. If it is intended to carry out post-weld-treatment of the welds, e.g. to improve the surface finish in the case of dynamic loading, such treatment shall not impair the characteristics (mechanical properties) of the welded joints. **TL** may demand documentary proof thereof.

2. For post-weld heat treatment, see Section 9; for the post-treatment of surfaces for non-destructive testing, see Section 10, F.1.

**SECTION 9****HEAT TREATMENT**

<b>A.</b>	<b>SCOPE</b> .....	<b>9- 2</b>
<b>B.</b>	<b>EQUIPMENT AND APPLIANCES FOR HEAT TREATMENT</b> .....	<b>9- 2</b>
	1. Equipment and Appliances for Preheating	
	2. Fixed Heat-Treatment Equipment (Heat-Treatment Furnaces)	
	3. Other Heat-Treatment Equipment	
<b>C.</b>	<b>PRINCIPLES RELATING TO HEAT TREATMENT</b> .....	<b>9- 2</b>
<b>D.</b>	<b>WEATHER PROTECTION, PREHEATING, HEAT INPUT DURING WELDING</b> .....	<b>9- 3</b>
	1. Weather Protection, Welding at Low Temperatures	
	2. Preheating for the Welding of Ferritic Steels	
	3. Monitoring Interpass Temperatures	
	4. Welding with Controlled Heat Input per Unit Length of Weld	
	5. Preheating and Heat Input During the Welding of Other Steels or Metallic Materials	
<b>E.</b>	<b>POST-WELD HEAT TREATMENT</b> .....	<b>9- 8</b>



**A. Scope**

1. These Rules apply to preheating for, and heat input during welding and to post-weld heat treatment of welded components where required. For preheating of hull structural steels, see also Section 12, H.4. and H.5.

2. Requirements relating to the heat treatment of hot or cold formed welded components (e.g. spherical or dished ends, T-pieces and elbows) are stipulated in TL's Chapter 2, Materials.

**B. Equipment and Appliances for Heat Treatment****1. Equipment and Appliances for Preheating**

Preheating may be carried out either in heat treatment equipment or by means of mobile heating appliances, e.g. gas burners or electrical induction or resistance heating appliances as applicable (resistance mats). A condition of their use is that the prescribed preheating and interpass temperatures must be capable of being kept constant and monitored throughout the welding operation.

The temperature may be monitored by means of suitable appliances or aids, e.g. contact thermometers, temperature sensors or temperature-sensitive crayons.

**2. Fixed Heat-Treatment Equipment (Heat-Treatment Furnaces)**

2.1 The fixed heat-treatment facilities (heat-treatment furnaces) must be of suitable size for the particular components and structures in question and be fitted with an appropriate temperature control facility. The furnaces must ensure that the particular heat treatment temperatures stipulated can be guaranteed and that the temperature is evenly and accurately controlled. (DIN 17052-1, quality grade C)

2.2 An adequate number of temperature recorders shall be provided, subject to a minimum of 2 to each furnace. The temperature variation over the period shall be established and recorded. The temperature control device and the temperature and time recording instruments used shall be checked at regular intervals

(at least once a year) and documentary proof of the inspection results submitted to TL on request.

**3. Other Heat-Treatment Equipment**

The primary requirements are given in B.1., but depend upon the particular requirements relating to the component or structure. The type and method of the heat treatment in question is subject to TL's consent.

If no heat treatment furnace of sufficient size is available for the heat treatment of components, heat treatment may be carried out in mobile facilities (transportable furnaces) or in equipment which has been specially designed for the purpose, subject to TL's consent. Such equipment shall comply with the requirements stated in 2.1 and 2.2 with regard to function, temperature control and temperature recording and shall be presented to TL for inspection before being used. Care shall be taken to ensure that there is adequate insulation of the components or welds needing heat treatment. Unacceptable temperature gradients in the component shall be avoided.

**C. Principles Relating to Heat Treatment**

1. Heat treatment, temperature measurements and recording shall be performed by competent personnel.

2. The type, temperature and duration of the heat treatment process, in addition to the rates of heating and cooling are determined by the material, the thickness of the material, the production process and the nature of the component or structure. See also the provisions of EN 1011 Parts 1 to 4 and in the regulations given in Section 12 to 16. The information and recommendations provided by the manufacturer of the materials and welding consumables shall be observed.

3. Details of the pre- and post-weld heat treatment of a component or structure shall be included in the production documents submitted for inspection by TL. Where the manufacturer's welding procedure specifications (WPS) are used, these shall contain the necessary information relating to preheating, heat input during welding and post-weld heat treatment.

4. The whole of the component is normally subject to post-weld heat treatment. The heat treatment of part or sections of welds or the heat treatment of partial areas, especially pressurized components, require TL's consent in each individual case. A specification relating to this shall be submitted to TL for examination.

5. Where welded joints are to be produced between different materials, in the case of complex welded components (e.g. LNG/LPG process pressure vessels and gas tanks), components which have high levels of cold forming (more than 3 %) or extensive structural and repair welds to castings, the need for, type and extent of any heat treatment shall be agreed with TL.

6. Parts shall be properly prepared for heat treatment in due order. Flange facings and sealings must be adequately protected against scaling. Precautions shall be taken to protect against component distortions; components and structures shall be positioned accordingly. Unacceptable temperature gradients during the heat treatment process and during heating and cooling shall be avoided.

#### D. Weather Protection, Preheating, Heat Input during Welding

##### 1. Weather Protection, Welding at Low Temperatures

1.1 The area in which welding work is performed is to be sheltered from wind, damp and cold, particularly if out of doors. Where gas-shielded arc welding is carried out, special attention is to be paid to ensuring adequate protection against draughts. When working in the open under unfavourable weather conditions it is advisable to dry welding edges by heating.

1.2 At ambient temperatures below + 5 °C, additional measures shall be taken, such as shielding of components, extensive preliminary heating and pre-heating, especially when welding with a relatively low heat input (energy input per unit length of weld), e.g. when laying down thin fillet welds or in the case of rapid heat dissipation, e.g. when welding thick-walled components. Wherever possible, no welding should be

performed at ambient temperatures below - 10 °C.

##### 2. Preheating for the Welding of Ferritic Steels

2.1 The need for preheating of ferritic steels and the preheating temperature depend on a number of factors. Chief among these are:

- The chemical composition of the base material (carbon equivalent) and the weld metal,
- The thickness of the work piece and the type of weld joint (two or three dimensional heat flow),
- The welding process and the welding parameters (energy input per unit length of weld),
- The shrinkage and transformation stresses,
- The temperature dependence of the mechanical properties of the weld metal and the heat-affected zone,
- The diffusible hydrogen content of the weld metal.

2.2 The operating temperature to be maintained (minimum preheating temperature and maximum interpass temperature) for (hull) structural steels may be determined in accordance with EN 1011-2. Guide values for the preheating temperature are contained in Figures 9.1 and 9.2 shown below for two different energy inputs per unit length of weld (1) and hydrogen contents HD (2) of the weld metal, together with the various carbon equivalents CET (3).

##### Note :

Table 9.1 below gives guide values for the carbon equivalents CET (3) of some of the standard grades of steel. Basis were the information of the steel manufacturers. In case of doubt CET has to calculate by the actual analysis.

2.3 Table 9.2 contains guide values for preheating high temperature Mo or CrMo alloy steels (used for steam boiler) in accordance with TL's Rules for Materials; see EN 1011-2.

**2.4** Table 9.3 contains guide values for preheating nickel steels tough at sub-zero temperatures in accordance with TL's Rules for Materials. For details of this and also particulars relating to the use of austenitic or nickel-based welding consumables, see EN 1011-2.

**2.5** Depending on the complexity of the component, the welding process applied, the level of the residual stresses in the component and the (low) ambient temperature, the preheating temperatures shall be increased or the boundary wall thicknesses reduced as appropriate. For the effect of the various factors on the preheating temperature level, see Table 9.4.

**2.6** If the temperature of the work piece is lower than the minimum operating temperature calculated on the basis of the above data, preheating is called for. Various methods are available:

- Continuous heating prior to and during welding,
- Alternate heating and welding,
- Heating only prior to the start of welding, if the heat input during welding is sufficient to maintain the minimum operating temperature.

**(1)** Energy input per unit length of weld:

$$E = \frac{U [\text{volts}] \cdot I [\text{Amps}] \cdot \text{welding time} [\text{min}] \cdot 6}{\text{length of weld} [\text{mm}] \cdot 100} \left[ \frac{\text{kJ}}{\text{mm}} \right]$$

**(2)** HD 5 = max. 5 ml diffusible hydrogen per 100 g of weld metal.

HD 15 = max. 15 ml diffusible hydrogen per 100 g of weld metal.

**(3)** Carbon equivalent :

$$CET = C + \frac{Mn + Mo}{10} + \frac{Cr + Cu}{20} + \frac{Ni}{40} \left[ \% \text{ in weight} \right]$$

The above formula for calculating the carbon equivalent CET in accordance with EN 1011-2 can be applied to steels which have yield strengths ranging from 300 to 1000 MPa and to the following chemical composition: 0.05- 0.32 %C, max. 0.8% Si, 0.5-1.9% Mn, max. 0.75% Mo, max. 1.5 % Cr, max. 0.7 % Cu, max. 2.5 % Ni, max. 0.12 % Ti, max. 0.18 % V, max. 0.005 % B, max. 0.06 %Nb.

**Table 9.1 Guide values for the carbon equivalent CET**

Steel grades	CET (% in weight)	
	Average value (1)	Maximum value (1)
TL-A	0.27	0.28
TL-E	0.26	0.27
TL-D36	0.33	0.34
TL-E36TM	0.27	0.28
TL-D40	0.27	0.28
TL-E40TM	0.24	0.25
S275NL	0.25	0.27
S460NL	0.34	0.36
S460ML(TM)	0.27	0.28
S690QL	0.26	0.38
S890QL	0.38	0.41
C22	0.26	0.29
34CrMo4	0.49	0.55
GS20Mn5	0.34	0.41
<b>(1)</b>	For product thicknesses up to 50 mm.	

The heating method may be chosen at will, provided that it does not harm the material by localized overheating or cause a nuisance by making the welding area contaminated.

**2.7** Preheating is always necessary for tack and auxiliary welds whenever preheating is needed for the rest of the welding. Possible exceptions to this rule are tack and auxiliary welds where it can be guaranteed that subsequent welds are remelted the heat affected zone, for instance tacks for submerged arc welds.

**2.8** Irrespective of the information given above, preheating is always necessary when making major auxiliary erection welds, e.g. when welding on handling lugs and when welding very large wall thicknesses and also thick-walled castings and forgings.

**2.9** Preheating shall be applied uniformly throughout the thickness of the plate or component over a distance of four times the plate thickness, minimum of 100 mm, on both sides of the weld. Localized overheating is to be avoided. Preheating with gas burners should be performed with a gentle, though not sooty, flame in order to prevent dirt being deposited in the area of the weld. For details on the recording of the preheating temperature, see EN ISO 13916.

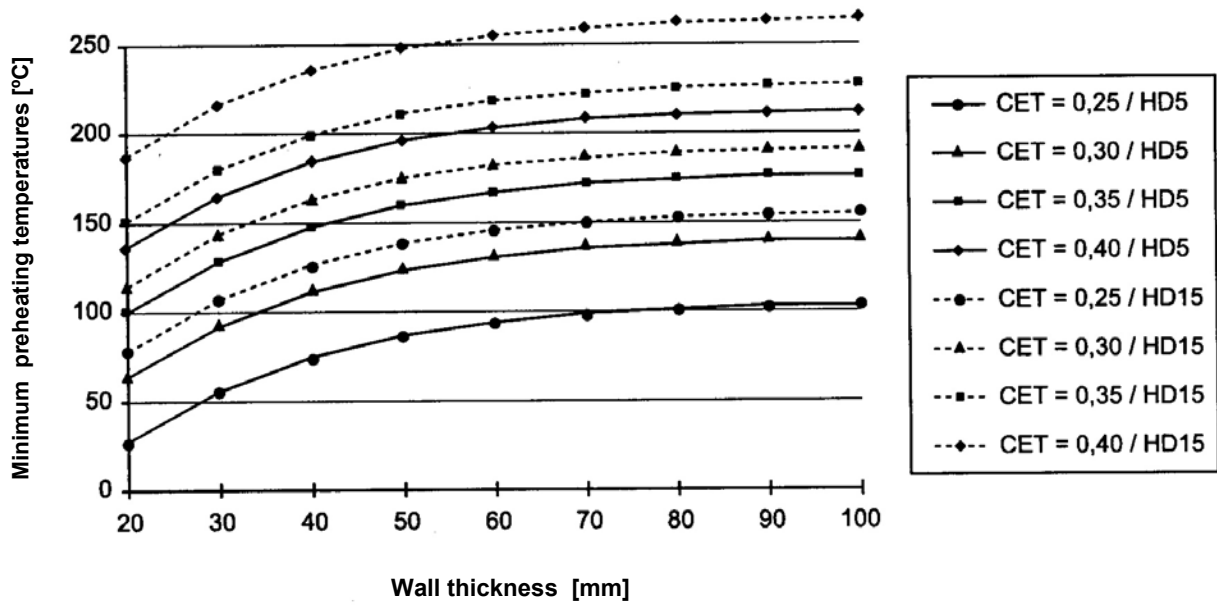

Figure 9.1 Minimum preheating temperatures (operating temperatures) applicable to welding processes with a relatively low heat input (energy input per unit length (1)  $E \approx 0.5$  kJ/mm) as a function of the carbon equivalent CET(3) of the base material and the hydrogen content of the weld metal

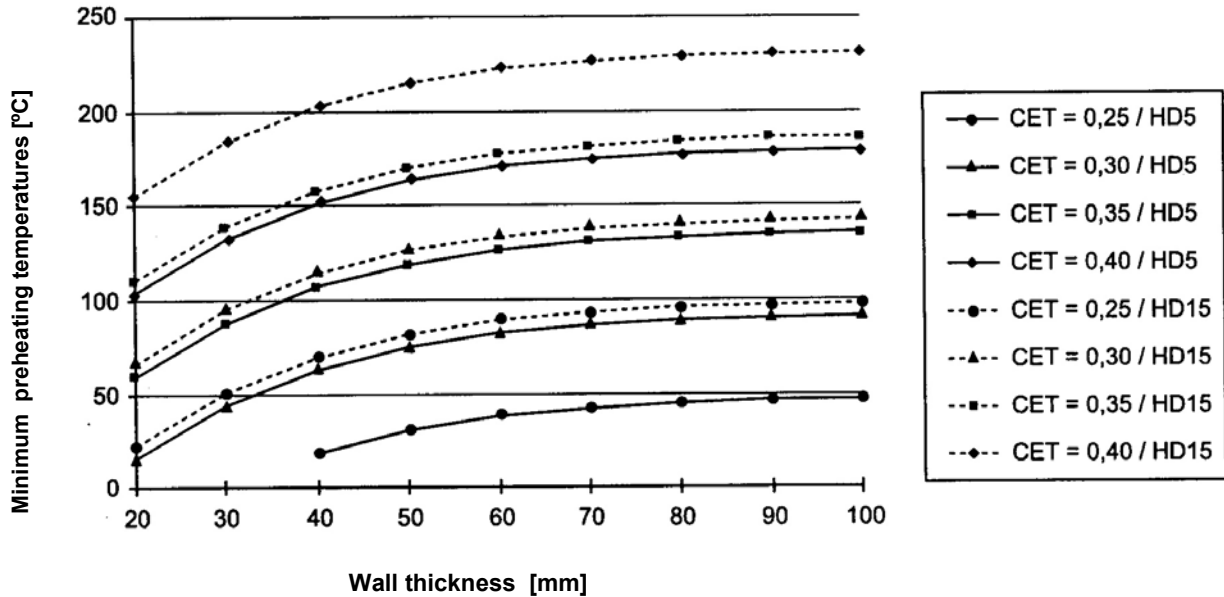

Figure 9.2 Minimum preheating temperatures (operating temperatures) applicable to welding processes with a relatively high heat input (energy input per unit length (1)  $E \approx 3.5$  kJ/mm) as a function of the carbon equivalent CET (3) of the base material and the hydrogen content of the weld metal

Table 9.2 Guide values for preheating high-temperature steels (used for steam boiler)

Category in accordance with DIN-FACHBERICHT CEN ISO/TR 15608	Steel grade	Thickness [mm]	Minimum preheating temperature [°C] given an H <sub>2</sub> content of the weld metal of		
			≤ 5 ml/100 g.	> 5 - ≤ 10ml/100g	> 15ml/100g
1.2	16Mo3	≤ 15	20	20	100
		> 15 - ≤ 30	20	75	100
		>30	75	100	Not permitted
5.1	13CrMo4-5	≤ 15	20	100	150
		> 15	100	150	Not permitted
5.2	10CrMo9-10	≤ 15	75	150	200
	11CrMo9-10	> 15	100	200	Not permitted

Table 9.3 Guide values for preheating nickel steels tough at sub-zero temperatures

Category in accordance with DIN-FACHBERICHT CEN ISO/TR 15608	Steel grade	Thickness [mm]	Minimum preheating temperature [°C] given an H <sub>2</sub> content of the weld metal of	
			≤ 5 ml/100 g	> 5 - ≤ 10ml /100g
7.2	12Ni14 (%3,5 Ni)	>10	100	150
7.3	12Ni19 (%5 Ni)	>10	100	Not permitted
	X8Ni9 (%9 Ni)	>10	100	Not permitted
	X7Ni9 (%9 Ni)	> 10	100	Not permitted

Table 9.4 Effects of the various factors on the level of preheating

Shift in the preheating temperature to lower values	Factors influencing preheating	Shift in the preheating temperature to higher values
Low alloying element content	Chemical composition of the base material (hardenability), e.g. expressed by the carbon equivalent	Higher alloying element content
Thin	Thickness of the work piece or component (heat dissipation, rigidity, residual stress condition)	Thick
Butt joints (2 planes), thick (multiple run) welds	Type of joint, weld shape and dimensions, heat input, heat dissipation	T-joint (3 planes) thin (single-run) welds
High	Ambient or work piece temperature (heat dissipation)	Low
High	Heat input (energy input per unit length of weld) during welding	Low
Low	Hydrogen content of the weld metal (type and rebaking of the welding consumables and auxiliary materials)	High

**2.10** To prevent cold cracks in higher-strength and high-strength (quenched and tempered) steels, thick-walled components or components of complex design, it is advisable to use measures which give the hydrogen introduced into the weld metal during welding sufficient time to escape. The following methods are well established:

- Maintenance of a specific minimum preheating and interpass temperature throughout the welding operation,
- Delayed cooling after welding,
- Holding at approx. 250°C prior to cooling (hydrogen-reducing heat treatment) or
- Heat treatment immediately after welding (without cooling in between)

**2.11** Where hull structural steels or fine-grained structural steels have undergone thermo-mechanical processing (TM steels), the need for and degree of preheating shall be decided on separately on the basis of the carbon equivalent and the results of the approval or welding procedure tests as applicable. Drying of the areas to be welded by heating may be sufficient.

### 3. Monitoring Interpass Temperatures

The guide values contained in Table 9.5 for the interpass temperatures relating to the various steels shall not be significantly exceeded.

### 4. Welding With Controlled Heat Input Per Unit Length of Weld

In addition to controlling the preheating and interpass temperature, the heat input per unit length of weld shall be controlled during welding, especially in the case of weldable, high-strength (quenched and tempered) fine-grained structural steels. The heat input per unit length of weld shall not fall below or exceed the values indicated by the steel manufacturer or those used in the welding procedure tests and specified in the welding procedure specifications (WPS) by any significant amount.

### 5. Preheating and Heat Input During the Welding of Other Steels or Metallic Materials

5.1 Preheating is not normally required for austenitic materials. Preheating may be necessary for austenitic-ferritic materials. A maximum permitted interpass temperature which is normally between 150°C and 180°C shall be complied with in order to prevent hot cracks.

**Table 9.5 Guide values for the maximum interpass temperature during welding**

Category in accordance with DIN-FACHBERICH T CEN ISO/TR 15608	Steel grades	Maximum interpass temperature [°C]
1.1	Normal-strength hull structural steels and comparable structural steels	250
1.2	Higher-strength structural steels and comparable structural steels	250
1.2	High-temperature, low Mo alloy steels	250
2	Normalised or thermo-mechanically processed fine-grained steels with yield strengths of > 360 N/mm <sup>2</sup>	250
3	Quenched and tempered or precipitation-hardened (excluding stainless) steels with yield strengths of > 360 N/mm <sup>2</sup>	250
5	Steels with a max. Cr content of 10 % and a max. Mo content of 1,2 %	350
7	Nickel alloy steels with a max. Ni content of 10 %	250

**5.2** Ferritic and stainless martensitic steels shall be adequately preheated and welded using controlled heat input per unit length of weld. Guide values for the preheating and interpass temperatures are prescribed in EN 1011-3.

**5.3** Preheating is not normally required for welding aluminium alloys, but should not exceed 50°C. A maximum permitted interpass temperature of 100°C to 120°C shall be complied with in order to prevent undesirable phase dispersion. EN 1011-4 contains guide values for the preheating temperature to be applied and the interpass temperature.

## E. Post-Weld Heat Treatment

**1.** Welded components shall be subjected to post-weld heat treatment where this is prescribed in Sections 12 to 16. Post-weld heat treatment is generally used for ferritic steels, in which case stress relief heat treatment or tempering is normally sufficient. Where consideration also has to be paid to other codes of practice in the manufacture of certain components or structures (e.g. TRD 201 relating to the construction of steam boilers, see Section 13, A.2.2), the provisions relating to post-weld heat treatment contained in these codes of practice shall also be complied with.

### Note:

*The need for and type of post-weld heat treatment is determined by various factors, the most important of which are given below:*

- *Material characteristics and dimensions (wall thicknesses)*
- *Minimum anticipated operating temperature (design temperature)*

- *Type of operating and background environment (e.g. risk of corrosion)*
- *Build-up of welds to inhibit elongation and shrinkage*
- *Risk of distortion during subsequent machining*

**2.** If stress relief heat treatment after welding is insufficient and more extensive heat treatment is required (e.g. normalising or quenching and tempering), the method of heat treatment shall be specially established in accordance with the material specification and the conditions of use and subject to agreement by **TL**. This shall also apply in analogous manner to materials and material combinations other than those dealt with here and also to other methods of stress-relief.

**3.** The stress relief heat treatment shall be carried out by means of slow, even heating of the components to the prescribed temperature ranges (Table 9.6 contains guide values), holding in these ranges for two minutes per mm of wall thickness (but not less than 30 minutes), slow cooling to 400 °C in the furnace or heat treatment appliance, and then complete cooling in still air. For thick-walled components, the holding time need not be more than 150 minutes.

**4.** If there is a risk of the components being distorted during cooling, the heat treatment may, within certain limits, be carried out at a lower temperature with an increased holding time. The required temperatures and holding times shall be agreed with **TL**.

**5.** Joints between ferritic and austenitic steels (weld metal) must not, as a general rule, be subjected to heat treatment due to the risk of carbon diffusion, except where the welds are made using nickel-base filler materials

**Table 9.6 Heat treatment temperatures for stress-relief heat treatment of welded joints using similar filler metals**

Category in accordance with DIN-FACHBERICH T CEN ISO/TR 15608	Steel grades	Examples of appropriate steels in accordance with TL's Rules or the standards (1)	Heat treatment temperature [°C]
1.1	Normal-strength hull structural steels and comparable structural steels, grade of steel forgings and castings	TL Grade A-E	550-600
1.2	Higher-strength hull structural steels and comparable structural steels, grades of steel forgings and castings	TL Grade A36-E36	530-580
1.2	High-temperature, low Mo alloy steels	16Mo3	550-620
2	Normalised or thermo-mechanically processed fine-grained steels with yield strengths > 360 N/mm <sup>2</sup>	TL Grade A39 - E39 S460 TM	530-600
3	Quenched and tempered fine-grained structural steels with yield strengths > 360 N/mm <sup>2</sup>	S690 QL	530-580
5			
5.1	Steels with a max. Cr content of 10 %, max Mo content of 1,2 %	13CrMo4-5	630-680
5.2		10CrMo9-10,11CrMo9-10	670-720
7			
7.1	Nickel steels with a maximum Ni content of 10 %	13MnNi6-3 (%0,5 Ni)	530-560
7.2		12Ni14 (%3,5 Ni)	530-560
7.3		12Ni19 (%5 Ni)	530-560
7.3		X8Ni9(%9Ni)	(2)
7.3		X7Ni9 (%9 Ni)	(2)
<p>(1) Steel grades not listed here are to be classed together with comparable grades.</p> <p>(2) Heat treatment should be avoided.</p>			



## SECTION 10

### NON-DESTRUCTIVE TESTING OF WELDS

<b>A.</b>	<b>GENERAL</b> .....	<b>10- 3</b>
	1. Scope	
	2. Standards and Other Codes of Practice	
	3. Requirements Applicable to the Inspection Department	
<b>B.</b>	<b>TEST METHODS, APPLIANCES AND TEST MEDIA</b> .....	<b>10- 3</b>
	1. Test Methods	
	2. Test Appliances and Media	
<b>C.</b>	<b>INSPECTION PERSONNEL, SUPERVISORS</b> .....	<b>10- 4</b>
	1. Inspection Personnel (Inspectors)	
	2. Inspection Supervisors	
<b>D.</b>	<b>INSPECTION SCHEDULE, INSPECTION REPORTS</b> .....	<b>10- 4</b>
	1. Inspection Schedule	
	2. Inspection Reports	
<b>E.</b>	<b>TIMING OF INSPECTION, WAITING TIMES</b> .....	<b>10- 5</b>
<b>F.</b>	<b>PREPARATION AND PERFORMANCE OF TESTS</b> .....	<b>10- 6</b>
	1. Preparation of Areas to be Tested	
	2. Performance of Tests	
<b>G.</b>	<b>EVALUATION OF TEST RESULTS</b> .....	<b>10- 6</b>
	1. Identification of Test Findings	
	2. Evaluation Criteria	
	3. Evaluation, Rating	
<b>H.</b>	<b>EXTENSION OF THE SCOPE OF INSPECTION</b> .....	<b>10- 8</b>
<b>I.</b>	<b>REPAIRS, RE-INSPECTION</b> .....	<b>10- 8</b>
	1. Repairs	
	2. Re-inspection	
<b>J.</b>	<b>VISUAL INSPECTION</b> .....	<b>10- 8</b>
<b>K.</b>	<b>RADIOGRAPHIC INSPECTION</b> .....	<b>10- 9</b>
	1. Radiation Sources, Appliances	
	2. Films, Intensifying Screens	
	3. Radiographic Parameters	
	4. Film Processing, Density, Image Quality	
	5. Viewing Conditions, Evaluation, Inspection Report	
<b>L.</b>	<b>ULTRASONIC INSPECTION</b> .....	<b>10-11</b>
	1. Test Appliances and Accessories	
	2. Calibration, Sensitivity Setting	
	3. Surface Preparation, Coupling	
	4. Scanning Directions, Angle of Incidence	
	5. Registration Level, Evaluation of Echo Indications	
	6. Inspection Reports	

<b>M.</b>	<b>MAGNETIC PARTICLE INSPECTION</b> .....	<b>10-16</b>
	1. Test Appliances and Media	
	2. Magnetization Method and Field Strength	
	3. Preparation of Testing Surfaces, Direction and Duration of Magnetization	
	4. Evaluation, Inspection Reports	
<b>N.</b>	<b>LIQUID PENETRANT INSPECTION</b> .....	<b>10-17</b>
	1. Test Media	
	2. Preparation of Testing Surfaces, Performance of Inspection	
	3. Evaluation, Inspection Reports	

**A. General****1. Scope**

**1.1** These Rules apply to the performance of the non-destructive tests of welded joints according to the methods and scopes prescribed in Section 12 to 16 the various fields of application. See also Section 1, A.1. and A.2.

**1.2** They also apply to the performance of all non-destructive weld tests which are stipulated in other regulations, rules or technical instructions issued by TL and for which no specific details are given therein.

**2. Standards and Other Codes of Practice (1)**

**2.1.** IACS Rec 17 and the standards etc. mentioned in the following paragraphs are an integral part of these Rules and shall also be complied with when performing the nondestructive weld tests. Where the standards contradict these Rules, the latter shall take precedence.

**2.2.** The performance of tests according to other, comparable codes of practice requires the prior consent of TL. For this purpose, the relevant codes of practice shall be submitted to TL together with the other inspection documents (See D 1.1) for examination and approval.

**3. Requirements Applicable to the Inspection Department**

The works' inspection department shall be as independent and free from the influence of the fabrication department as it is necessary to ensure that the inspection and the evaluation of the inspection results are carried out objectively. This applies in analogous manner to outside inspection bodies.

**B. Test Methods, Appliances and Test Media****1. Test Methods**

**1.1** The choice of the test method to be used in each case is determined among other things by the component or weld shape, the material and the defects to be demonstrated (type and position). See Section 12 to 16.

**1.2** Unless otherwise stated in the individual application-specific of Section 12 to 16 the following basic requirements apply:

- Up to a wall or weld thickness of approx. 30 mm, radiographic inspection is the preferred method; for larger thicknesses, ultrasonic inspection is to be used as the primary test method.
- For wall or weld thicknesses of approx. 10 mm and above, either radiographic or ultrasonic inspections may be performed, in consultation with TL.
- For radiographic inspection, X-ray sources shall be used wherever possible. Gamma ray sources may only be used with TL's consent on the basis of an examination and recognition of the test method; see K.1.
- For magnetic materials, testing for surface cracks shall wherever possible be carried out by magnetic particle inspection; the use of liquid penetrant inspections for magnetic materials requires TL's consent in each individual case.

**1.3** The test method must be capable of reliably detecting the external and/or internal defects which may be present. Where necessary, this shall be achieved by using two or more test methods in combination. The particular test method(s) to be used shall be stated in the inspection schedule (see D.1.1).

**2. Test Appliances and Media**

**2.1** The test appliances and media used must conform to the state of the art and the relevant standards and must be in perfect, serviceable condition. The Society may require an inspection of the test appliances and/or media used.

**2.2** When making use of test equipment, test

---

**(1)** *Code: Regulations comprising globally recognised design requirements and conditions to be applied to design.*

appliances, etc. owned by other, outside testing bodies, the works shall ensure that the conditions stated in 2.1 are satisfied.

## C. Inspection Personnel, Supervisors

### 1. Inspection Personnel (Inspectors)

**1.1** The non-destructive weld tests may only be performed by persons trained in the use of the test method concerned and possessing adequate practical experience. **TL** shall be supplied with appropriate documentary proof of such training and experience, e.g. conforming to ISO 9712.

**1.2** Inspection of welds by ultrasonic means shall only be performed by inspectors holding a Level 2 certificate of accredited body (or equivalent) and having at least 2 years of proven practical testing experience who are recognized by **TL**.

**1.3** For such recognition, **TL** may require verification of the suitability of the ultrasonic inspection personnel and of the test appliances and the test method under practical conditions in the works. In exceptional cases and where necessary for a restricted field of use, **TL** may, following successful verification, also recognize inspectors who do not hold the certificates specified in 1.2.

**1.4** Application for such verification shall be made to **TL**'s Head Office, accompanied by the following information and documents:

- Documentary proof of the professional training of the inspection personnel and, where applicable, the inspection supervisors,
- A description of the test equipment (appliances, probes, etc.),
- A description of the test method (instrument setting, angles and scanning directions, instrument sensitivity, etc.),
- Method of determining the size of defects,

- Form of the inspection report.

After successful verification, recognition may be linked to authorization of the inspector for the independent performance of certain tests and inspections (materials weld shapes) under his personal responsibility. The decision lies with **TL**.

#### *Note:*

*The recognition and authorization of an inspector normally covers the inspection of normal butt and corner joints (e.g. the joints uniting deck stringers and sheer strakes) or approximately right-angled T-joints in hull structural steels and/or other comparable structural steels. For the performance of further (more difficult) tests (e.g. on other materials and/or on acute-angled tube connections and weld shapes of comparable complexity), the authorization shall be subject to special review and supplementation.*

### 2. Inspection Supervisors

**2.1** An appropriately qualified works inspection supervisor shall be available for scheduling and monitoring the performance of the non-destructive weld tests and evaluating the results. The name of the inspection supervisor shall be given to **TL**; proof of his qualifications (in conformity with standards Level III certificate from accredited body or for welding supervisor to ISO 14731 standard with additional NDT training) shall be submitted to **TL**.

**2.2** The inspection supervisor is responsible for ensuring that the non-destructive weld tests are competently and conscientiously carried out and recorded by suitable inspectors in accordance with these Rules, the relevant standards and the approved inspection schedule.

**2.3** When using the services of outside inspection bodies, the works shall ensure that the above conditions are satisfied and shall inform **TL** accordingly.

## D. Inspection Schedule, Inspection Reports

### 1. Inspection Schedule

**1.1** Unless already stated in the other manufacturing documents (drawings, parts lists, etc.) to be

submitted for approval, an inspection schedule for the non-destructive weld tests shall be drawn up, which must contain the following information:

- Components and welded joints to be tested,
- Scope and method of testing, areas to be tested, location of testing positions, see Section 12 to 16.
- Requirements applicable to the welded joints (for evaluation criteria, see Section 12 to 16.
- Testing standards and/or specifications, if it is intended to use standards or specifications different from those mentioned in these rules.

**1.2** The location of testing positions shall be subject to agreement between the welding shop and the TL's Surveyor, whereupon the inspection schedule shall be submitted to TL's Head Office for approval. TL reserves the right to make changes to this inspection schedule even after approval has been given and especially to change the location of the individual testing positions or to extend the scope of testing (see H.) if the production process and/or test results suggest this to be necessary.

## **2. Inspection Reports**

**2.1** Reports shall be prepared on all (initial and repeat) tests, and these shall be submitted to the Surveyor together with the other documentation (e.g. radiographs). The inspection reports must contain all the necessary details according to Sections K. to N. relating to the particular test method used, the position at which the test was performed and the results obtained.

### **Note:**

*Where the test results are to be recognized in place of the prescribed welder's repeat tests in accordance with Section 3, E.3, the inspection reports shall also state the names or identification numbers of the welders.*

**2.2** Repeat tests (following repairs) and their results shall be specially identified in the inspection reports; see I.2.2. The results and documents relating

to the initial test shall be submitted to TL's Surveyor along with the results and documents relating to the repeat tests and also specifically if the repair was arranged for in-house.

**2.3** Inspection reports shall be signed by the inspector and the test supervisor. Reports and documentation shall be kept for six years.

## **E. Timing of Inspection, Waiting Times**

**1.** Non-destructive testing of welds shall as a general rule, not to be carried out until all the welding operations on the component concerned have been completed. In special cases, e.g. in the case of thick-walled components at risk of cracking, it may be advisable to carry out non-destructive tests, e.g. for surface crack examinations, as an interim measure (in the course of the welding work).

**2.** Before using the test methods described in K. to N., a visual inspection of the welded joints shall be performed. Surface defects which restrict the ability of the tests to produce meaningful results or which may lead to misinterpretation of the results shall be remedied before any further tests are performed.

**3.** Components which are subjected to post-weld heat treatment (e.g. stress relief heat treatment) shall as a general rule be inspected after heat treatment. Inspection of the welds for welding defects before heat treatment as well is recommended. TL may take previous inspections into account when establishing the final scope of inspection. Details shall be agreed with TL on a case-by-case basis.

**4.** In the case of higher-strength and especially high-strength (e.g. quenched and tempered) structural steels where the possibility of delayed cracking (e.g. due to the presence of hydrogen in the weld metal) cannot be ruled out, the tests shall not be carried out earlier than 48 hours after completion of the welding work. TL may demand longer waiting times (e.g. 72 hours up to a maximum of 7 days) or repetition of the tests (at least on a random sampling basis) after an appropriate waiting time.

5. Repetition of non-destructive tests shall be allowed for or may be demanded if the components or welded joints have been subjected to abnormal stresses (e.g. while in transit or during trial loading or pressure testing) before being stressed in normal service. The type and scope of these tests shall be agreed with **TL** on a case-by-case basis.

## **F. Preparation and Performance of Tests**

### **1. Preparation of Areas to be Tested**

1.1 The areas to be tested (surfaces of welds and of adjacent parts of the work piece) must be sufficiently clean and smooth for the respective test method. Irregularities in the welded joint (see E.2) remains of auxiliary welds, welding spatter, fragments of slag, etc. and any protective coatings or preservatives must be removed before the tests if they are liable to prevent them from being performed properly.

1.2 In special cases, e.g. ultrasonic testing for transverse defects (see L.4.3), grinding of the seam and the surface of the work piece may be necessary.

### **2. Performance of Tests**

2.1 Non-destructive testing of welds shall be carried out in the manner described in Sections K. to N. The place and date of the tests shall be notified to the Society's Surveyor in good time. The Surveyor shall be given the opportunity to participate in or supervise the tests if he so wishes.

2.2 The individual positions (sections) to be tested shall be durably marked on the component or the welded joint in such a way that the test findings (e.g. weld defects requiring repair) can be unequivocally localized at any time up to the completion of all tests and, where applicable, repairs. If the dimensions are appropriately indicated (or a similar measure is used) in the drawings, inspection schedules and inspection reports, marking of the component may be dispensed with.

## **G. Evaluation of Test Results**

### **1. Identification of Test Findings**

In the case of radiographic testing and, where applicable, the methods of surface testing, the reference numbers and/or symbols conforming to ISO 6520-1 or, as applicable, in Table 10.1 (extract from the standard) may be used to identify (describe) test findings (e.g. welding defects). With regard to the description of defects in ultrasonic testing, see L.5.

### **2. Evaluation Criteria**

2.1 Unless otherwise specified for the respective components or welded joints in Section 12 to 16 the evaluation categories according to ISO 5817 may be used as evaluation criteria for steel and those according to ISO 10042 for aluminium alloys.

2.2 In the inspection schedules, testing instructions, etc. to be drawn up by the welding shop (see D.1.), the evaluation categories to be determined according to the type and level of stress or, where necessary, other individual evaluation characteristics shall be assigned to the individual components and welded joints. With regard to the evaluation of results of ultrasonic testing in conjunction with the stipulations in the above-mentioned standards (evaluation categories), see L.5.

2.3 **TL** may consent to the use of different evaluation criteria or criteria conforming to other standards, etc. if they are approximately comparable to those mentioned in 2.1 and are suited to the particular test method used. Details shall be agreed with **TL** on a case-by-case basis.

### **3. Evaluation, Rating**

3.1 The inspection results shall be evaluated by the testing department or body and/or the welding supervisory staff. The ultimate evaluation and the decision whether to leave defects in materials and welds as they are or to repair them is reserved for **TL**'s Surveyor.

3.2 The results may be rated according to Table 10.2 (in the case of radiographic inspection) or, in the case of ultrasonic testing or if a broader statistical

evaluation is not required, by "leave as is" or "satisfied" or, as the case may be, "to be repaired" or "not satisfied".

**Table 10.1 Symbols denoting defects (taken from ISO 6520-1)**

Reference No. / symbol conforming to the IIW X ray manual		Description (1)
100	E	Crack
101	Ea	Longitudinal crack
102	Eb	Transverse crack
104	Ec	End crater crack
2011	Aa	Pore
2015	Ab	Elongated cavity (Gas pocket)
2016	Ab	Worm hole
2024	K	Crater pipe (End crater cavity)
301	Ba	Slag inclusion
304	H	Metallic inclusion
4011	-	Lack of side-wall fusion
4012	-	Lack of inter-run fusion
4013	D	Lack of root fusion
402	D	Lack of penetration (Incomplete penetration)
5011	F	Undercut, continuous
5012	F	Undercut, intermittent
5013	-	Shrinkage groove, groove in the root (see 515)
502	-	Excessive weld reinforcement (butt weld)
503	-	Excessive convexity (fillet weld)
504	-	Excessive root reinforcement
507	-	Misalignment of edges
510	-	Burn-through
511	-	Incompletely filled groove
515	-	Root concavity (see 5013)
517	-	Poor restart
<b>(1)</b> For explanations and illustrations, see ISO 6520-1.		

**Table 10.2 Evaluation ratings**

Findings	Rating	Remarks
Weld free from detectable defects	1 = good	-
Minor defects such as isolated pores and small slag inclusions which do not reduce the strength or tightness of the welded joint	2 = serviceable	-
Avoidable defects such as small rows or clusters of pores, small slag lines, short root defects and minor lack of fusion	3 = leave as is	Repair not recommended for components subject to normal stresses. Short root defects and minor lack of fusion may be left only at non-critical points
Defects which must be avoided, e.g. coarse slag inclusions, accumulations of pores, generally all root defects and lack of fusion, and small isolated cracks	4 = to be repaired	Repair of defects required. Exceptions only for components without particular requirements on strength and tightness, but not at cracks.
Extensive major defects and cracks	5 = to be replaced	Replacement of the section of weld or of the entire welded joint required

## H. Extension of the Scope of Inspection

1. If it is not certain that a defect to be repaired ends within the tested section of the weld, the adjacent sections of the weld shall also be inspected.

2. If major defects are found during inspections at random, the scope of inspection shall be extended. Unless otherwise agreed, for each section of weld to be repaired two more of the same length shall be inspected.

3. In the case of ultrasonic testing, TL reserves the right to carry out control tests at random on the basis of the inspection reports compiled by the firm's inspector or to require control tests to be performed by a second, independent testing authority. If major differences from the results of the initial tests performed in the firm are found, the scope of the control tests may be extended.

## I. Repairs, Re-inspection

### 1. Repairs

1.1 Defects requiring repair on the basis of the evaluation shall be carefully grooved over a sufficient length (especially in the case of intersecting welds) and/or re-welded. Where a number of defects needing repair are located close together in a single section of weld, the entire section shall be machined out and re-welded.

1.2 Undercuts in need of repair, poor transitions to the surrounding material or other surface defects shall, where possible, be remedied by grinding out with smooth transitions to the surrounding material or, if they are too deep for this, they shall, with the Surveyor's consent, be ground out and repair-welded.

### 2. Re-inspection

2.1 Repaired welds shall be re-inspected. Where welds have been completely remade, retesting at least equal in scope to the initial inspection shall be performed at random in accordance with the Surveyor's instructions.

2.2 Re-inspections shall be specially indicated in the inspection reports and on the radiographs, e.g. by means of an "R" (= repair) next to the title of the film (see D.2.2).

## J. Visual Inspection

1. The surfaces and back sides of the welds shall undergo a complete visual inspection, with the aid of optical (magnifying) appliances where necessary, to check their external characteristics. The following characteristics shall be checked:

- Completeness,
- Dimensional accuracy,
- Compliance with the specified weld shape,
- Absence from inadmissible external defects.

2. The dimensional accuracy shall be checked with suitable measuring instruments on a random sampling basis. When measuring fillet weld throat thicknesses, measuring gauges which measure with sufficient accuracy in throats which are not an exact right angle shall be used where necessary.

3. When checking for the correct shape of weld and external defects, attention shall be paid to the following:

- Weld reinforcement or top bead depression,
- Weld edge angles (transitions to surrounding material),
- Misalignment of edges,
- Undercuts,
- Visible pores and slag inclusions
- Fused weld spatter,
- Arc strikes on the surface of the base material,



- Concave root surface and incomplete root fusion,
- Cracks,
- Unequal side lengths (in the case of fillet welds).

With regard to the limits of acceptability, see G.2. and Section 12 to 16. Repairing of visible cracks is mandatory.

## K. Radiographic Inspection

### 1. Radiation Sources, Appliances

1.1 Wherever possible, X-ray units shall be used as radiation sources for radiographic inspections. The radiation energy (tube voltage) shall lie within the energy limits specified in ISO 17636. Allowing for the differences in thickness of the component, the radiation energy (tube voltage) should be kept as low as possible within the permissible working range so as to obtain a high-contrast image.

1.2 Where justified in exceptional cases (e.g. by lack of accessibility), gamma ray sources - preferably Ir 192 or Se 75 - may be used as radiation sources, subject to TL's consent in each instance; see 4.4.

### 2. Films, Intensifying Screens

2.1 Class C5 films conforming to EN ISO 11699-1 or G III conforming to ISO 5579 may normally be used in shipbuilding for X-raying steel. Class C3 or C4 and GI or GII films, as applicable, are to be used for the radiographic inspection of aluminium alloys and when using gamma rays to inspect steel. The use of class C3 or C4 and GI or GII films, as applicable, is obligatory in steam boiler, pressure vessel and pipeline manufacture (pipe class I and II).

**Note:**

*Annex A provides a summary of the classification of the most popular X-ray films currently on the market. This summary does not claim to be exhaustive and manufacturers of other X-ray films are invited to make the classification of their products by independent inspection institutes public and*

*make the appropriate documents available to TL so that they can supplement the list.*

2.2 Front and rear 0,02 mm lead screens shall normally be used when radiographing steel. During radiography, the film and the screens must be kept in intimate contact in suitable cassettes, packs, etc. Radiographs may be made of aluminium alloys up to about 65 mm thick without the use of intensifying screens.

2.3 The use of salt intensifying screens and fluo-rometal screens is not allowed.

### 3. Radiographic Parameters

3.1 As a general rule, the radiographic parameters prescribed in ISO 17636 for test category A (general inspection procedure) shall be applied in shipbuilding and those for test category B (higher-sensitivity inspection procedure) shall be applied in steam boiler, pressure vessel and pipeline manufacture (pipe class I and II). In special cases TL may stipulate application of test category B in shipbuilding as well. For radiographic inspection using X-rays and a film length of 480 mm, the distance between the film and the focal point shall normally be 700 mm, and in any case not less than the length of the film.

3.2 If several films are used to inspect a seam (e.g. for circumferential radiographs), they shall overlap at the ends in such a way that the full pattern of the weld can be traced without interruption.

3.3 When inspecting pipes with an outside diameter  $\leq 90$  mm, elliptical radiographs may be made. Depending on the diameter and wall thickness of the pipe, two or more elliptical radiographs are to be made so that the full length of the weld (the entire circumference of the pipe) is shown in the area of the radiographs capable of evaluation.

3.4 For larger-diameter pipes, either double-wall radiographs or, if the pipe diameter permits, central or single-wall radiographs shall be made. Care shall be taken to ensure that the film is capable of evaluation at both its ends. The area capable of evaluation shall only be the section of the weld in which the rays delimiting the beam do not cover more than 1.1 times the weld

thickness that is radiographed with vertical irradiation.

The number of radiographs shall be determined accordingly.

**3.5** In order to determine the image quality to EN 462-3 standard, at least one image quality indicator to EN 462-1 (wire indicator) shall, for each radiograph, be laid on the side of the weld away from the film and facing the radiation source and shall be radiographed together with the weld. Should this be impossible, the image quality indicator may, with TL's consent and after the preparation of comparative radiographs designed to determine the changed index of image quality, be fixed to the work piece on the side close to the film (i.e. between the film and the weld). The film image must be marked with a corresponding identification ("N") to indicate that this arrangement was used, and appropriate mention must be made in the inspection report.

**3.6** Each film image must be clearly and unmistakably identified by lead figures or letters simultaneously irradiated and depicted on the film. This identification must be the same as that given in the inspection schedule and must enable any defects found to be readily located. The marking is to be located outside the weld area to be evaluated (the weld width plus at least 10 mm. on each side).

#### **4. Film Processing, Density, Image Quality**

**4.1** The films must be processed in properly equipped darkrooms in such a way as to avoid any blemishes which interfere with their evaluation (e.g. fogging, scratches, dark crescent-shaped marks due to kinks in the film, etc.).

The instructions and recommendations issued by the film and chemical manufacturers are to be followed. Premature interruption of the developing process and reduction with chemicals of over-exposed films is not allowed.

**4.2** The radiographic images must have a density (D) of at least 2,0 over the entire area for evaluation. The upper limit value depends on the brightness of the

film viewers available for the evaluation, but should not exceed 2,5 to max. 3,0. Wide differences in density within a single radiograph are to be avoided.

**4.3** The image quality shall be determined with an image quality indicator of the type prescribed in 3.5 and in accordance with EN 462-1. For category A inspection (see 3.1), image quality B is desirable for steel, with image quality A as the minimum requirement. In the case of aluminium alloys and test category B, image quality B must be attained. The criterion in each case is the smallest wire of the image quality indicator which is still visible in the area to be evaluated, the density being uniform.

**4.4** The works or the inspection department/ body must demonstrate on request by means of specimen radiographs that the required radiographic parameters and image quality can be attained.

#### **5. Viewing Conditions, Evaluation, Inspection Report**

**5.1** Viewers with a luminous density to EN 25580/ISO 5580 sufficient for the required film density shall be used for the examination and evaluation of radiographs. Stops must be fitted to enable the field of view to be adapted to the film size for, or capable of, evaluation. The brightness must be adjustable.

**5.2** The viewing and evaluation of radiographs shall take place in a dimly lit though not completely darkened room. Evaluation should only be performed after a sufficient period has been allowed for adaptation. Bright, dazzling areas within the field of view are to be screened. The use of magnifying glasses for the detection of fine details may be beneficial.

**5.3** The following information is to be given in the inspection report, together with explanatory sketches where necessary:

- Works number, component, inspection schedule number, inspection position(s),
- Material, welding process,
- Thickness of work piece or weld, as appropriate,

- Date and time of test (see E.3. and elsewhere),
- Radiation source and size of tube focus or emitter,
- Tube voltage or activity at time of inspection,
- Radiographic arrangement to ISO 17636, position of wire indicator,
- Type of film, nature and thickness of intensifying screens,
- Test category, image quality index and image quality class,
- Symbols denoting defects and assessment in accordance with G.

The inspection report must also indicate whether the information relates to an initial radiograph or to a follow-up inspection after repair work has been carried out (see D.2.1 and I.2.2).

**5.4** The initial evaluation shall be carried out by the welding supervisory staff and/or the works inspection department. Then the films (initial and follow-up radiographs, see D.2.1 and I.2.) shall be submitted to TL's Surveyor for evaluation together with the inspection reports (see G.3.1).

## L. Ultrasonic Inspection

### 1. Test Appliances and Accessories

**1.1** The test appliances, probes and other accessories (calibration and reference blocks for adjusting the sensitivity, reference scales, etc.) shall conform to the state of the art and the relevant standards (e.g. EN 12223, EN ISO 7963/ISO 2400, EN ISO 17640 or ISO 16810 or related TS standards).

**1.2** All possible echo heights within the range of instrument sensitivity used must be capable of being determined with the aid of an amplification control calibrated in dB and a suitable scale marking on the

display. The interval between the switching stages shall not exceed 2 dB. Instruments not equipped with a calibrated amplification control may not be used.

**1.3** Stepless controls must enable the ranges of adjustment available on the instrument to follow on from one another, as far as possible without any intervening gap. Within each individual range the time sweep must be continuously adjustable.

**1.4** With regard to the geometrical characteristics of the sound field, especially the incidence and squint angles, the testing frequency and the resolution, the probes must lie within the tolerances specified in the standards mentioned above. The incidence and squint angles shall not in either case deviate by more than 2° from the nominal value or from the centre line of the probe. The angle of incidence and the probe index (of angle beam probes) shall be verified.

## 2. Calibration, Sensitivity Setting

**2.1** The distance signal (time sweep) may be calibrated in projection distances "a", shortened projection distances "a'" or sonic distances "s" as desired or, if necessary, depth positions "b". Unless otherwise agreed, calibration in shortened projection distances "a'" is preferred for weld inspections, or in sonic distances "s" for parts of complex shape.

**2.2** For calibration in accordance with 2.1 a calibration block to EN 12223 or EN ISO 7963/ISO 2400 shall be used when testing (hull) structural steels. Appropriate calibration or reference blocks shall be used for materials having other sound velocities (e.g. high-alloy steels and non-ferrous metals). Bore holes used for calibration shall not be larger than 2 mm and shall lie parallel to the testing surface. Where possible, calibration should not be performed at edges.

**2.3** Depending on the intended method of echo height definition, the sensitivity setting shall be performed using calibration reflectors of known shape, position and size (e.g. large flat reflectors, side-drilled holes) in accordance with the provisions of ISO 16811. Unless otherwise agreed, the DGS method of inspection shall be used. With the DGS method, the

sensitivity setting is to be carried out in accordance with the instrument manufacturer's instructions using calibration blocks to EN 12223 and EN ISO 7963/ISO 2400. Flat-bottom holes and grooves should not be used as calibration reflectors.

**2.4** If necessary (e.g. for defects close to the surface), the sensitivity setting is to be corrected in accordance with ISO 16811. When testing unalloyed and low-alloy (hull) structural steels and where the sonic distances are not too far (see ISO 16811), the sound attenuation may normally be disregarded. A transfer correction to determine the coupling differences between the surface of the reference block and that of the test piece shall, however, be performed in every case. The value of the transfer correction shall be stated in the inspection report.

**2.5** For more efficient detection of defects it is recommended that testing be performed with a test sensitivity (search sensitivity) increased by approximately 6 dB over the chosen registration level (see 5.1). However, the registration level setting is generally to be used when evaluating defect indications. All echo indications to be registered must attain at least 20 % of the display height even at the maximum sonic distance (see ISO 16811). In the case of electrogas welded seams, the inspection shall normally be performed with a sensitivity increased by 12 dB, and this fact shall be expressly stated in the inspection report with a reference to the welding process (e.g. EG + 12 dB).

### 3. Surface Preparation, Coupling

**3.1** On both sides of the welded seam (see 4.1) the testing surfaces must be smooth and free from impurities liable to interfere with coupling. Rust, scale and weld spatter are to be removed so that the probes lie snugly against the surfaces, which should if necessary be ground. Firmly adhering paint need not be removed provided that it does not interfere with the inspection and quantitative allowance can be made for the resulting loss of sensitivity when evaluating the echo heights.

**3.2** Where angle beam probes have to be applied

to the surface of the weld for the inspection of transverse defects (see 4.3), this shall also be prepared as a testing surface in the manner described above.

Notches, grooves and the like lying across the beam axis which produce false indications and may impair the test are to be removed.

**3.3** Coupling to the testing surfaces prepared in accordance with 3.1 should be as uniform as possible and should not vary by more than  $\pm 4$  dB. If greater variations are found, the condition of the surface shall be improved. Where greater variations cannot be avoided, this fact must be stated in the inspection report. Running water, cellulose glue, oils, grease or glycerine may be used as coupling media.

### 4. Scanning Directions, Angle of Incidence

**4.1** Unless otherwise agreed or stipulated, testing for longitudinal defects shall be performed from one surface and from both sides of the weld, as shown in Fig. 10.1. The testing area must embrace the weld metal itself and an area on both sides of the seam equal to about 1/3 of the wall thickness, subject to a minimum of 10 mm and a maximum of 20 mm. The testing surface must encompass a width at least equal to the full skip distance plus twice the length of the probe.

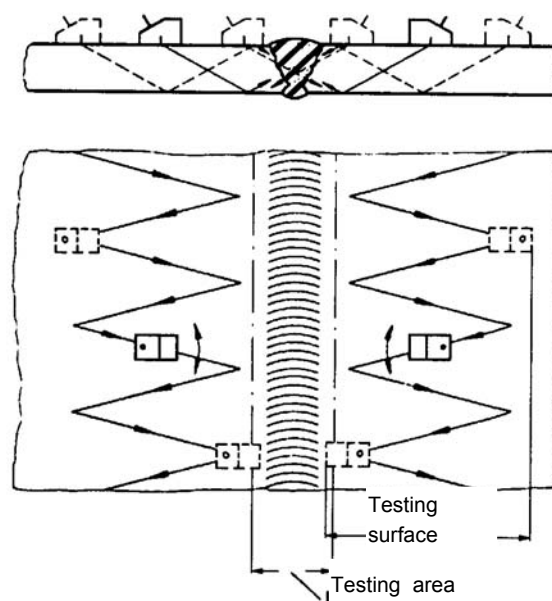

Figure 10.1 Testing for longitudinal defects

4.2 Depending on the weld geometry and the possible orientation of defects, it may be expedient to perform the test from both surfaces or (e.g. in the case of bevels) from only one side of the seam. With corner and T-joints, the testing shall normally be performed both from the side of the web and from that of the continuous (flange) plate using a standard probe, as shown in Fig. 10.2. Such probe arrangements differing from 4.1 shall be specially noted in the inspection report. The same applies in analogous manner to curved surfaces.

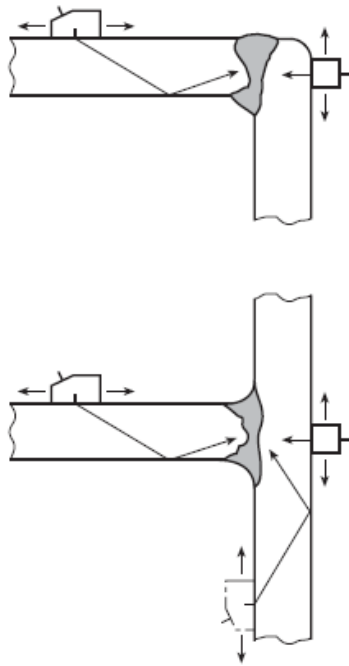

Figure 10.2 Testing for longitudinal defects in corner and T-joints

4.3 Testing for transverse defects shall be performed from both sides of the weld in two directions along the seam as shown in Fig. 10.3 or - where the test requirements are more stringent - on the face of the weld which has been machined flush with the surface. TL may require that testing for transverse defects be performed with two probes connected in parallel. Where welds are made with a large weld pool (as in electroslag welding), testing for oblique defects shall also be performed at an angle of approximately 45° (see EN ISO 17640).

4.4 With plate thicknesses (weld thicknesses) of less than 30 mm, testing may be performed with an angle of incidence of 70°. With thicknesses of 30 mm and over, two angles of incidence (70° and 45° or 60°)

shall be used. Where the surface is curved, the necessary angle of incidence shall be determined in accordance with ISO 16811. With very large wall thicknesses (above about 100 mm), the inspection must be performed using a tandem technique (with fixed, mechanical coupling of two similar probes) for different depth zones.

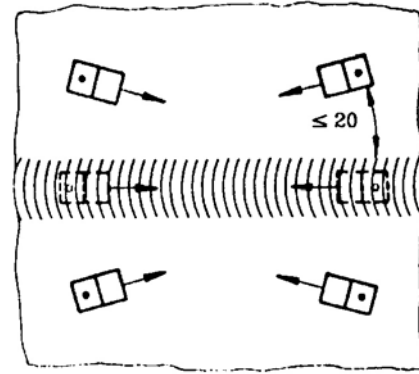

Figure 10.3 Testing for transverse defects

## 5. Registration Level, Evaluation of Echo Indications

### Note:

*Recommendations on the evaluation of the findings of ultrasonic inspections of fusion-welded joints (in steel) according to ISO 5817. The information sheet also contains information on the usefulness and performance of ultrasonic inspections and the evaluation of form-related indications.*

5.1 For tests carried out by the DGS method, the registration level (reference reflector size) for longitudinal and transverse defects is given by the diameters of the disc-shaped reflectors specified in Table 10.3 in relation to the wall thickness (weld thickness).

Table 10.3 Registration levels

Wall thickness (weld thickness)	Diameter of disc-shaped reflector	
	4 MHz	2 MHz
From 10 - 15 mm.	1,0 mm.	1,5 mm.
Over 15 - 20 mm.	1,5 mm.	2,0 mm.
Over 20 - 40 mm.	2,0 mm.	3,0 mm.
Over 40 - 60 mm.	3,0 mm.	4,0 mm.

Where the thickness is greater than 60 mm, the registration level will be determined on a case-by-case basis. For tandem testing, the registration level shall be determined by a 6 mm diameter disc-shaped reflector. For other methods of echo height definition (e.g. the reference block method), the registration level shall be determined in accordance with ISO 16811.

**5.2** The registration of non-form-related echo indications which are observed when inspecting welded joints and whose echo heights attain or exceed the registration level (reference reflector size) specified in 5.1 are required only when expressly stipulated by TL or where subsequent repeat tests have to be performed. Otherwise only those echo indications shall be registered which exceed the repair limit value specified in 5.4.

**5.3** One characteristic which is to be stated for the classification of echo indications is by how many dB the maximum echo height of the reflections found differs from the registration level defined in 5.1. In the case of the DGS method, the size of the (substitute) disc-shaped reflector may also be stated. Further characteristics to be stated are the registration lengths and half-value depths in accordance with EN ISO 17640. The location of reflections shall be defined by coordinates indicating the "longitudinal and transverse distances from a reference point" and the "depth position".

**5.4** Unless otherwise stated in Section 12 to 16, echo indications produced by longitudinal defects which exceed the repair limit values shown in Table 10.4 (excess of registration lengths and/or echo heights above the registration level shown in Table 10.3) shall be regarded as weld defects which must be repaired.

**5.5** Continuous echo indications which point to systematic weld defects (such as root defects due to incomplete penetration or rows of pores) call for repairs even if the repair limit values are not attained. Echo indications which point to the presence of cracks necessitate repairs in every case.

**5.6** Echo indications produced by transverse defects shall in every case count as weld defects requiring repair unless they can be unequivocally associated with the indications produced by longitudinal defects and remain below the repair limit values stipulated in Table 10.4.

**5.7** Where the evaluation of echo indications gives rise to doubt regarding the need for repair, recourse may be had to radiographic inspection to help in the assessment. However, echo indications obtained with welded seams 30 mm. or more in thickness which exceed the repair limit values invariably necessitate repair even if radiographic inspection fails to reveal any defects or fails to reveal them clearly.

## **6. Inspection Reports**

**6.1** Complete inspection reports as prescribed in EN ISO 17640 and containing the information listed below shall be prepared for all ultrasonic inspections in accordance with the inspection schedule; see D.1. The inspection reports must enable the inspections to be repeated identically. They must be signed by the person performing the inspection and the supervisor.

**6.2** Inspection reports must contain the following general information:

- Clear identification of the component, the material, the welded joint inspected together with its dimensions and location (sketch to be provided for complex weld shapes and testing arrangements) and the welding process.
- Indication of any other rules (e.g. specifications, standards or special agreements) applied to the inspection.
- Place and time of the inspection, testing body and identification of the person performing the test.

**6.3** Inspection reports must contain at least the following specific details relating to the inspection:

- Make and type of test equipment,
- Make, type, nominal frequency and angle of incidence of probes,
- Distance calibration (testing range),
- Sensitivity setting (calibration reflector used, instrument sensitivity, registration level),
- Correction values (for defects close to surface, transfer correction),

- Test sensitivity,
- Surface preparation, coupling media,
- Testing surfaces, testing directions, angles of incidence.

**6.4** The test results (where these are to be stated in the inspection report; see 5.2) shall, wherever possible, be tabulated or shown on sketches with the following details:

- Coordinates of defects with indication of reference point,

- Maximum excess echo height (+ ... dB) compared with the given registration level (reference reflector size) or, where applicable, the diameter of the corresponding (substitute) disc-shaped reflector
- Defect characteristics (registration length, half-value depth).

Where echo indications below the repair limit values shown in Table 10.4 are also registered, each defect thus identified is to be allocated an assessment (e.g. leave as is or repair, k = acceptable or ke = not acceptable).

**Table 10.4 Repair limit values**

Evaluation category according to G.2.1	Wall thickness (weld thickness) [mm]	Longitudinal defects			Transverse defects		
		Number of defects per m of weld seam	Registration length [mm]	Max. permissible excess echo height [dB]	Number of defects per m of weld seam	Registration length [mm]	Max. permissible excess echo height [dB]
B	10...15	10 and 3 and 1	10 20 10	6 6 12	3	10	6
	>15...20	10 and 3 and 1	10 20 19	6 6 12	3	10	6
	> 20...40	10 and 3 and 1	10 25 10	6 6 12	3	10	6
	> 40	10 and 3 and 1	10 30 10	6 6 12	3	10	6
C	10...20	10 and 3 and 1	15 30 10	6 6 12	3	10	6
	>20...40	10 and 3 and 1	15 30 10	6 6 12	3	10	6
	> 40	10 and 3 and 1	15 50 10	6 6 12	3	10	6
D	10...20	10 and 3 and 1	15 50 10	6 6 12	5	10	6
	>20...40	10 and 3 and 1	15 50 10	6 6 12	5	10	6
	> 40	10 and 3 and 1	20 50 10	6 6 12	5	10	6

## M. Magnetic Particle Inspection

### 1. Test Appliances and Media

1.1 The test appliances and media used must conform to the state of the art and the relevant standards (e.g. DIN 54130, EN ISO 9934-3, EN ISO 9934-2, EN 571-1, EN ISO 3452-2 and EN ISO 3452-3). The magnetizing equipment must be provided with markings or measuring devices which indicate the magnetizing current strength at any time. TL may stipulate that measurements be performed to verify these data. Proof of the suitability of the test media shall be furnished on request.

1.2 Magnetic particles suspended in suitable, readily volatile vehicle liquids shall be used as test media for revealing the leakage flux due to discontinuities in the material. These magnetic particles may be black or fluorescent. Where black magnetic particles are used, the surface to be tested shall be coated with a permanent white paint, applied as thinly as possible, to provide a contrast.

1.3 The proportion of magnetic particles in the vehicle liquid must conform to the manufacturer's instructions and shall be verified (e.g. by means of a test indicator or by a separation test using a glass centrifuge vessel to API MPMS Chapter 10.4). Dry test media may only be used for tests at elevated temperatures (e.g. on root passes).

### 2. Magnetization Method and Field Strength

2.1 The choice of the method of magnetization depends on the geometry of the component and is to be agreed with TL. If possible, magnetization shall be effected by passing a current through the work piece or, in the case of minor localized inspections, by yoke magnetization using electromagnets or, if no other possibilities are given, permanent magnets.

2.2 In special cases (e.g. where burn marks have to be avoided at all costs or for circumferential welds), it may be expedient to effect magnetization with a live conductor (a cable or coil). A combination of different methods of magnetization for the detection of variously orientated defects is allowed.

2.3 Where a current is passed through the work-piece, alternating, direct, impulse or surge current may be used. AC or DC magnets may be used for yoke magnetization. Where the magnetizing current is passed through the workpiece, fusible supply electrodes should be used to prevent burn marks. Where AC is used, fusible electrodes are obligatory.

2.4 The magnetizing field strength (effective tangential field strength) must be at least 20 A/cm (25 Oe) but shall not exceed 50 A/cm (62,5 Oe). The adequacy of the magnetization shall be checked at the time of the test by suitable means (e.g. test indicator) or with a tangential field strength meter.

### 3. Preparation of Testing Surfaces, Direction and Duration of Magnetization

3.1 The testing surfaces must be free from loose scale, rust, weld spatter and other impurities. Notches, grooves, scratches, edges, etc. which may produce false indications are to be removed prior to inspection. Thin, dry layers of paint (e.g. shop primer, up to a coat thickness of 20 µm) may be left in place as long as they do not hinder the inspection.

3.2 Magnetization must be effected, as shown in Fig. 10.4, in two different directions including an angle of not less than 60° and not more than 90° so as to enable variously orientated defects to be located.

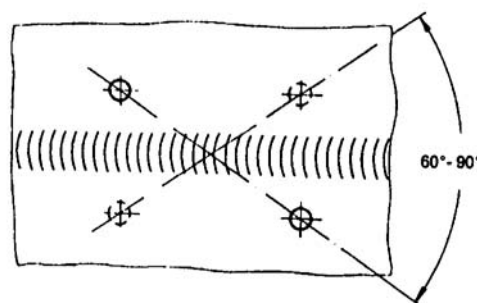

**Figure 10.4** Directions in which magnetization is to be effected

3.3 Magnetization must be continued as long as the testing surface is sprayed with magnetic particle suspension and for as long thereafter as any movement of the magnetic particle suspension can be detected, subject to a minimum of 5 seconds. Testing under



conditions of remanent magnetization is not permitted.

#### 4. Evaluation, Inspection Reports

**4.1** Every accumulation of magnetic particles not due to a false indication indicates a discontinuity or crack in the material which is to be registered in the inspection report and repaired. In the case of small cracks (e.g. end crater cracks) this may be done by grinding. Larger cracks are to be machined out and repair-welded; see I.1.2.

**4.2** Inspection reports relating to magnetic particle inspections must include the following details:

- Details of the component and weld concerned,
- Details of magnetization, with amperage where appropriate,
- Test arrangement (directions of magnetization, distance between electrodes or poles),
- Test media,
- Test results
- Place and time of the inspection, testing body and identification of the person performing the test.

#### N. Liquid Penetrant Inspection

##### 1. Test Media

**1.1** Coloured or fluorescent penetrant shall be used as penetrant media. Penetrant removers and developers must be compatible with the penetrant used. Proof of the suitability of the inspection system (penetrant, penetrant remover, developer) shall be furnished to TL on request.

##### 2. Preparation of Testing Surfaces, Performance of Inspection

**2.1** To allow the penetrant to enter any defects

present, the testing surfaces must be completely free from scale, rust, greases, oils, paints or electrodeposits before the penetrant is applied. During this operation care should be taken to ensure that defects are not mechanically sealed by preliminary cleaning. The testing surfaces must be dry. The temperature of the work piece shall be between 5 °C and 50 °C.

**2.2** Any method of applying the penetrant may be used. Care shall be taken to ensure that the testing surface is completely wetted throughout the entire penetration time. The penetration time shall be chosen in accordance with the manufacturer's instructions, but shall not be less than 15 minutes for work piece temperatures of 15 °C and over or less than 30 minutes where the temperature is below 15 °C. The penetrant shall not become dry during the penetration period.

**2.3** Following penetration, the surplus penetrant shall be completely removed from the testing surface in such a way as to leave behind the penetrant lodged in any defects present. It is advisable first to wipe off the surplus penetrant with a cloth and quickly to remove only the remains with sparing use of the penetrant remover. The testing surface should then be dried as quickly as possible (max. 50 °C).

**2.4** The developer is to be applied evenly and as thinly as possible immediately after removal of the surplus penetrant and drying. The testing surface should be just covered. The developing time should be about the same as the time allowed for penetration. Visual inspection for defects shall begin as the developer is applied, but the final inspection can only take place after the expiry of the developing time. M.4.1 applies in analogous manner to the evaluation.

##### 3. Evaluation, Inspection Reports

**3.1** Should an unequivocal evaluation of the indications be impossible, the entire inspection procedure, starting with preliminary cleaning, must be repeated. Where necessary, the surface quality shall also be improved. The repeat inspection must be performed with the same test system as on the first occasion. The conditions specified in standard ISO 3452-1 are also applicable.

**3.2** Inspection reports relating to penetrant medium inspections must include the following details:

- Details of the component and weld concerned,
- Test media (type, brand name),
- Description of the test procedure (temperature of the work piece, penetrant acting time, etc.)

- Test results,

- Place and time of the inspection, testing body and identification of the person performing the test.

Inspection reports shall conform to the form provided in Annex B to ISO 3452-1.

**SECTION 11****MECHANICAL AND TECHNOLOGICAL TESTS**

<b>A. SCOPE</b> .....	<b>11- 3</b>
<b>B. PREPARATION OF SPECIMENS AND TESTING</b> .....	<b>11- 3</b>
<b>C. TENSILE TESTS</b> .....	<b>11- 3</b>
1. Tensile Tests On Flat Tensile Specimens (DIN 50120, Part 1)	
2. Tensile Test On Round Tensile Specimens (EN 10002/DIN 50125)	
3. Tensile Tests On Cruciform Tensile Specimens	
<b>D. BEND TESTS</b> .....	<b>11- 5</b>
1. Transverse Bend Test (DIN 50121, Part 1)	
2. Side Bend Test (DIN 50121, Part 1)	
3. Bend Test Specimens From Pipe Joints	
<b>E. NOTCHED BAR IMPACT TESTS</b> .....	<b>11- 7</b>
<b>F. HARDNESS TESTING OF WELDS</b> .....	<b>11- 8</b>
<b>G. METALLOGRAPHIC INSPECTIONS</b> .....	<b>11- 9</b>
<b>H. INSPECTION REPORTS</b> .....	<b>11- 9</b>

**Preliminary remarks:**

*This section has, for the time being, still been retained in its earlier form despite the fact that more up-to-date EN and ISO standards have since been either issued or are available in draft form relating to the key destructive tests carried out on welded joints in metallic materials. The intention is to delete this section altogether at a later date and instead to make reference only to the new standards in Section 4, "Welding Procedure Tests" (where the information relating to the mechanical and technological tests is chiefly needed). These standards include:*

- *EN895/ISO4136  
Transverse tensile test (replacement for DIN 50120-1 and 50120-2)*
- *EN 876/ISO 5178  
Longitudinal tensile testing of the weld metal in fusion welded joints*
- *EN910/ISO5173  
Bend tests (replacement for DIN 50121-1 and 50121-2)*
- *EN875/ISO9016  
Notched bar impact test (replacement for DIN 50122)*

- *EN 1043/ISO 9015  
Hardness test, miscellaneous parts (Replacement for DIN 50163)*
- *EN 1320/ISO 9017  
Fracture tests (replacement for DIN 50127)*
- *EN 1321  
Macroscopic and microscopic examinations*
- *EN ISO 8249  
Determination of ferrite number*

*The mechanical and technological tests shall, wherever possible, be performed in accordance with the new standards. For an interim period, or where the new standards are not yet available, the mechanical and technological tests may continue to be performed in accordance with the following provisions. The test records shall state which rules were used as a basis for the test. Where the provisions given in the various rules differ widely, the procedure shall be agreed with **TL**.*

**A. Scope**

1. These Rules relate to the normal methods and forms of test specimens to be used in the mechanical and technological testing of welds, e.g. of test pieces for the welding procedure and workmanship tests, as well as to the metallographic inspections necessary for this purpose.

2. Special methods and forms of test specimens (e.g. for testing the manual skill of welders or testing of welding consumables, auxiliary materials and over-weldable shop primers) are specified in the relevant sections.

3. The test methods and forms of specimens indicated in the standards mentioned in the following paragraphs shall be used wherever possible. Methods and forms of specimens conforming to other standards may be used by agreement with the Surveyor, provided that the same results can be achieved.

**B. Preparation of Specimens and Testing**

1. All tests are to be performed by trained personnel using calibrated testing machines. The testing machines must be kept in good working order by their owners and are to be calibrated at regular intervals by an independent inspecting authority.

2. Before being cut out of the test piece, specimens are to be marked by the Surveyor. They shall then be cut out, wherever possible by a mechanical process, and machined to the required dimensions. Where specimens are cut from the test piece by a thermal process, they must be wide enough to ensure that the heat-affected zone can be completely machined off.

3. All mechanical and technological tests are to be performed in the presence of the Surveyor, unless otherwise stipulated or agreed. The photographs of metallographic specimens are to be submitted to him for evaluation.

**C. Tensile Tests**

**1. Tensile tests on flat tensile specimens (DIN 50120, Part 1)**

1.1 This test is carried out to determine the tensile strength, position, type of fracture and, where appropriate, the elongation of specimens located at right angles to the seam. The flat tensile specimen shown in Figure 11.1 should be used wherever possible.

1.2 The thickness 'a' of the specimen is normally the wall thickness. If this is greater than 30 mm. but less than 50 mm, the specimens may be machined down on one side to a thickness of 30 mm. With thicknesses of 50 mm. and over, two or more specimens regularly spaced over the section are to be prepared.

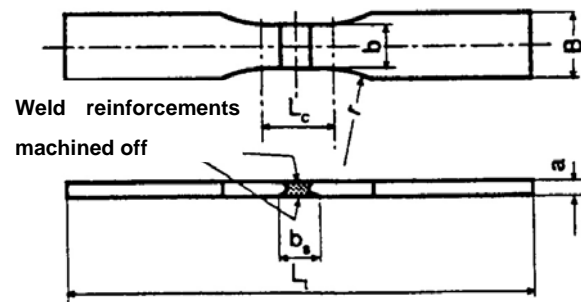

Specimen thickness (a)	≤ 5	> 5 to ≤ 10	> 10 to ≤ 20	> 20 to ≤ 30
	Specimen width (b)	15	20	25
Gauge length (L <sub>c</sub> )	Weld width b <sub>s</sub> + 80 mm.(1)			
Head width (B)	≥25	≥30	≥35	≥40
Total length (L <sub>t</sub> )	≥ L <sub>c</sub> + 180			
Radius at shoulder (r)	≥ 35			
(1) b <sub>s</sub> measured on the side of the weld the greater seam width.				

**Figure 11.1 Flat tensile specimen (welded joint)**

1.3 Welded joints in aluminium alloys shall be tested using a tensile specimen conforming to DIN 50123.

**2. Tensile test on round tensile specimens (EN 10002/DIN 50125)**

2.1 This test is carried out to determine the tensile strength, yield strength or 0,2 % proof stress, reduction in area and elongation of the weld metal. Where necessary in the case of high-temperature steels, the 0,2 % proof stress at elevated temperatures shall also be established. Wherever possible, the test should be performed on a 10 mm diameter round tensile specimen of the type depicted in Figure 11.2, which is to be cut out of the weld metal with its longitudinal axis in the direction of the seam. Location of specimens is to be taken as shown in Figure 11.3.

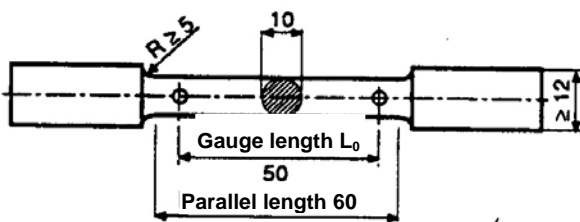

Figure 11.2 Round tensile specimen (weld metal)

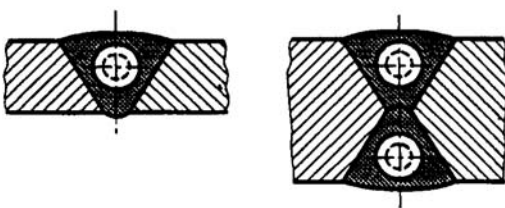

Figure 11.3 Location of specimens in weld metal

2.2 If, in exceptional cases, the weld dimensions do not permit the preparation of a 10 mm diameter tensile specimen, specimens with a smaller diameter may be used, provided that the gauge length is 5 times and the parallel length at least 6 times the diameter of the specimen

**3. Tensile tests on cruciform tensile specimens**

3.1 This test is carried out to determine the tensile shear strength  $Z_s$  of the weld metal. Three specimens with the dimensions shown in Figure 11.4 shall be tested in each test

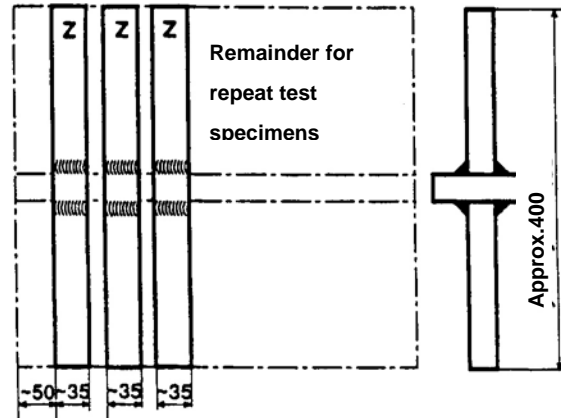

Figure 11.4 Cruciform tensile specimens

3.2 The tensile shear strength  $Z_s$  is to be determined by the following formula (cf. Figure 11.5):

$$a_1 + a_2 = \text{fracture section } S_{1/2}$$

$$a_3 + a_4 = \text{fracture section } S_{3/4}$$

Tensile shear strength  $Z_s$ :

$$= \frac{\text{Breaking load } F}{S_B \cdot \text{Specimen width}} \quad \left[ \text{N/mm}^2 \right]$$

$$S_B = S_{1/2} \text{ or } S_{3/4} \text{ depending on location fracture}$$

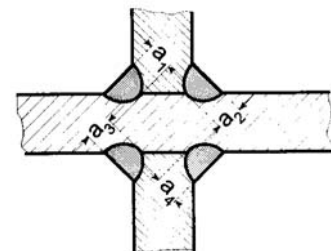

Figure 11.5 Cruciform tensile specimen, section through welded joint

## D. Bend Tests

### 1. Transverse bend test (DIN 50121, Part 1)

1.1 This test is carried out to determine the ductility of the welded joint across the seam. For this purpose the specimen is bent over a mandrel or prescribed diameter and the angle achieved and, if specified, the bending elongation on the tension side of the specimen are measured. Specimens to Figure 11.6 are to be prepared for the test

1.2 The thickness of the specimen is normally the wall thickness. If this is greater than 30 mm, the specimens may be machined down on one side to a thickness of 30 mm. On the side of the specimen which is in tension during the test, the edges may be rounded to the specified radius  $r$ .

1.3 Depending on the test specification, the specimens are to be mounted in the testing device in such a way that either the upper or the lower side of the weld is in tension during the test. The test rig is to be set up as shown in Figure 11.7.

1.4 If the bending elongation is to be determined, the deformation zone on the tension side of the specimen shall be provided prior to the test with gauge marks set 5 mm. apart and these shall be used to measure the elongation when the prescribed bending angle has been reached.

The gauge length  $L_0$  is the weld width plus the wall thickness.

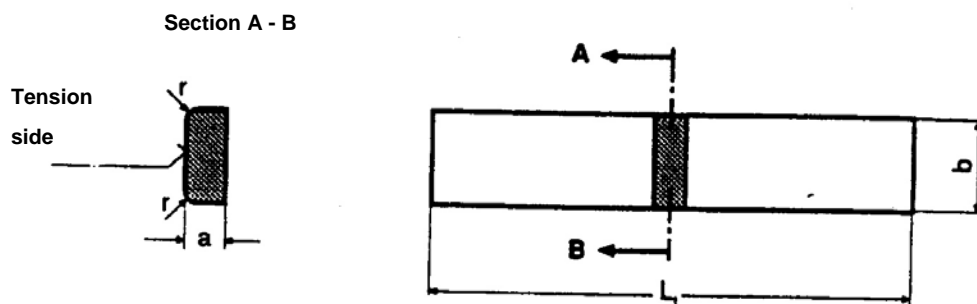

Dimensions		Specimen thickness a					
		≤11	>11 ≤14	>14 ≤17	>17 ≤22	>22 ≤27	>27 ≤35
Specimen width (b)		20	30	30	≥ 1,5 a	≥ 1,5 a	≥ 1,5 a
Specimen length $L_t$ (1) where	$\frac{d}{a} \leq 3$	250	250	250	250	300	380
	$\frac{d}{a} = 4$	250	250	250	290	350	430
	$\frac{d}{a} = 6$	250	250	290	350	430	530
Radius r, side in tension		≤ 2	≤ 2	≤ 2	≤ 3	≤ 3	≤ 3
(1) If the specimen lengths $L_t$ cannot be met, the minimum specimen lengths shown in Table 6 of DIN 50121, Part 1 apply.							

Figure 11.6 Specimen for transverse bend test

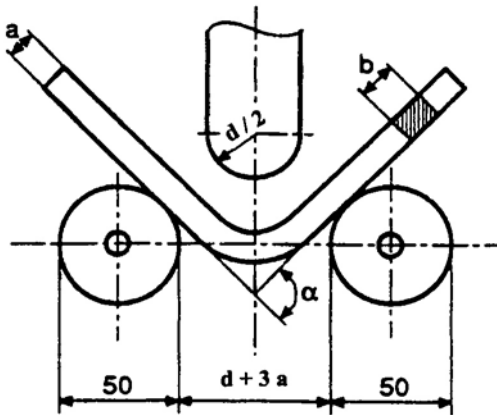

Figure 11.7 Test rig

1.5 If the elongation behaviour of the base material and the weld metal differ greatly, e.g. in the case of welded aluminium test pieces, the test rig shown in Figure 11.8 may be used in order to prevent premature incipient cracking of the specimen.

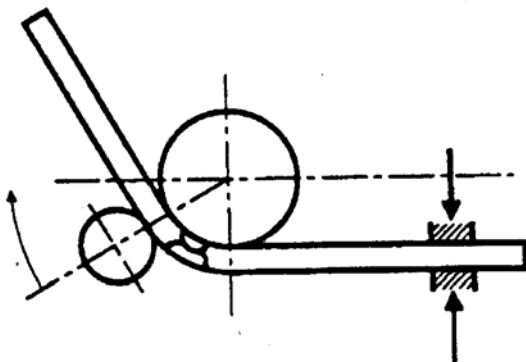

Figure 11.8 Special test rig

2. Side bend test (DIN 50121, Part 1)

2.1 This test is carried out to determine the ductility of the welded joint in the cross-sectional plane. For this purpose the specimen is bent over a mandrel of specified diameter and the bending angle attained is measured. Specimens to Figure 11.9 are to be prepared for the test.

2.2 The specimens are to be mounted in the testing device shown in Figure 11.7 in such a way that

the testing load acts in the direction of the original longitudinal axis of the seam. On the side in tension during the test, the long edges of the specimen may be rounded to the specified radius r.

2.3 If welded clad plates are to undergo side bend tests, the form of specimen shown in Figure 11.10 is to be used. The dimensions are as stated in the table in Figure 11.9.

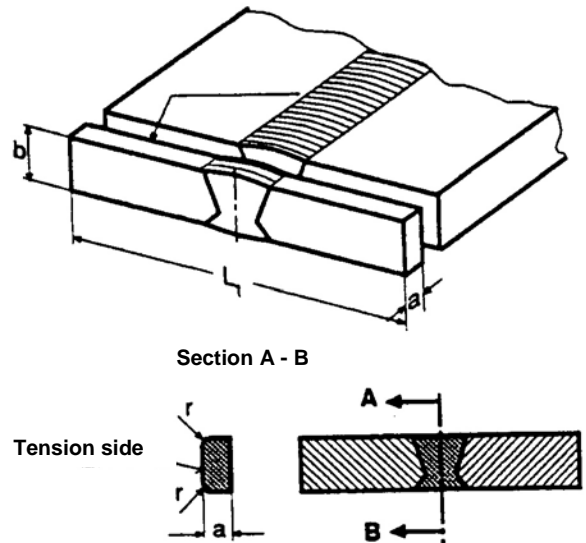

Dimensions	Ratio d/a		
	≤ 3	4	6
Specimen thickness a	10		
Specimen width b	Product thickness		
Radius r, side in tension	≤1 (≤3) (1)		
Specimen L <sub>t</sub> (2)	150	170	200

(1) The radius in brackets applies to specimen where the weld reinforcements are not machined off.  
 (2) If the specimen lengths L<sub>t</sub> cannot be met, the minimum specimen lengths shown in Table 6 of DIN 50121, Part 1 apply.

Figure 11.9 Specimen for side bend test



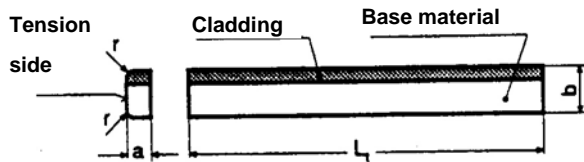

Figure 11.10 Form of clad side bend test specimens

### 3. Bend test specimens from pipe joints

If bend test specimens are to be taken from circumferential pipe welds, the side faces must be parallel. If necessary, the side of the specimen which is in compression shall be machined in accordance with Figure 11.11.

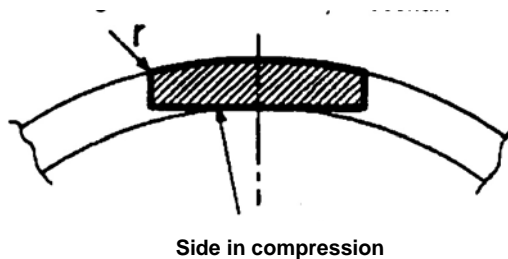

Figure 11.11 Cross section through bend test specimen taken from a pipe

### E. Notched Bar Impact Tests (EN 10045/DIN 50115)

1. The purpose of this test is to determine the impact energy in joules (J). ISO V-notch specimens shall be used; their location in the test piece shall be such that the longitudinal axis of the specimen is perpendicular to the direction of the seam while the notch axis is at right angles to the surface of the product (cf. Figure 11.12). In addition, determination of the crystalline portion of the fracture surface and/or of the lateral expansion of the specimen may be agreed.

2. Depending on the test specification, the notch shall be located either at the centre of the weld metal, on the fusion line or in the heat-affected zone of the base metal at a specified distance from the fusion line (cf. Figure 11.12).

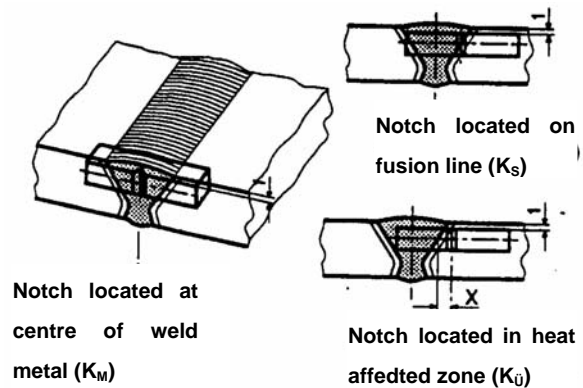

Figure 11.12 Location of specimens for notched bar impact testing

3. The test is to be carried out at the specified test temperature. Where the product thickness is < 10 mm, specimens measuring 7,5 x 10 mm, 5 x 10 mm. and 2,5 x 10 mm. should be used wherever possible. For these specimens the required impact energy E (J) in relation to the standard 10 x 10 mm. test specimen shall be as indicated in the table below.

Cross section of specimen [mm]	Mean impact energy value required [E]
Standard specimen 10 x 10	E
Specimens of reduced section 10 x 7,5 10 x 5	5/6 E 2/3 E

4. Where specimens are taken from only one side of a double-V weld, they shall be taken from the side of the seam which was welded last.

5. The specimens shall be machined down to the dimensions shown in Figure 11.13 and compliance with the stipulated tolerances shall be verified.

6. If in technically justified exceptional cases specimens with forms or locations different from those described in paras. 1 to 5 are to be used, the test requirements shall be specially agreed with TL.

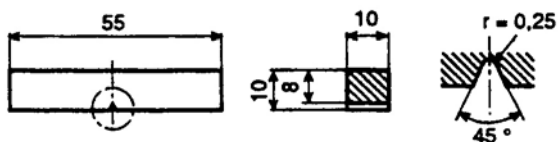

Dimension	Nominal size	Tolerance
Length	55 mm.	$\pm 0,60$ mm.
Width	10 mm.	$\pm 0,11$ mm.
Height	10 mm.	$\pm 0,06$ mm.
Notch angle	45°	$\pm 2^\circ$
Height from bottom of notch	8 mm.	$\pm 0,06$ mm.
Notch radius	0,25 mm.	$\pm 0,025$ mm.
Distance between centre of notch and ends of specimen	27,5 mm.	$\pm 0,42$ mm.
Angle between plane of symmetry of notch and longitudinal axis of specimen	90°	$\pm 2^\circ$
Angle between adjacent longitudinal specimen surfaces	90°	$\pm 2^\circ$

Figure 11.13 ISO-V notch specimen

#### F. Hardness Testing of Welds (DIN 50163, Part 1)

1. The hardness of welded joints shall be measured by Vickers hardness tester using a load of 49 or 98 N (HV 5 or HV 10) on polished and etched specimens whose test face is perpendicular to the weld axis. The choice of the test load depends on the grade of material concerned.

2. Normally, the test shall take the form of rows of hardness measurements, one row for fillet welds and

at least two rows for butt welds, one of which is at the root and one in the area of the cover pass. Should this be insufficient for an adequate assessment of the hardness of the welded joint, a test with a further row of measurements shall be performed, e.g. in the area of the root and capping passes in the case of butt welds. The arrangement of the rows of hardness measurements shall be as shown in Figure 11.14.

3. The impressions made by the hardness tester shall be close enough together to give an accurate picture of the hardness curve (cf. Figure 11.15). The curve shall be plotted as a graph wherever possible.

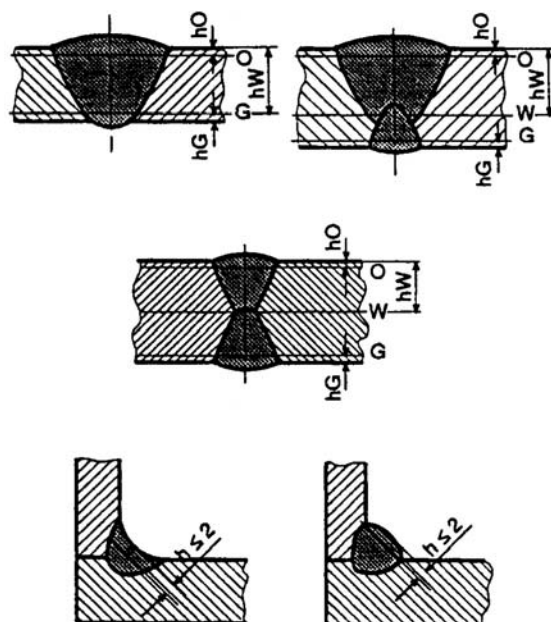

$hO$  = Distance from the surface

$hG$  = Distance from the underside

$hW$  = Distance of the row of hardness measurements for the root area from the surface

Figure 11.14 Hardness testing with rows of hardness measurements

### G. Metallographic Inspections

1. The macro- and micro-structure shall be evaluated by reference to polished sections. Unless otherwise agreed, the polished face of the sections shall be perpendicular to the weld axis (see also Figure 11.14).

2. The metallographic specimens shall be of such a size and ground and etched in such a way as to reveal the nature and structure of the crystallization of the weld metal and the heat-affected zone as well as the texture of the base metal and, in the case of micrographs, the grain boundaries in the area under examination.

3. The polished sections shall be photographed and the photos appended to the inspection report. Macrographs shall normally be to a scale of 1 : 1 to 1 : 3; if the cross-sectional area of the weld is small, they may be magnified.

For assessment of the microstructure, at least 3 photographs shall be made of characteristic parts of the weld; these shall generally be the weld metal, the fusion line and the heat-affected zone. The magnification shall be at least 100 : 1.

### H. Inspection reports

1. The works must prepare reports on the tests, which must contain all the necessary details for assessing the method. These especially include:

- Type of inspection or test (e.g. welding procedure test),
- Dimensions and numbers of test pieces,
- Base materials,
- Weld preparation,
- Welding processes and positions,

- Welding consumables and their dimensions, auxiliary welding materials,
- Welding current source,
- Welding current strength and voltage,
- Post-weld heat treatment,
- Test methods and forms of specimens,
- Test results.

2. The reports shall be submitted to the Surveyor in at least two copies for his perusal. He shall confirm the proper performance of the inspection and the correctness of the results by applying his stamp and signature.

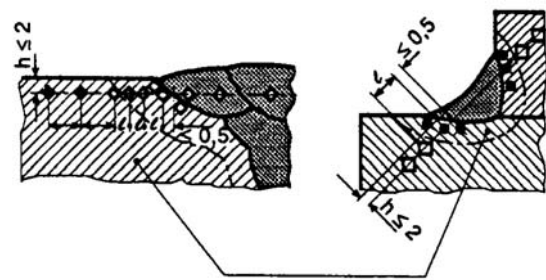

Heat-affected zone

Recommended distance  $l$  between hardness test impressions in the heat-affected zone

Vickers hardness symbol	Distance between hardness test impressions $l$ [mm]
HV 5	0,7
HV 10	1

Figure 11.15 Location of hardness test impressions in the heat-affected zone

**SECTION 12****WELDING OF HULL STRUCTURES**

<b>A.</b>	<b>GENERAL</b> .....	<b>12- 3</b>
	1. Scope	
	2. Other Relevant Rules and Regulations	
	3. Weld Performance	
<b>B.</b>	<b>APPROVAL OF SHIPYARDS AND WELDING SHOPS, WELDING PERSONNEL</b> .....	<b>12- 3</b>
	1. Works and Subworks	
	2. Requirements, Scope of Approval	
	3. Basic Approval, Extensions	
<b>C.</b>	<b>QUALITY INSPECTION, RESPONSIBILITY</b> .....	<b>12- 4</b>
<b>D.</b>	<b>MATERIALS, WELDABILITY</b> .....	<b>12- 5</b>
<b>E.</b>	<b>WELDING CONSUMABLES AND AUXILIARY MATERIALS</b> .....	<b>12- 5</b>
<b>F.</b>	<b>WELDING PROCEDURES, WELDING PROCEDURE TESTS OF STEELS FOR HULL CONSTRUCTION AND MARINE STRUCTURES</b> .....	<b>12- 7</b>
	1. General	
	2. Scope of tests, test schedule, limits of application and range of approval	
	3. Test pieces, dimensions, direction of rolling, welding positions	
	4. Sets of specimens, test specimens, mechanical and technological tests	
	5. Requirements	
<b>G.</b>	<b>DESIGN, DIMENSIONING</b> .....	<b>12-31</b>
	1. General	
	2. Characteristics Related to Materials, Corrosion	
	3. Stress Flow, Transitions	
	4. Local Clustering of Welds, Minimum Spacing, Socket Weldments	
	5. Welding Apertures	
	6. Local Reinforcements, Plate Doublings	
	7. Transverse Members, Stress in the Thickness Direction	
	8. Welding of Cold-Formed Sections, Bending Radii	
	9. Build-up Welds on Rudderstocks and Pintles	
	10. Weld Shapes and Dimensions	
	11. Welding at the Ends of Girders and Stiffeners	
	12. Joints Between Section Ends and Plates	
	13. Welded Shaft Bracket Joints	
	14. Rudder Coupling Flanges	
	15. Design Calculations Applied to Welded Joints	

<b>H.</b>	<b>EXECUTION OF WELDS</b> .....	<b>12-43</b>
	1. General	
	2. Welders and Supervisors	
	3. Weld Preparation and Assembly	
	4. Weather Protection, Welding at Low Temperatures	
	5. Preheating	
	6. Welding Positions, Vertical-Down Welding	
	7. Welding Sequence	
	8. Performance of Work	
	9. Welding of Higher-Strength Hull Structural Steels And High-Strength (Quenched And Tempered) Fine-Grained Structural Steels	
	10. Welding of Stainless and Clad Steels	
	11. Welding of Steel Castings and Forgings	
	12. Welding of Aluminium Alloys	
	13. Underwater Welding	
<b>I.</b>	<b>INSPECTION OF WELDED JOINTS</b> .....	<b>12-50</b>
	1. General	
	2. Workshop Inspections, Visual Examination	
	3. Non-Destructive Tests	
	4. Production Specimens	
	5. Leakage Tests	
	6. Weld Quality Grades, Scope of Tests, Test Methods, Requirements	
<b>J.</b>	<b>WELDING REQUIREMENTS for CARGO TANKS of GAS TANKERS</b> .....	<b>12-55</b>
	1. Welding and Non-Destructive Testing	

**A. Genel****1. Scope**

**1.1** These rules apply to all welding work carried out on the ship's hull, including the superstructure and deckhouses, its internal and external structures, and equipment components forming part of the ship's structure, e.g. hatch covers, masts, king posts or crane substructures welded to the ship's hull. See also Section 1, A.1. and A.2.

**1.2** IACS Rec 47 will be used as a guidance on shipbuilding for the hull structure and repair of hull structures of existing ships.

**1.3** They also apply in analogous manner to cargo tanks form an integral part of the ship's hull. (Tanks and pressure vessels stated in Section 14 which are not an integral part of the ship's hull are excluded) e.g. prismatic type A tanks in liquefied gas tankers.

**2. Other Relevant Rules and Regulations**

The design and dimensioning of welded joints is also governed by the provisions of the Chapter 1 - Hull, Sections 20) and the performance of the work is also subject to the provisions of Section 1, N. of the said Rules. For other relevant standards, see Section 1, B.

**3. Weld Performance**

Welded joints in hull structures shall be prepared, made and inspected in such a way that their quality characteristics are equivalent to those of the base materials to be joined. This means that they may not deviate from the prescribed form and internal condition by more than the limits allowed by the prescribed weld quality grades according to Table 12.10 or by the evaluation categories used as a basis for the notch category classification for the proof of fatigue strength (see Chapter 1 - Hull Hull, Section 3, D). The same applies in analogous manner to the other quality characteristics; see also C.

**B. Approval of Shipyards and Welding Shops, Welding Personnel****1. Works and Subworks**

**1.1** In the following items, the term "welding shop" refers to the shipyard or welding fabrication shop which may be considered an independent unit with regard to its physical and organizational situation.

**1.2** Branches and subcontractors are thus generally deemed to be "independent" welding shops which have to satisfy the requirements prescribed below. In particular, every welding shop must have a welding supervisor who is a permanent member of the welding shop staff (see Section 2).

**1.3** Outside firms working in welding shops may be granted approval as independent welding shops. On this and on temporary workers, see also C.3. and Section 1, F.

**2. Requirements, Scope of Approval**

**2.1** All shipyards and welding shops intending to perform welding work covered by these rules must satisfy the requirements relating to the welding shop and its personnel set out in Section 13 and must have been approved for this work by **TL**. Applications for approval shall be submitted by the shipyards and welding shops in good time before starting the welding work, enclosing the information and documentation prescribed in Section 2, A.3.

**2.2** Welding personnel (welders, operators and supervisory staff) and where applicable inspectors and test supervisors must meet the requirements set out in Section 2, B.2. and B.3. and be recognized by **TL**. For welder's qualification tests, see Section 3.

**2.3** The scope of the approval is determined by the capabilities of the welding shop and by the intended range of application (materials, welding processes, welding positions, etc.). For the period of validity of the approval, see Section 2, A.4. and A.5.

### 3. Basic Approval, Extensions

**3.1** For welding hull structures, as a general rule (basic) approval is granted first of all on the basis of a works inspection and, if necessary, welder's qualification tests in accordance with Section 3 normally for manual arc welding (welding process 111) and/or for semi-mechanized metal-arc active gas welding using solid and flux-cored wire electrodes (welding processes 135 and 136) of normal-strength hull structural steels A to D and other comparable grades of forged and cast steel. The thickness range is in this case determined by the scope of the valid welder's qualification tests.

**3.2** Exceptions to this rule are single-side welding and vertical-down welding using these processes (111, 135, 136), for which welding procedure tests shall be performed in every case. See F. One-wire submerged-arc welding (welding process 121) may also be covered in the basic approval described in 3.1 on the basis of documentary proof in accordance with F.1.4 (for conventional welding in one run on each side [two-run technique] on plates 4 to 25 mm thick and for multipass welding up to 40 mm).

**3.3** Basic approval may be extended to include any welding procedure approvals on the basis of welding procedure tests as set out in Section 4 (see also F.); in exceptional cases, however, limited approval may also only be granted (in conjunction with a works inspection) for a specific material and/or welding process.

### C. Quality Inspection, Responsibility

**1.** Shipyards and welding shops shall ensure by means of regular in-house quality inspections during fabrication and on completion of the welding work that this work has been performed competently and satisfactorily (see Section 1, F.). For the duties and responsibilities of the welding supervisor, see also ENISO 14731.

**2.** The shipyards and welding shops are responsible for ensuring that the welding work conforms to these Rules, the approved manufacturing documents,

any conditions stipulated in the approval documents, good shipbuilding practice and the latest state of welding practice. The inspections and checks to be performed by TL's Surveyor do not relieve the welding shops of this responsibility.

**3.** With regard to quality inspections and the responsibilities involved in awarding subcontracts to independent branches or suppliers or to approved or non-approved outside firms working in the welding shop (subcontractors), see Section 1, F. Subcontracting of work or employment of temporary workers shall be notified to TL.

**4.** The scope of the required quality inspections depends on the construction project in question. It is essential to ensure, however, that the intended materials, welding consumables and auxiliary materials are used and that the weld preparation, assembly, execution of the tack and final welds and the dimensional accuracy and completeness of the welded joints meets the requirements stated in 2. For non-destructive testing of the welded joints, see I.

**5.** Following inspection and, if necessary, repair by the welding shop, the components shall be presented to TL's Surveyor for checking at suitable stages of fabrication. For this purpose they shall be readily accessible and shall normally be uncoated. Where the previous inspection has been inadequate, the Surveyor may reject components and require that they be presented again after satisfactory workshop inspection and any necessary repair work has been performed.

**6.** If the quality or good working order of a component cannot be guaranteed or is in doubt due to inadequate or missing information in the manufacturing documents (e.g. production drawings), TL may demand appropriate improvements. This applies in analogous manner to supplementary or additional components (e.g. reinforcements), even if these components were not stipulated when the drawings were scrutinized or could not be stipulated due to insufficiently detailed representation in the class plans (see Section 1, G).

7. **TL** is not responsible for guaranteeing that all the components and welded joints inspected to the prescribed extent (generally on a random basis) by its surveyors have been fabricated in accordance with the conditions and meet the requirements in every respect. Components or welded joints which subsequently turn out to be defective may be rejected or their repair may be demanded even if acceptance testing has already been carried out.

#### **D. Materials and Weldability**

1. Welded structures may only be fabricated using base materials of proven weldability. Materials must comply with the Chapter 2 - Material. Other comparable materials (e.g. structural steels conforming to EN 10025-1) may only be used **TL** has given its approval in each individual case.

2. Any conditions relating to working and welding imposed by the approval certificate and the recommendations of the material producer shall be complied with. For the selection of materials for the ship's hull, see the Chapter 1 - Hull.

3. The weldability of normal-strength hull structural steels of quality grades A, B, D and E tested by **TL** is considered proven. No measures above and beyond the provisions of these Rules for Welding are necessary when welding these steels.

4. The weldability of the higher-strength hull structural steels of quality grades A 32 to F 40 approved and tested by **TL** in accordance with the Rules for Materials has been checked and can be taken for granted if the work is carried out in accordance with normal shipbuilding practice.

5. High-strength (quenched and tempered) fine-grained structural steels, steels tough at subzero temperatures, stainless structural steels and other (alloy) structural steels have to be specially approved by **TL**. The weldability of the steel in question must have been verified in combination with welding processes and welding consumables.

6. Steel castings and forgings shall comply with the Rules for Materials and shall have been tested by **TL**. The carbon content of components made from carbon and carbon-manganese steels/castings for welded structures shall not exceed 0,23 % C at ladle analysis (check analysis: max. 0,25 % C).

7. Light metal alloys must have been tested by **TL** in accordance with the Chapter 2 - Material. Their weldability must have been verified in combination with welding processes and welding consumables. It can generally be taken for granted in the case of the alloys mentioned in the Chapter 2 - Material-s.

#### **E. Welding Consumables and Auxiliary Materials**

1. All the welding consumables and auxiliary materials used (e.g. covered electrodes, wire-gas combinations, wire-flux combinations, etc.) must have been approved by **TL** in accordance with Section 5. The quality grade required depends on the base materials to be welded and is shown in the relevant tables in Section 5, except for hull structural steels and other comparable structural steels, forged steels and cast steels.

2. The correlation of the required quality grades of welding consumables and auxiliary materials for welding hull structural steels to the respective hull structural steel quality grades is shown in Table 12.1. The correlation to other comparable structural steels, forged steels and cast steels shall be undertaken in analogous manner.

3. For welding of different quality grades of hull structural steel, welding consumables and auxiliary materials shall be correlated to the steels by their quality grades and added symbols as follows:

**3.1** Normal-strength hull structural steels of different quality grades:

Welding consumables and auxiliary materials for whichever is the higher-quality (tougher) hull structural steel, e.g. A with D: quality grade 2 ....



**3.2** Higher-strength hull structural steels of the same strength but with different quality grades:

Welding consumables and auxiliary materials for whichever is the higher-quality, (tougher) hull structural steel, e.g. A 36 with E 36: quality grade 3 Y....

**3.3** Normal-strength with higher-strength hull structural steels with comparable quality grades:

Welding consumables and auxiliary materials for the normal-strength hull structural steel quality grade in question, e.g. D with D 36: quality grade 2 . (without added symbol Y)

**3.4** Normal-strength with higher-strength hull structural steels with non-comparable quality grades:

Welding consumables and auxiliary materials having a quality grade for the higher-quality hull structural steel but the strength of the normal-strength steel, e.g A with D 36:quality grade 2 (without Y symbol added)

**4.** For welding very thick-walled, rigid components (approx. 30 mm and over) and welding of forgings and steel castings, hydrogen-controlled welding consumables and auxiliary materials of quality grade 3 H15(H) shall be used (for higher-strength hull structural steels, 3Y H10(HH)).

**5.** The use of hydrogen-controlled welding consumables and auxiliary materials is recommended for welding of higher-strength hull structural steels to one another (and to lower-strength steels) if the carbon equivalent of these steels is over 0,41 %. See also H.5.

**6.** Hydrogen-controlled welding consumables and auxiliary materials should also be used for components which are subjected to full load immediately after welding (e.g. lifting lugs or as a result of pressure tests) or where allowance has to be made for a high degree of residual stress due to the rigidity of the structure and, where applicable, a high yield strength or strength of a structure

**7.** Hydrogen-controlled welding consumables and auxiliary materials shall always be used for welding high-strength (quenched and tempered) finegrained

structural steels and steels tough at sub-zero temperatures, see Section 5, F.4. For steels with a yield strength or 0,2 % proof stress of up to 500 N/mm<sup>2</sup>, welding consumables and auxiliary materials with the maximum added symbol H 10 (HH) should be used and for steels with a yield strength or 0,2 % proof stress of over 500 N/mm<sup>2</sup> those with a maximum added symbol H 5 (HHH) should be used.

**8.** For welding of austenitic stainless steels to one another and to hull structural steels, welding consumables and auxiliary materials shall be selected in accordance with Tables 5.21 to 5.23 in Section 5 and the manufacturers' recommendations, taking the corrosion resistance and strength requirements and the welding metallurgy (including resistance to hot cracking) into account, and specified in a welding schedule, which is to be submitted for approval.

**9.** For welding aluminium alloys, the welding consumables and auxiliary materials shall be selected according to the type and condition of the material (see Chapter 2 - Materials, Section 8) in accordance with Table 5.23 in Section 5 taking the required mechanical properties of the welded joints into account (see Chapter 1 - Hull, Section 20) and shall be indicated in the production documents to be submitted for approval.

**10.** Welding consumables and auxiliary materials specified in a welding shop or procedure approval (see F.) may only be replaced by equivalent consumables approved by **TL** with an appropriate quality grade if this is explicitly stated in the respective approval document. Failing this, **TL's** agreement shall be obtained.

**11.** The welding consumables and auxiliary materials may only be used in the approved welding positions. The manufacturer's recommendations and instructions for welding (e.g. type of current and polarity) shall be followed.

**12.** The welding consumables and auxiliary materials (especially hydrogen-controlled, basic covered electrodes and basic welding fluxes) shall be re-dried before use in accordance with the manufacturer's instructions (observe maximum drying time!) and stored in a dry place (in heated containers or the like) at the workplace.

Table 12.1 Correlation of welding consumables and auxiliary materials to hull structural steel quality grades

Quality grades of welding consumables and auxiliary materials (see also E.3.)	Hull structural steel quality grades											
	TL-A	TL-B	TL-D	TL-E	TL-A32/36	TL-D32/36	TL-E32/36	TL-F32/36	TL-A40	TL-D40	TL-E40	TL-F40
1, 1S, 1T, 1M, 1TM, 1V	X											
1YS, 1YT, 1YM, 1YTM, 1YV	X	(1)			X(2)(3)							
2, 2S, 2T, 2M, 2TM, 2V	X	X	X									
2Y, 2YS, 2YT, 2YM, 2YTM, 2YV	X	X	X		X (3)	X (3)						
2Y40, 2Y40S, 2Y40T, 2Y40M, 2Y40TM, 2Y40V	(1)	(1)	(1)		X (3)	X (3)			X (3)	X (3)		
3, 3S, 3T, 3M, 3TM, 3V	X	X	X	X								
3Y, 3YS, 3YT, 3YM, 3YTM, 3YV	X	X	X	X	X (3)	X (3)	X (3)					
3Y40, 3Y40S, 3Y40T, 3Y40M, 3Y40TM, 3Y40V	(1)	(1)	(1)	(1)	X (3)	X (3)	X (3)		X (3)	X (3)	X (3)	
4Y, 4YS, 4YT, 4YM, 4YTM, 4YV	X	X	X	X	X (3)	X (3)	X (3)	X (3)				
4Y40, 4Y40S, 4Y40T, 4Y40M, 4Y40TM, 4Y40V	(1)	(1)	(1)	(1)	X (3)	X (3)	X (3)	X (3)	X (3)	X (3)	X (3)	X (3)
<p>(1) Not to be used if possible, otherwise only with <b>TL's</b> approval; see Section 5; A.4.1 and A.4.2 apply in analogous manner.</p> <p>(2) For A 32/36, welding consumables and auxiliary materials of quality grade 1 Y ... should where possible only be used when welding thinner plates (up to 25 mm max.).</p> <p>(3) For plates over 50 to 70 mm thick, welding consumables and materials with one quality grade higher shall be used and for those over 70 and up to 100 mm thick those with two quality grades higher shall be used in each case in compliance with the higher base material requirements, see Rules for Materials.</p> <p><b>Note:</b> For steels F 32, F 36 and A 40 to F 40, no provision is made in the Chapter 2 - Material for plates above 50 mm thick, but these shall be subject to special agreements where appropriate.</p>												

## F. Welding Procedures, Welding Procedure Tests of Steels for Hull Construction and Marine Structures

### 1. General

1.1 Only welding procedures whose suitability for the application in question is evident from general experience or has been verified by means of a welding procedure test in accordance with Section 4 and the

following provisions may be used. Table 4.1 in Section 4 gives a list of the requisite verifications. The welding procedure must have been approved by **TL** for the welding shop in question (see also B.).

**Note:**

In principle, **TL** recognizes all welding processes which satisfy the above conditions. General reservations only exist to the extent that the operationally safe handling of these

*processes and the quality attainable under field conditions is called into question or contradicted by practical experience. For instance, at present no approvals are being granted for vertical-down gas-shielded welding with solid wires under mixed gas containing less than approximately 30 % CO<sub>2</sub> due to the risk of lack of side wall fusion. Exceptions to this rule are possible if welding using robots is required, for which the welding parameters and the manipulation of the torch may be prescribed and followed so precisely that it can be verified that welding has been performed with good penetration within the narrow "safe" area.*

**1.2 TL** may approve specific welding processes such as vertical-down welding, build-up welding on rudderstocks or underwater welding, the use of which is, however, dependent upon authorization, for example following an examination of the load conditions, in each individual case. For welding processes or applications of this nature, **TL** may also stipulate restrictions in the operation of the vessel (e.g. in the operating area).

**1.3** Welding procedure tests are intended to verify that a manufacturer is adequately qualified to perform welding operations using a particular procedure.

In general welding procedure tests are to reflect fabrication conditions in respect to welding equipment, inside or outside fabrication, weld preparation, preheating and any post weld heat treatment. It is to be the manufacturer's responsibility to establish and document whether a procedure is suitable for the particular application.

For the welding procedure approval the welding procedure test is to be carried out with satisfactory results. Welding procedure specifications are to refer to the test results achieved during welding procedure qualification testing.

Welding procedures qualified at a manufacturer are valid for welding in workshops under the same technical and quality management.

Welding procedure tests supervised by **TL** for verification of satisfactory operational handling and a trouble-free execution of the procedure, and also adequate quality properties for the welded joints made

under production conditions at the user's works are in general required for:

- Materials **(1)** other than "simple-to-weld" hull structural steels A to D and comparable structural steels, forged steels and cast steels and also for composite materials,
- Welding processes **(2)** other than those stated in B.3., which are adequately covered by general experience, welder's qualification tests and approved welding consumables,
- Single-side welding on ceramic, flux or similar backings,
- Welding in the vertical-down position.

**1.4** For conventional single-wire submerged-arc butt welding processes using solid wire for welding normal-strength hull structural steels A to D, comparable structural steels, forged steels and cast steels from both sides, proof prior to initial use of the reliability and technical suitability of the method by means of trial welds and non-destructive (e.g. radiographic) tests as directed by the Surveyor is sufficient. The welding consumables and auxiliary materials used must have been approved by **TL**.

**1.5** **TL** may additionally require welding procedure tests for specific (difficult) component shapes or combinations of materials, environmental conditions (e.g. underwater welding), particular weld shapes, process variants or combinations, and also for particular welding consumables and auxiliary materials. The same applies in analogous manner to other joining processes or (surface) finishing operations such as thermal cutting or flame straightening.

**1.6** The information in the preceding and following paragraphs, especially the information on test pieces, specimen shapes, tests and requirements, applies to the normal materials, welding processes and weld shapes in current use in shipbuilding, the behaviour of which under service conditions has been verified by experience and/or test results. In cases of doubt, **TL** may call for additional and/or different test pieces,

specimen shapes or tests to verify satisfactory suitability for use.

**1.7** In the case of welding processes whose characteristics result in weld shapes other than those verified by experience and/or test results (e.g. those with a considerable notch effect), the influence of the weld shape on the fatigue strength behaviour of the welded joints may be investigated in addition to carrying out the prescribed tests. The same applies in analogous manner to other characteristics of the welded joints, e.g. corrosion resistance.

## **1.8 Welding procedure specification**

**1.8.1** A welding procedure specification (WPS) is to be prepared by the shipyard or manufacturer which intends to perform the welding procedure test. This document is also referred to as a preliminary welding procedure specification (pWPS). The pWPS can be modified and amended during procedure tests as deemed necessary however it is to define all relevant variables as mentioned in the WPS (refer to ISO 15614 or other recognized standards).

**1.8.2** The shipyard or manufacturer is to submit to the Society a pWPS for review prior to the tests. In case that the test pieces welded according to the pWPS show unacceptable results the pWPS is to be adjusted by the shipyard or manufacturer. The new pWPS is to be prepared and the test pieces welded in accordance with the new pWPS.

**1.8.3** The WPS is to be used as a basis for the production welds, and upon satisfactory completion of the tests based on the pWPS; the Society may approve it as a WPS. In case that a WPS is approved by the Society the approval range is to be as given in this section.

## **1.9 Qualification of welding procedures**

**1.9.1** Preparation and welding of test pieces are to be carried out in accordance with the pWPS and under the general condition of production welding which it represents.

**1.9.2** Welding of the test assemblies and testing of

test specimens are to be witnessed by the Surveyor.

**1.9.3** If tack welds and/or start and stop points are a condition of the weld process they are to be fused into the joint and are to be included in the test assemblies.

## **2. Scope of tests, test schedule, limits of application and range of approval**

### **2.1 Test schedule, test details**

**2.1.1** The scope of the welding procedure tests (test pieces, specimens, tests) shall be laid down in a test schedule to be submitted for approval in good time prior to testing, in accordance with Section 4. Depending on

#### **(1) Materials:**

*Normal-strength hull structural steels E and F, higher-strength hull structural steels and comparable grades of forged steels or steel castings, high-strength (quenched and tempered) fine grained structural steels, steels tough at subzero temperatures, stainless and clad steels, aluminium alloys and other non-ferrous metals.*

#### **(2) Welding Processes:**

##### **Manual welding processes:**

*Vertical-down welding, deep penetration welding, single-side welding with backing, etc.*

##### **Semi-mechanized welding processes:**

*Gravity arc or auto-contact welding, single-side welding with backing, flux-cored wire metal-arc welding without shielding gas, etc.*

##### **Fully-mechanized welding processes:**

*Submerged arc welding, fusarc and flux-cored wire metal-arc welding, multiple-electrode submerged arc welding, single-side welding, fillet and double-fillet welding, electroslag welding with and without fusible wire guide nozzle electrode(s), gas-shielded metal-arc welding, electrogas welding etc.*

##### **Special welding processes or special applications:**

*Stud welding, flash butt welding, friction welding, laser-beam welding, build-up welding, orbital welding of circumferential pipe welds, robot welding, etc*

the nature and application of a welding process, the process details stipulated in Section 4, B.1.1 shall be taken into account in the tests. Where no further details on the welding procedure tests are given in the following paragraphs, the provisions of Section 4 and the standards of the series ISO15607 shall apply.

**Note:**

*The following rules relating to the welding procedure tests comply with, borrow from in part or refer to the standards of the series ISO 15607. Compared with the previous versions of these Rules for Welding, all the details relating to the welding procedure tests which, from the shipbuilding aspect, have been satisfactorily covered in the standards, are no longer contained in these Rules or only by reference to these standards, especially to ISO 15614-1 "Specification and qualification of welding procedures for metallic materials – Welding procedure test – Part 1: Arc and gas welding of steels and arc welding of nickel and nickel alloys" and ISO 15614-2 " Specification and qualification of welding procedures for metallic materials – Welding procedure test – Part 2: Arc welding of aluminium and its alloys"*

*Details specific to shipbuilding, such as material groupings, single-side welding or the inclusions and exclusions for welding positions (vertical-down welding) requiring special and specific experience and proven manipulation and which are only inadequately covered in the standards are dealt with in the following paragraphs as a departure from the standards. Under the provisions of the regulations applicable to other ranges of application (e.g. for pressure equipment), the Rules issued by **TL** for shipbuilding shall be regarded as the predominant codes of practice.*

**2.1.2** Depending on the nature of the base material or the influence of the characteristics of the process **TL** may set out specifications which go beyond or deviate from the stipulations given in these rules or in the standards and call for different or additional tests, stipulate requirements or change the scope of application. **TL** also reserves the right to interpret the standards accordingly. Where the standards contain information which is different from or contradicts these rules, these rules shall take precedence.

**2.1.3** All the conditions of validity stated below are to be met independently of each other.

**2.1.4** Changes outside of the ranges specified are to require a new welding procedure test.

**2.1.5** Shop primers may have an influence on the quality of fillet welds and is to be considered. Welding procedure qualification with shop primer will qualify those without but not vice versa.

**2.2 Base materials, material groups**

**2.2.1** The welding procedure test shall in principle be carried out by welding the base materials for which application for approval was made. Except for hull structural steels and austenitic-ferritic duplex steels, the base materials for the welding procedure tests may be grouped into material groups in accordance with the standards of the series ISO15607 and the test performed using representative materials from this groups. The provisions set out in the following paragraphs apply to hull structural steels. Duplex steels are regarded as an independent material group and are not covered by the group of austenitic stainless steels

**Note:**

*CEN report CRI2187 (shortly to be available in a revised version as European standard CR TR 15608 or as ISO standard) classifies weldable materials (for general use) into categories with comparable, identifying properties. These categories are finely graded to include in addition special properties such as the behaviour of materials during heat treatment.*

*Austenitic stainless steels and austenitic-ferritic stainless steels are therefore classified into different groups. In preference to the rough classification favoured by the standards of the series ISO15607 (the same applies in analogous manner to the welder's qualification tests conforming to EN 287/ISO 9606), it is therefore advisable to use the classification given in CEN report I2187 or the anticipated follow-on standards. **TL** may stipulate this.*

**2.2.2** If a welding procedure test is to be carried out for several base materials simultaneously, materials which cover both the various strength categories (...-, ...32, ...36, ...40) and the various degrees of toughness (A/A..., B, D/D..., E/E..., F...) shall be selected for hull structural steels, taking the wall thicknesses into account. The same procedure shall apply in analogous manner to other materials.

**2.2.3** Based on their chemical composition (behaviour during welding) and their mechanical characteristics the various hull structural steels may be classified or, as the case may be, grouped into the following three (strength) categories:

- Normal-strength hull structural steels A, B, D and E (includes comparable, general structural steels, forged steels and cast steels with minimum yield strengths up to 280 N/mm<sup>2</sup>),
- Higher-strength hull structural steels A 32, D 32, E 32, F 32, A 36, D 36, E 36 and F 36 (includes comparable general-purpose structural steels with minimum yield strengths of over 280 N/mm<sup>2</sup> up to and including 355 N/mm<sup>2</sup>),
- Higher-strength hull structural steels A 40, D 40, E 40, F 40 (includes comparable, general-purpose structural steels with minimum yield strengths of over 355 N/mm<sup>2</sup> up to and including 390 N/mm<sup>2</sup>).

**2.2.4** The following conditions apply to the selection of materials:

**2.2.4.1 Normal and higher strength hull structural steels according to UR W11 (Chapter 2 - Material, Section 3, B)**

**2.2.4.1.1** For each strength level, welding procedures are considered applicable to the same and lower toughness grades as that tested.

**2.2.4.1.2** For each toughness grade, welding procedures are considered applicable to the same and two lower strength levels as that tested.

**2.2.4.1.3** For applying the 2.2.4.1.1 and 2.2.4.1.2 to high heat input processes above 50kJ/cm, e.g. the two run technique with either submerged arc or gas shielded metal arc welding, electro slag and electro gas welding, welding procedure is applicable to that toughness grade tested and one strength level below.

Where steels used for construction are supplied from different delivery conditions from those tested **TL** may require additional tests.

**2.2.4.2 High strength quenched and tempered steels according to UR W16 (Chapter 2 - Material, Section 3, C)**

**2.2.4.2.1** For each strength level, welding procedures are considered applicable to the same and lower toughness grades as that tested.

**2.2.4.2.2** For each toughness grade, welding procedures are considered applicable to the same and one lower strength level as that tested.

**2.2.4.2.3** The approval of quenched and tempered steels does not quality thermo-mechanically rolled steels (TMCP steels) and vice versa.

**2.2.4.3 Weldable C and C-Mn hull steel forgings according to UR W7 (Chapter 2 - Material, Section 5)**

**2.2.4.3.1** Welding procedures are considered applicable to the same and lower strength level as that tested.

**2.2.4.3.2** The approval of quenched and tempered hull steel forgings does not quality other delivery conditions and vice versa.

**2.2.4.4 Weldable C and C-Mn hull steel castings according to UR W8 (Chapter 2 - Material, Section 6)**

**2.2.4.4.1** Welding procedures are considered applicable to the same and lower strength level as that tested.

**2.2.4.4.2** The approval of quenched and tempered hull steel castings does not quality other delivery conditions and vice versa.

**2.2.5** If the range of application of a welding procedure encompasses several steels belonging to one strength category or one group of degrees of toughness, the welding procedure test shall be performed on at least two steels from each strength category or each degree of toughness, as applicable. Of these, one shall represent the lowest category or degree and one the highest category or degree.

**2.2.6** However, **TL** may, when testing several base materials at the same time, dispense with testing certain steels if their influence on the quality of the welded

joints is adequately covered by the tests of the other steels (in combination with the various test piece thicknesses if necessary). Some examples of material selection (without taking into account specific process characteristics or as-delivered conditions of materials) are shown in Table 12.2.

**2.2.7** Where the characteristics of the process or the base materials have no appreciable influence on the test results due to the shape of the test piece or specimen or the tests performed, **TL** may agree to a restriction to a few base materials or only to one. An example of this is the testing of the fillet welding process using cruciform tensile specimens, macrographic specimens and hardness measurements; in this case it is sufficient to perform the test on steel from the highest strength category intended for the application and with the maximum possible carbon equivalent.

### **2.3 Thicknesses of test pieces, range of wall thicknesses**

**2.3.1** The thicknesses of the test pieces shall be geared to the range of application and the welding process in such a way as to comply with the conditions specified in Table 12.3. As a general rule, test pieces of at least two different thicknesses shall be welded and tested for each range of application according to Table 12.2 (each base material group). For vertical-down welding, the upper thickness limit for the intended range of application shall be used for the thickness of the test piece

**2.3.2** In conjunction with the test piece thicknesses stated in paragraph 2.3.1, (see also 3.2), the throat thicknesses "a" of fillet welds shall be established such that the approval range from "0,75a" to "1,5a" covers the desired range of application for single run. The throat thicknesses for the test piece shall therefore be selected so that the "a" dimension roughly equals half the thickness of the test piece (half the thickness of the thinner plate where the thicknesses of the plate are unequal). For (test piece) throat thicknesses of 10 mm or more, a range of application  $a > 10$  mm applies.

*Note: For multi run applications the approval range as taken as for butt welds with multi run (i.e.  $a=t$ ).*

**2.3.3** Where, for subsequent use, relatively thin fillet

welds are to be applied to very thick components (see G.10.3.3), similar test pieces are to be welded and examined for hot cracking, underbead cracks or hardening cracks. This requirement is specially applicable to higher- and high-strength grades of steel and cast steel.

**2.3.4** For the reduction of the specified fillet weld throat thicknesses where specially deep penetration is proved, see G.10.3.5. With regard to the increase of the "a" dimension when overweldable shop primers which are particularly liable to cause porosity or processes with inadequate root penetration are used, see G.10.3.6.

**2.3.5** Where a fillet welding process is to be applied to plates or sections coated with overweldable shop primer, similarly coated plates are to be used for the fillet weld test pieces required for the welding procedure test. The type and thickness of the coating of shop primer shall be stated in the test report.

### **2.4 Welding process**

**2.4.1** The approval is only valid for the welding process(es) used in the welding procedure test. It is not permitted to change from a multi-run to a single run.

**2.4.2** For multi-process procedures the welding procedure approval may be carried out with separate welding procedure tests for each welding process. It is also possible to make the welding procedure test as a multi-process procedure test. The approval of such a test is only valid for the process sequence carried out during the multi-process procedure test.

### **2.5 Welding consumable**

Except high heat input processes over 50kJ/cm, welding consumables cover other approved welding consumables having the same grade mark including all suffixes specified in UR W17 (Chapter 3 - Welding, Section 5 and Section 12, E) and UR W23 (Chapter 3 - Section 5, F) with the welding consumable tested.

### **2.6 Heat input**

**2.6.1** The upper limit of heat input approved is 25%

**Table 12.2 Base material categories (hull structural steels, examples)**

Range of application	Base material
Quality grades A ve B	A or B
Quality grades A - D	A and D
Quality grades A - E	A and E
Quality grades A32 - D36	A36 and D36
Quality grades A32 - E36	A36 and E36
Quality grades A32 - F36	A36 and F36
Quality grades A40 - D40	A40 and D40
Quality grades A40 - E40	A40 and E40
Quality grades A40 - F40	A40 and F40
Quality grades A - D ve A32 - D36	A, D and D36 or A, A36 and D36
Quality grades A - E ve A32 - E36	A, D and E36 or A, E and E36 or A, A36 and E36

**Table 12.3 Test piece thickness**

Test piece thickness (1), (2) t [mm]	Range of application (4) (5) (6)	
	Single-run welding (single bead) and welding in one run on each side (Two-run technique)	Multi run technique (3)
t ≤ 3	0,8 t - 1,1 t	1t - 2 t
3 < t ≤ 12	0,8 t - 1,1 t (7)	3 mm. - 2 t
12 < t ≤ 100	0,8 t - 1,1 t	0,5t - 2 t, (max. 150 mm)
t > 100	0,8 t - 1,1 t	0,5 t - 1,5 t

(1) If special cooling conditions have to be complied with or particular weld shapes are prescribed, they shall be taken into account when selecting the test piece thickness.

(2) For multi process procedures, the recorded thickness contribution of each process is to be used as a basis for the range of approval for the individual welding process.

(3) For fillet welds, the range of approval is to be applied to both base metals.

(4) For unequal plate thicknesses the following applies:  
For butt welds, the average of the two plate thicknesses in the weld area ~ weld thickness is the ruling dimension. For fillet weld joints, the lower limit of the range of application of 0,8 times the smaller test piece thickness  $t_1$  (e.g. web thickness) and the upper limit of 1,1 times the larger test piece thickness  $t_2$  (e.g. flange thickness) is the ruling dimension, but the ratio of plate thicknesses  $t_2$  to  $t_1$  shall not exceed 3.

(5) For the vertical-down welding, the test piece thickness  $t$  is always taken as the upper limit of the range of application.

(6) Notwithstanding the above, the approval of maximum thickness of base metal for any technique is to be restricted to the thickness of test assembly if three of the hardness values in the heat affected zone are found to be within 25 HV of the maximum permitted, as stated (2) and (3).

(7) For high heat input processes over 50kJ/cm, the upper limit of range of approval is to be 1.0 x t.



greater than that used in welding the test piece or 55kJ/cm whichever is smaller, except that the upper limit is 10% greater than that for high heat input processes over 50kJ/cm.

**2.6.2** The lower limit of heat input approved is 25% lower than that used in welding the test piece.

## 2.7 Preheating and interpass temperature

**2.7.1** The minimum preheating temperature is not to be less than that used in the qualification test.

**2.7.2** The maximum interpass temperature is not to be higher than that used in the qualification test.

## 2.8 Post-weld heat treatment

The heat treatment used in the qualification test is to be maintained during manufacture. Holding time may be adjusted as a function of thickness.

## 2.9 Type of joint

**2.9.1** Range of approval depending on type of welded joints for test assembly is to be specified in Table 12.4.

**Table 12.4 Range of approval for type of welded joint**

Type of welded joint for test assembly				Range of approval
Butt welding	one side	with backing	A	A, C
		without backing	B	A, B, C, D
	both side	with gouging	C	C
		without gouging	D	C, D

**2.9.2** A qualification test performed on a butt weld will also qualify for fillet welding within the thickness ranges specified for fillet welds specified in 5.3 above.

## 2.10 Other variables

The range of approval relating to other variables may be taken according to the TL requirements.

## 2.11 Re-testing

**2.11.1** If the test piece fails to comply with any of the requirements for visual or non-destructive testing one further test piece is to be welded and subjected to the same examination. If this additional test piece does not comply with the relevant requirements, the pWPS is to be regarded as not capable of complying with the requirements without modification.

**2.11.2** If any test specimens fail to comply with the relevant requirements for destructive testing due to weld imperfections only, two further test specimens are to be obtained for each one that failed. These specimens can be taken from the same test piece if there is sufficient material available or from a new test piece, and are to be subjected to the same test. If either of these additional test specimens does not comply with the relevant requirements, the pWPS is to be regarded as not capable of complying with the requirements without modification.

**2.11.3** If a tensile test specimen fails to meet the requirements, the re-testing is to be in accordance with UR W 2.4.3 (Chapter 2 - Material, Section 2, B.3) 4.4.4 If there is a single hardness value above the maximum values allowed, additional hardness tests are to be carried out (on the reverse of the specimen or after sufficient grinding of the tested surface). None of the additional hardness values is to exceed the maximum hardness values required.

**2.11.4** The re-testing of Charpy impact specimens are to be carried out in accordance with UR W 2.7.4.

**2.11.5** Where there is insufficient welded assembly remaining to provide additional test specimens, a further assembly is to be welded using the same procedure to provide the additional specimens.

## 2.12 Test record

**2.12.1** Welding conditions for test assemblies and test

results are to be recorded in welding procedure test record. Forms of welding procedure test records can be taken from the Society's rules or from relevant standards.

**2.12.2** A statement of the results of assessing each test piece, including repeat tests, is to be made for each welding procedure test. The relevant items listed for the WPS of these requirements are to be included.

**2.12.3** A statement that the test piece was made according to the particular welding procedure is to be signed by the Surveyor witnessing the test and is to include TL's identification.

### 3. Test pieces, dimensions, direction of rolling, welding positions

#### 3.1 Shape and size of test pieces, direction of rolling

**3.1.1** Unless other provisions are given in the paragraphs below, the shape and size of test pieces shall be selected in accordance with the series of standards ISO 15607. The length of the test pieces shall be appropriate for the welding process and the number of specimens. Where scheduled in the fabrication work for the particular welding process in question, both butt-weld and fillet-weld test pieces shall be made.

For hull structural steel plates impact tested in the longitudinal direction (CVN-L) in UR W11 (Chapter 2 - Material, Section 3, B), the butt weld of the test piece is perpendicular to the rolling direction of the two plates.

For high strength quenched and tempered steel plates impact tested in the transverse direction (CVN-T) in UR W16 (Chapter 2 - Material, Section 3, C), the butt weld of the test piece is parallel to the rolling direction of the two plates.

**3.1.2** For butt welding, the test assembly is to be of a size sufficient to ensure a reasonable heat distribution and according to Figure 12.2 with the minimum dimensions:

- Manual or semi-automatic welding:  
width =  $2a$ ,  $a = 3 \times t$ , min 150 mm  
length  $b = 6 \times t$ , min 350 mm

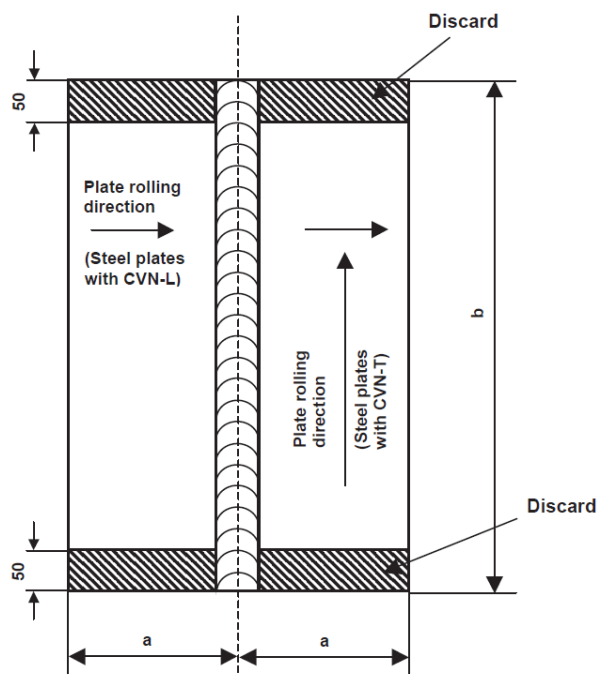

**Figure 12.1** Test assembly for butt weld

- Automatic welding:  
width =  $2a$ ,  $a = 4 \times t$ , min 200 mm  
length  $b = 1000$  mm

**3.1.3** For welding in (clamping) jigs, the size of the test piece shall conform to the size of the jig. For single-side welding processes and the fully mechanized and/or automatic double fillet welding (e.g. for stiffeners on platings), the test piece shall be at least 3000 mm long.

**3.1.4** In the case of vertical welding, the length of the test piece (the weld length) shall conform to the size of the jig used in fabrication. For jigs using a fusible wire-guide electrode, the length of the test piece shall conform to the length of the wire-guide electrode or the height of the components to be welded. Any special features affecting the application of these processes (e.g. welding operations performed through the deck) shall be allowed for in the configuration of the test piece.

**3.1.5** Where, in order to establish the mechanical and technological characteristics of the welded joints, especially in fully mechanized and/or automatic welding processes, test piece lengths are selected which are considerably smaller than the weld lengths to be laid down during later fabrication, the first fabrication welds shall be included as part of the welding procedure tests and, as a minimum requirement, shall be subjected to a

visual inspection and non-destructive testing to ensure a trouble-free welding procedure and to detect any imperfections in the weld.

### 3.2 Fillet-weld test pieces (T-joint and/or double T-joint (cruciform) test pieces)

**3.2.1** Fillet-weld test pieces (T-joint and double T-joint (cruciform) test pieces) shall be joined with air gaps not greater than 0,5 mm. Depending on subsequent practice, tacks shall also be included in the test (and overwelded where applicable). The throat thickness of the fillet welds should correspond to those used in subsequent fabrication but should not be greater than  $0,5 \times$  plate thickness (see 2.3.2 to 2.3.4). For shop primers, see 2.3.5.

**3.2.2** For T-joint fillet welding, the test assembly is to be of a size sufficient to ensure a reasonable heat distribution and according to Figure 12.2 with the minimum dimensions:

- manual and semi-automatic welding:  
width  $a = 3 \times t$ , min. 150 mm

length  $b = 6 \times t$ , min. 350 mm

- automatic welding:  
width  $a = 3 \times t$ , min. 150 mm  
length  $b = 1000$  mm

**3.2.3** Double T-joint test pieces as shown in Figure 12.3 or Figure 12.4 (cruciform test pieces) are always required when the welding procedure test relates to vertical-down welding or to the welding of high-strength steels with minimum yield strengths over  $460 \text{ N/mm}^2$ , clad plates and non-ferrous metals. The Society may also require cruciform test pieces for other processes and/or materials.

The throat thickness of the fillet weld "a" shall not exceed 0,5 times the plate thickness.

**3.2.4** In order to simplify the process where the test pieces are broken open on alternate sides, welding may be performed on one side only of the double T-joint (cruciform) test pieces on alternate sides in the fracture area, in analogous manner to the stipulations of the codes of practice DVS 1702

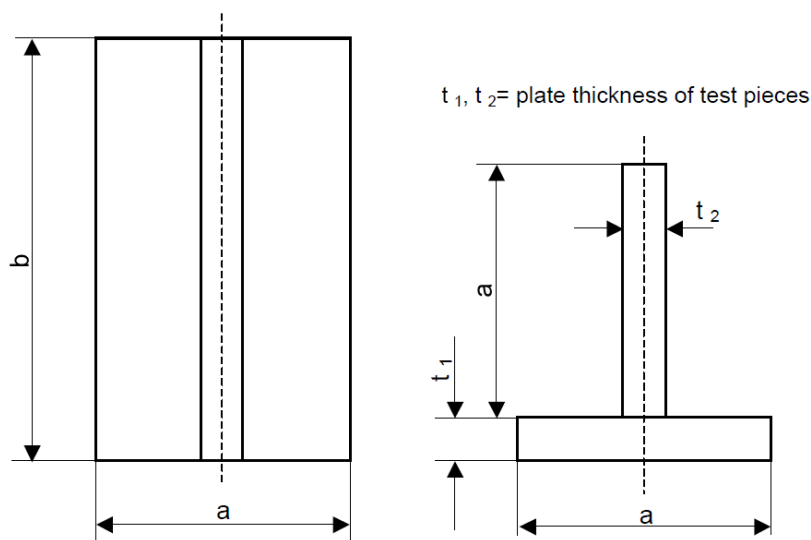
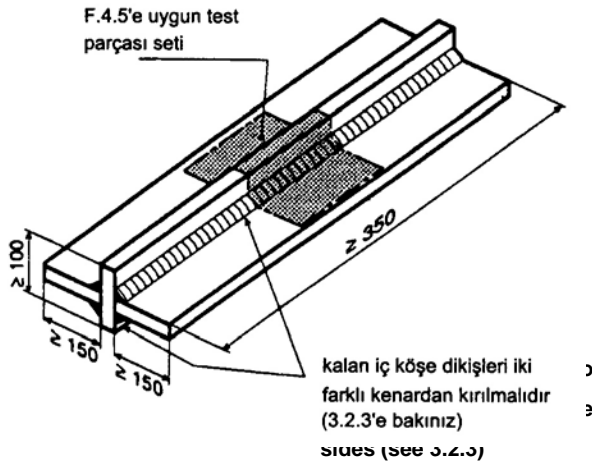
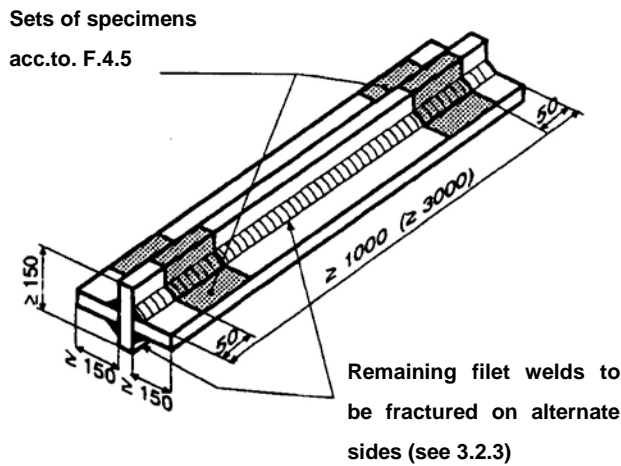

Figure 12.2 Test assembly for fillet weld in welding positions PA, PB, PD, PF



**Figure 12.3 Double T-joint (cruciform) test piece for manual and semi-mechanized welding processes**



**Figure 12.4 Double T-joint (cruciform) test piece for fully mechanized welding processes**

**3.2.5** The test assembly is welded on one side only. For single run manual and semi-automatic welding, a stop / restart is to be included in the test length and its position is to be clearly marked for subsequent examination.

### 3.3 Weld shapes, welding positions, heat treatment, non-destructive testing

**3.3.1** Weld forms which may differ in their manner of joining (e.g. butt weld or T-joint) and plate thickness shall be included in the test. Where weld forms, welding parameters and run build-up (e.g. in submerged-arc welding from square butt weld via single-V butt weld to double-V butt weld) are changed during a welding process within the range of application for which application for approval is made, these "shifts" in

procedure shall also be allowed for by means of appropriate test pieces.

**3.3.2** T-joints with full penetration welded single-bevel or double-bevel butt joints are normally regarded as butt joints, i.e. they are covered by the butt weld test pieces. For welds with incomplete penetration and for special weld forms (e.g. the deep, acute-angled open single-V butt welds used in branch pieces) the Society may, however, call for additional test pieces to at least verify adequate weld penetration and penetration conditions.

**3.3.3** Test pieces are normally welded in all the conventional welding positions (for which application for approval is made). To qualify a range of positions, test assemblies are to be welded for highest heat input position and lowest heat input position and all applicable tests are to be made on those assemblies. For single-side welding, a test piece which has been welded in the PC (h-v) position must always be provided. For information on the welding procedure for the test pieces, any post-weld heat treatment or other finishing work which may be required and the non-destructive tests; see the corresponding provisions in Section 4, B.

## 4. Sets of specimens, test specimens, mechanical and technological tests

### 4.1 Set of test specimens for butt welds - general provisions

For standard manual and semi-mechanized welding, one set of test specimens shall be taken from the butt-welded test pieces in accordance with the above-mentioned standards. For fully-mechanized and/or automatic welding, at least one set each shall be taken from the start and end of the weld, see Section 4, B.8.3. The division of the test pieces into sections (preparation of specimens, marking) and the performance of the mechanical and technological tests, etc. shall be carried out in accordance with Section 11 as applicable.

Unless otherwise agreed in a particular case, one set of butt weld specimens shall comprise the following specimens. The specimen shapes and dimensions shall conform to the provisions of the IACS URs (as a minimum), standards or Section 11 as applicable

Test assemblies are to be examined non-destructively and destructively in accordance with the following and Figure 12.5:

- Visual testing 100 %
- Surface crack detection 100 %  
(dye penetrant testing or magnetic particle testing)
- Radiographic or Ultrasonic testing 100 %
- Transverse tensile test two specimens as in 4.1.1.1
- Longitudinal tensile test required as in 4.1.1.2
- Transverse bend test four specimens as in 4.1.2
- Charpy V-notch impact test required as in 4.1.3
- Macro examination one specimen as in 4.1.4

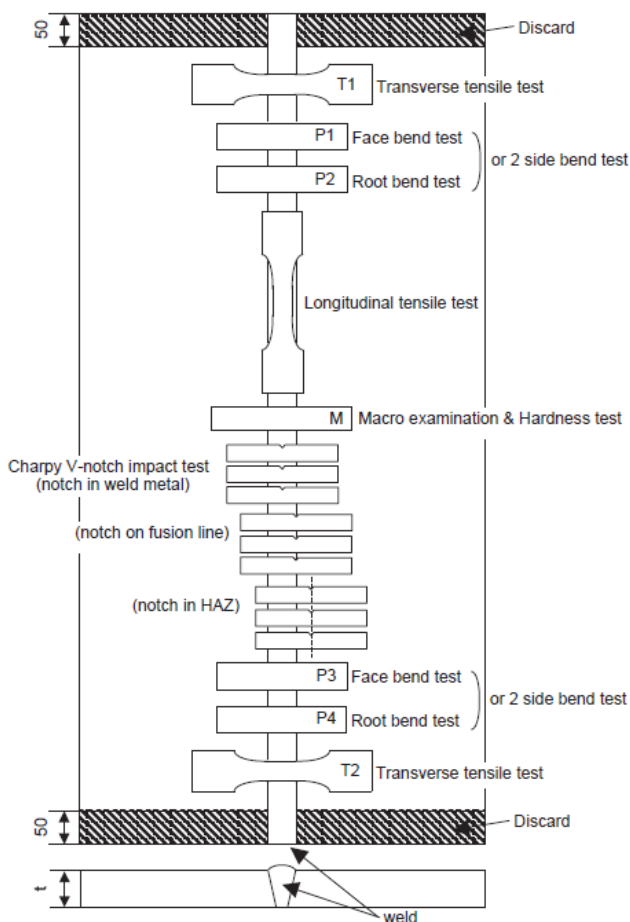

Figure 12.5 Test sampling

*Note: Test assemblies are to be examined by visual and by non-destructive testing prior to the cutting of test specimen. In case that any post-weld heat treatment is required or specified, non-destructive testing is to be performed after heat treatment. For steels according to UR W16 (Chapter 2 - Material, Section 3, C) with specified minimum yield strength of 420 N/mm<sup>2</sup> and above the non-destructive testing is to be delayed for a minimum of 48 hrs, unless heat treatment has been carried out. NDT procedures are to be agreed with TL.*

*Imperfections detected by visual or non-destructive testing are to be assessed in accordance with ISO 5817, class B, except for excess weld metal and excess of penetration for which the level C applies.*

#### 4.1.1 Tensile Tests

##### 4.1.1.1 Transverse tensile test (2 transverse tensile test specimens)

The testing is to be carried out in accordance with UR W2.4 (Chapter 2 - Material, Section 2, and B.1) (as a minimum) and ISO 4136. The tensile strength recorded for each specimen is not to be less than the minimum required for the base metal.

When butt welds are made between plates of different grades, the tensile strength to be obtained on the welded assembly is to be in accordance with the requirements relating to the steel grade having lower strength.

For larger plate thicknesses a correspondingly greater number of specimens shall be provided to cover the full cross-section,

##### 4.1.1.2 Longitudinal tensile test (1 round tensile test specimen)

Longitudinal tensile test of deposited weld metal taken lengthways from the weld is required for cases where the welding consumable is not approved by TL or if the characteristics of the welding process suggest that the weld metal itself is likely to be considerably affected.

A round tensile test specimen is to be prepared in every case (except for aluminium alloys) where the mechanical properties of the weld metal are inferior to

those of the base material (e.g. when welding high-strength steels). The diameter " $d_0$ " of the specimen shall be as large as possible (but not more than 10 mm) and the gauge length " $L_0$ " shall be  $5 \times d_0$ . The provisions of Section 5, B.2. are to be applied in analogous manner.

The testing is to be carried out in accordance with UR W2.4 (Chapter 2 - Material, Section 2, B.1). The tensile properties recorded for each specimen are not to be less than the minimum required for the approval of the appropriate grade of consumable.

Where more than one welding process or type of consumable has been used to make the test weld, test specimens are to be taken from the area of the weld where each was used with the exception of those processes or consumables used to make the first weld run or root deposit.

#### 4.1.2 Bend Tests

Transverse bend tests for butt joints are to be in accordance with UR W2.6 (Chapter 2 - Material, Section 2, C) (as a minimum, standards referred to in following items are to be complied with).

The mandrel diameter to thickness ratio (i.e.  $D/t$ ) is to be that specified for the welding consumable UR W17 (Section 5 and Section 12, E), UR W23 (Section 5, F), approvals.

The bending angle is to be  $180^\circ$ . After testing, the test specimens are not to reveal any open defects in any direction greater than 3 mm. Defects appearing at the corners of a test specimen during testing are to be investigated case by case.

- **4 transverse bend test specimens**, in accordance with ISO 5173 half to be bent with the final pass in tension (FBB) and half with the root pass in tension (RBB),  
or
- **2 transverse bend test specimens** as before and **2 side bend test specimens** taken at right angles to the butt weld (SBB) in accordance with ISO 5173 in the case of test pieces over 12 mm thick

or:

- **4 side bend test specimens (SBB)** in the case of test pieces 20 mm thick and welding processes liable to give rise to segregations, lack of fusion or similar defects inside the weld (e.g. single-side and vertical-down welding).

#### Note:

*In the case of pairs of materials which differ in strength, it may be advisable to use butt-welded longitudinal bend test specimens (FBB and RBB) in accordance with (ISO 5173) with the weld seam in the centre of the specimen instead of butt-welded transverse bend test specimens. See also Section 11. The details of this test and the requirements (as a rule a qualitative assessment of the bending behaviour) shall be agreed on a case-by-case basis.*

#### 4.1.3 Impact Tests

##### 4.1.3.1 Normal and higher strength hull structural steels according to UR W11 (Chapter 2 - Material, Section 3, B),

The positions of the specimens are to be in accordance with these requirements. Dimensions and testing are to be in accordance with the requirements of UR W2.7

Test specimen with Charpy-V-notch are to be used and sampled from 1 to 2 mm below the surface of the base metal, transverse to the weld and on the side containing the last weld run.

V-notch specimens are located in the butt-welded joint as indicated in Figure 12.6 and 12.7

Test temperature and absorbed energy are to be in accordance with Table 12.5 When butt welds are made between different steel grades/types, the test specimens are to be taken from the side of the joint with lower toughness of steel. Temperature and absorbed energy results are to be in accordance with the requirements for the lower toughness steel.

Where more than one welding process or consumable has been used to make the test weld, impact test specimens are to be taken from the respective areas where each was employed.

This is not to apply to the process or consumables used solely to make the first weld run or root deposit.

The testing of sub-size specimen is to be in accordance with UR W2.7.2 (Chapter 2 - Material, Section 2, D. Table 2.3),

- **3 notched bar impact test specimens each** (Charpy V-notch specimens with the notch perpendicular to the surface of the plate) in accordance with UR W2.7 (as a minimum) and ISO 9016, from the centre of the weld (VWT 0/1), from the fusion boundary/transition zone (VHT 0/1) and from the heat-affected zone (VHT 2/1). The notched bar impact test specimens shall be taken from the last side welded, and with larger plate thicknesses they shall be taken from both sides. With very large plate thicknesses and welding processes liable to

cause segregation in the central zone, an additional **3 notched bar impact test specimens** of each type shall be taken from the same areas in middle of the plate thickness.

The dimension "a" (see ISO 9016) shall be such that the point of intersection of the centre line of the specimen and the middle of the notch lies in the coarse-grained area of the heat-affected zone. This dimension may be generally taken as 2 mm. Where welding procedure tests are performed on steels tough at subzero temperatures, test specimens with notches located at  $a = 1$  mm,  $a = 3$  mm and  $a = 5$  mm shall be prepared, unless otherwise specified in an individual case.

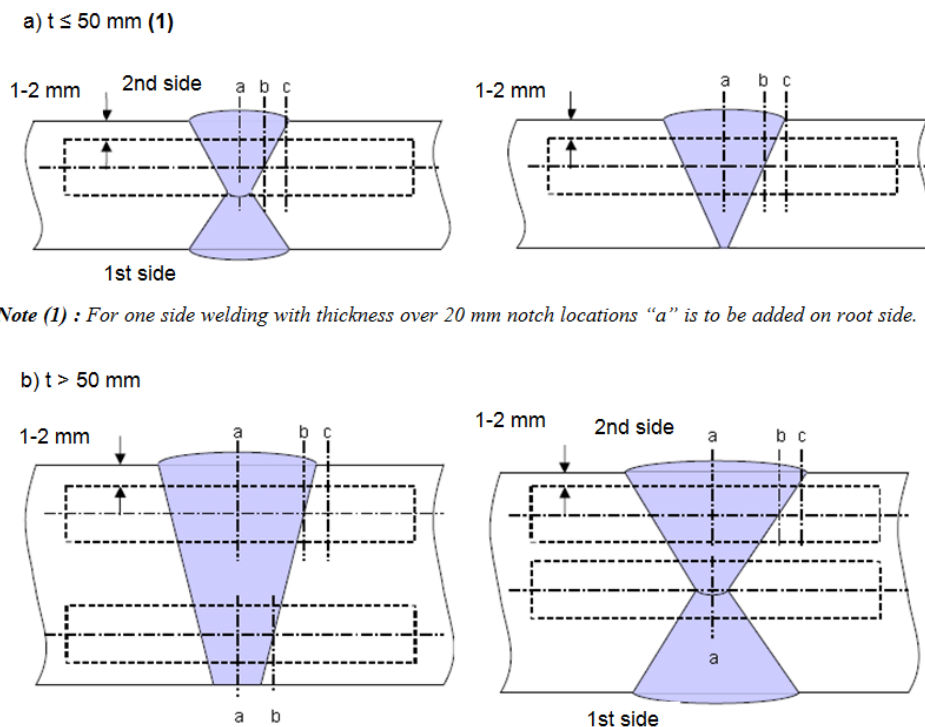

Notch locations:

- a : Center of weld "WM"
- b : On fusion line "FL"
- c : In HAZ, 2mm from fusion line

Figure 12.6 Locations of V-notch for butt weld of normal heat input (heat input  $\leq 50$  KJ/cm)

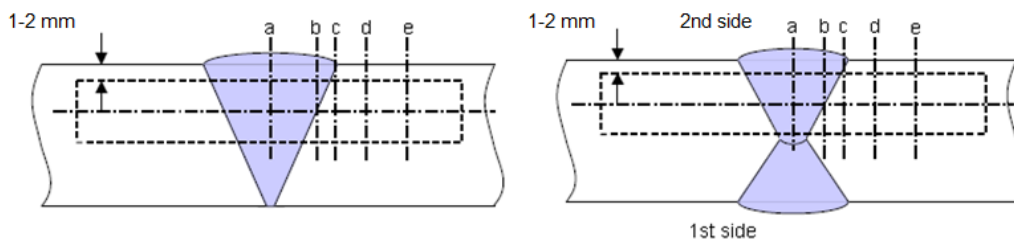
a)  $t \leq 50$  mm (1)

*Note (1) : For one side welding with thickness over 20 mm notch locations "a", "b" and "c" are to be added on root side.*

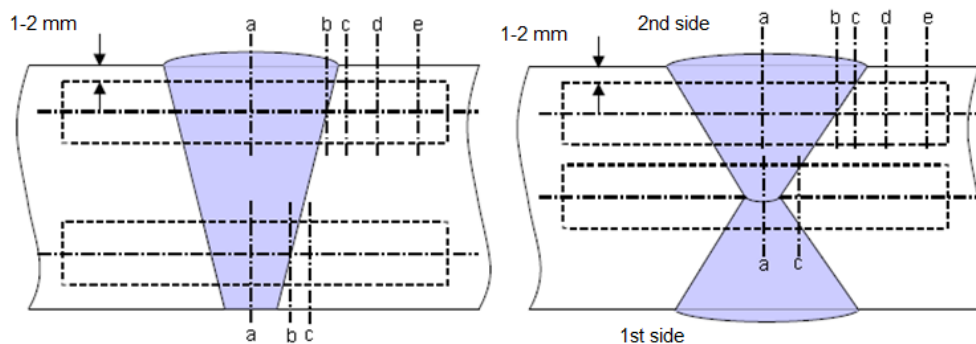
b)  $t > 50$  mm

Notch locations:

- a : Center of weld "WM"
- b : On fusion line "FL"
- c : In HAZ, 2mm from fusion line
- d : In HAZ, 5mm from fusion line
- e : In HAZ, 10mm from fusion line in case of heat input > 200kJ/cm

**Figure 12.7 Locations of V-notch for butt weld of high heat input (heat input > 50 KJ/cm)**

Depending on the base material and welding process concerned, further notched bar impact test specimens from other areas may be stipulated. Notched bar impact test specimens may be partly or wholly dispensed with where the results of these tests in connection with the use of a particular welding process are of minor significance for certain materials (e.g. austenitic stainless steels or aluminium alloys, except for low-temperature applications)

#### 4.1.3.2 High strength quenched and tempered steels according to UR W16

Impact test is to be performed as described in the above a

#### 4.1.3.3 Weldable C and C-Mn hull steel castings and forgings according to UR W7 (Chapter 2 - Material, Section 5) and UR W8 (Chapter 2 - Material, Section 6).

For base metal with specified impact values test temperature and absorbed energy are to be in accordance with the requirements of the base metal to be welded.

#### 4.1.4 Macrographic tests

2 macrographic (if necessary, micrographic) specimens for evaluating the grain structure.

The test specimens are to be prepared and etched on



one side to clearly reveal the weld metal, the fusion line and the heat affected zone.

Macro examination is to include about 10 mm unaffected base metal.

The examination is to reveal a regular weld profile, through fusion between adjacent layers of weld and base metal and the absence of defects such as cracks, lack of fusion etc.

#### 4.1.5 Hardness tests

Vickers HV5 or HV10 (the Vickers method HV 10 is normally to be used) in accordance with EN ISO 9015-1(EN ISO 9015-2 in the case of laser welding) shall be carried out where, having regard to the base material and the welding process, the possibility cannot be discounted that preheating and/or the heat flow during welding may affect the hardness values in such a way as to impair the toughness or strength characteristics of the weld. Hardness measurements shall always be performed on higher-strength hull structural steels and on high-strength (quenched and tempered) fine-grained structural steels with minimum yield strengths of more than 355 N/mm<sup>2</sup>.

The indentations are to be made in the weld metal, the heat affected zone and the base metal measuring and recording the hardness values. At least two rows of indentations are to be carried out in accordance with Figure 12.8 and 12.9

For each row of indentations there is to be a minimum of 3 individual indentations in the weld metal, the heat affected zones (both sides) and the base metal (both sides). A typical example is shown in Figure 12.8,12.9, 12.10a, 12.10.b, 12.11.a and 12.11.b

The results from the hardness test are not to exceed the following:

- Steel with a specified minimum yield strength  $R_{eH} \leq 420 \text{ N/mm}^2$  ; 350 HV10
- Steel with a specified minimum yield strength  $420 \text{ N/mm}^2 < R_{eH} \leq 690 \text{ N/mm}^2$  ; 420 HV10

#### 4.2 Set of butt weld test specimens for single-side welding processes

4.2.1 Sets of test specimens as specified in para. 4.1, but subject to the differences listed below, shall be taken from butt-weld test pieces for single-side welding processes (e.g. manual or semi-mechanized welding using ceramic backing or submerged-arc welding with flux backing):

- **2 transverse tensile test specimens**, see para. 4.1.1.1.
- **1 round tensile test specimen** taken lengthwise from the weld metal. This is also required when additional welding consumables (e.g. in the form of iron powder and the like) are employed or where the possibility of a metallurgical reaction between the weld metal and the backing material cannot be discounted (see 4.1.1.2)
- **2 transverse bend test specimens** (one FBB and one RBB) and **2 side bend test specimens** (SBB), see 4.1.2.
- **3 notched bar impact test specimens each** additionally from the root zone: from the centre of the weld seam (VWT 0/t-1), the fusion boundary/transition zone (VHT 0/t-1) and heat-affected zone (VHT 2/t-1). See para. 4.1.3.
- **2 macrographic specimens** at least one of which - for manual and semi-mechanized welding processes - must pass through a starting point of welding (see 4.1.4).
- **Hardness tests**, see para. 4.1.5

4.2.2 By analogy with the provisions of para. 4.2.1, the following test specimens shall be taken from butt-welded test pieces prepared by manual or semi-mechanized welding processes already approved by TL for the range of application concerned (base materials, welding positions) for the sole purpose of extending the said approval to single-side welding with backings:

- **2 transverse bend test specimens** with the root in tension (RBB) and **2 side bend test specimens** (SBB). See 4.1.2.

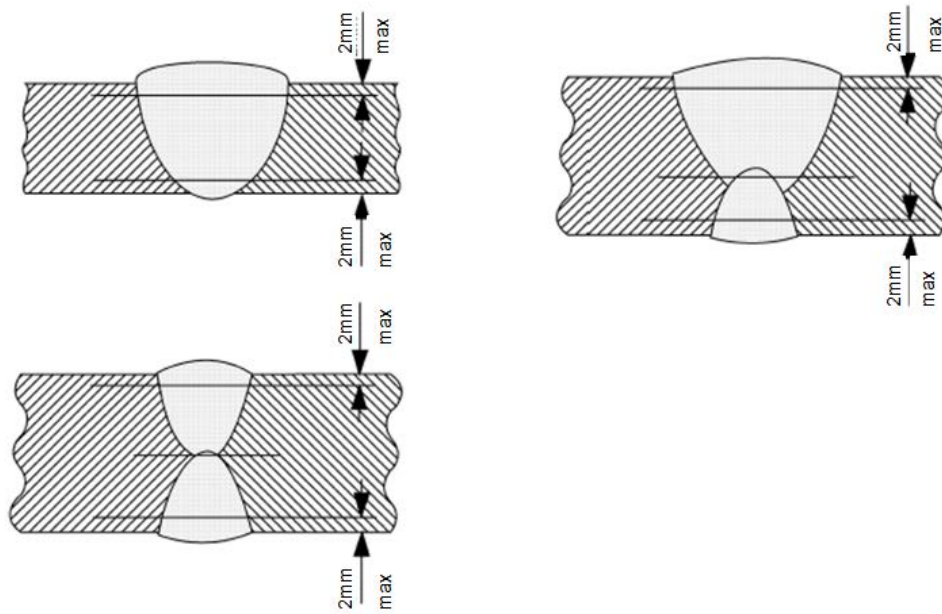

Figure 12.8 Examples of hardness test with rows of indentations in butt welds

Recommended distances *l* between indentations for hardness test in the heat affected zone

Vickers hardness Symbol	Distance between indentations <i>l</i> (mm)
HV 10	1

*Note: The distance of any indentation from the previous indentation is not to be less than the value allowed for the previous indentation by ISO 6507-1.*

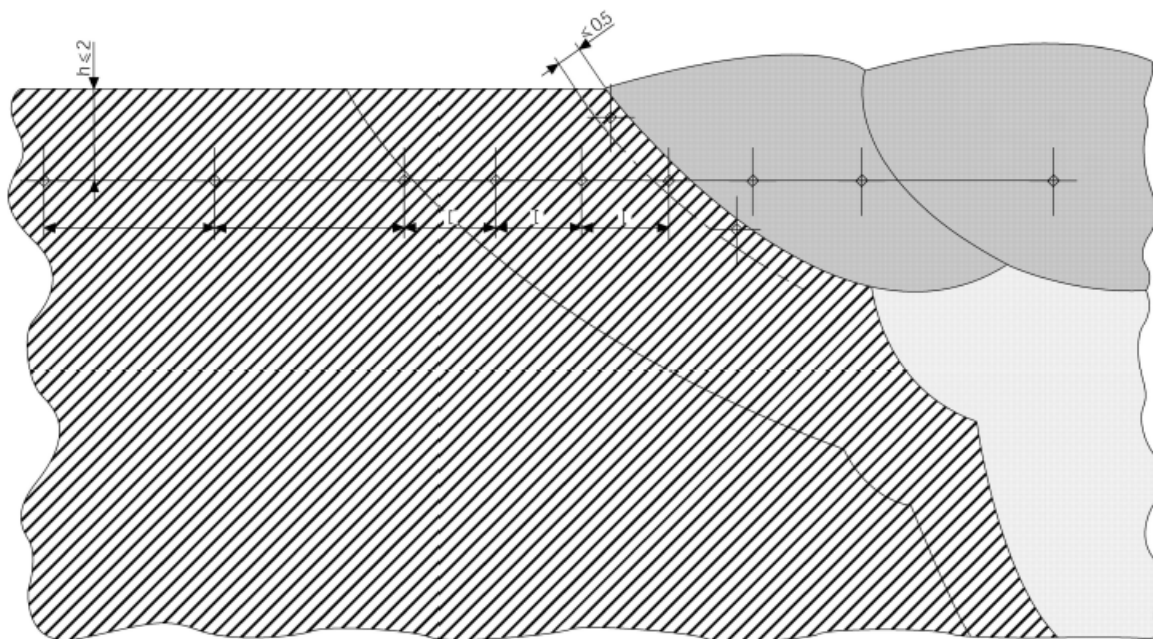

Figure 12.9 Example of hardness indentations in butt welds

**3 notched bar impact test specimens** each only from the root zone: from the centre of the weld seam (VWT 0/t-1), the fusion boundary/transition zone (VHT 0/t-1) and heat affected zone (VHT 2/t-1) where normal-strength, hull structural steel grade E and/or higher-strength hull structural steels are to be welded or where stipulated for other materials (see 4.1.3)

- **2 macrographic specimens**, at least one of which must pass through a starting point of welding in the case of manual and semi-mechanized welding processes. (see 4.1.4).

**hardness tests**, see para. 4.1.5.

#### 4.3 Set of butt weld specimens for vertical welding processes

In accordance with Section 4, B.8.3, one or more sets of test specimens as described in para. 4.1 shall be taken from butt-weld test pieces for vertical welding processes acc. to Figure 12.1 and 12.5 (e.g. electrogas or electroslag welding) as follows:

- **2 transverse tensile test specimens**, see para. 4.1.1.1.
- **1 round tensile test specimen** taken lengthwise from the weld metal. This is also required when additional welding consumables (e.g. in the form of iron powder and the like) are employed (see 4.1.1.2).
- **2 transverse bend test specimens** (one FBB and one RBB) and **2 side bend test specimens** (SBB), see 4.1.2.
- **3 notched bar impact test specimens** each from the centre of the weld seam (VWT 0/2), the edge of the weld seam (VWT a/2), the fusion boundary/transition zone (VHT 0/2) and heat-affected zone (VHT 2/2). The dimension "a" shall be such that the notch lies in the coarsegrained area of the weld metal (normally about 2 - 3 mm). With very large platethicknesses and welding processes liable to cause segregation in the central zone, an

additional 4 notched bar impact test specimens of each type shall be taken from the same areas in the middle of the plate thickness. See 4.1.3.

- **2 macrographic specimens** at least one of which must pass through a starting point of welding (see 4.1.4).
- **Hardness tests**, see para. 4.1.5

#### 4.4 Set of fillet weld test specimens (set of T-jointed test pieces)

Test assemblies are to be examined non-destructively and destructively in accordance with the following:

- Visual testing 100 %
- Surface crack detection 100 % (dye penetrant testing or magnetic particle testing)
- Macro examination two specimen as per 4.4.2
- Hardness test required as per 4.4.3
- Fracture test required as per 4.4.4

##### 4.4.1 Non-destructive testing

Test assemblies are to be examined by visual and by non-destructive testing prior to the cutting of test specimen. In case that any post-weld heat treatment is required or specified non-destructive testing is to be performed after heat treatment. For steels according to UR W16 (Chapter 2 - Material, Section 3, C) with specified minimum yield strength of 420 N/mm<sup>2</sup> and above the non-destructive testing is to be delayed for a minimum of 48 hrs, unless heat treatment has been carried out. NDT procedures are to be agreed with TL.

##### 4.4.2 Macro examination

By analogy with para. 4.1.1, two or more macrographic specimens, as applicable depending on the length of the test piece, shall be taken from the simplified (T-jointed) fillet-welded test pieces in accordance with ISO

15607 to evaluate the penetration conditions, any irregularities in the test piece and the grain structure.

The test specimens are to be prepared and etched on one side to clearly reveal the weld metal, fusion line, root penetration and the heat affected zone.

Macro examination is to include about 10 mm unaffected base metal.

The examination is to reveal a regular weld profile, through fusion between adjacent layers of weld and base metal, sufficient root penetration and the absence of defects such as cracks, lack of fusion etc.

#### 4.4.3 Hardness test

Hardness test is required for steels with specified minimum yield strength of  $R_{eH} \geq 355 \text{ N/mm}^2$ . The Vickers method HV 10 is normally to be used. The indentations are to be made in the weld metal, the heat affected zone and the base metal measuring and recording the hardness values. At least two rows of indentations are to be carried out in accordance with Figure 12.10a, 12.10b, 12.11a and 12.11b. For each row of indentations there is to be a minimum of 3 individual indentations in the weld metal, the heat affected zone (both sides) and the base metal (both sides).

The results from the hardness test are not to exceed the following:

- Steel with a specified minimum yield strength  $R_{eH} \leq 420 \text{ N/mm}^2$ ; 350 HV10
- Steel with a specified minimum yield strength  $420 \text{ N/mm}^2 < R_{eH} \leq 690 \text{ N/mm}^2$ ; 420 HV10

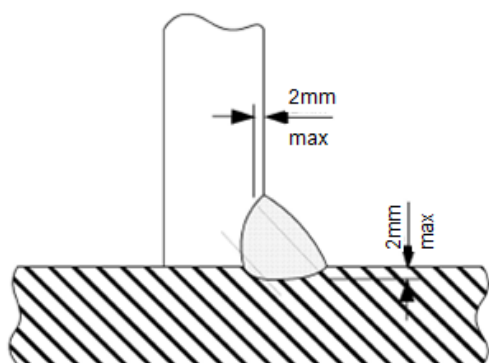

Figure 12.10 a) Example of hardness test with row indentation(R) in fillet welds

#### 4.4.4 Fracture test

The fracture test is to be performed by folding the upright plate onto the through plate.

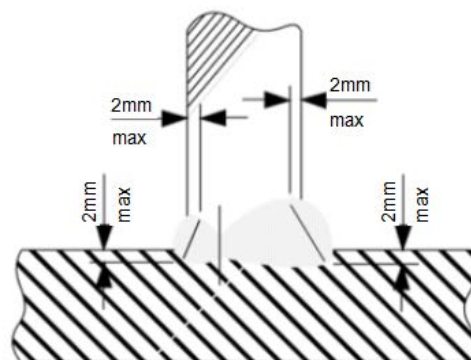

Figure 12.10 b) Example of hardness test with row indentation(R) in T-joint welds

Evaluation is to concentrate on cracks, porosity and pores, inclusions, lack of fusion and incomplete penetration. Imperfections that are detected is to be assessed in accordance with ISO 5817, class B.

#### 4.5 Set of fillet weld specimens (set of double-T jointed (cruciform) test pieces)

4.5.1 As shown in Figures 12.1 and 12.2, one or more sets of test specimens shall be taken from the (cruciform) fillet-welded test pieces depending on the length of the test piece as shown in Figure 12.12. Preparation of specimens, marking, performance of mechanical and technological tests, etc. shall be carried out in accordance with the provisions of Section 11.

4.5.2 A set of (cruciform) fillet weld test specimens as called for in 4.5.1 shall comprise the following specimens. The specimen shapes and dimensions shall conform to the provisions of Section 11.

- **3 cruciform tensile test specimens (Z)** as shown in Figure 12.13 for determining the tensile-shear strength of the weld metal
- **2 macrographic specimens (M)** for evaluating the penetration conditions, any irregularities in the specimens and the grain structure. If necessary, **hardness measurements** (see 4.1.5) shall be performed in accordance with EN ISO 9015-1 and -2 (see 4.1.5).

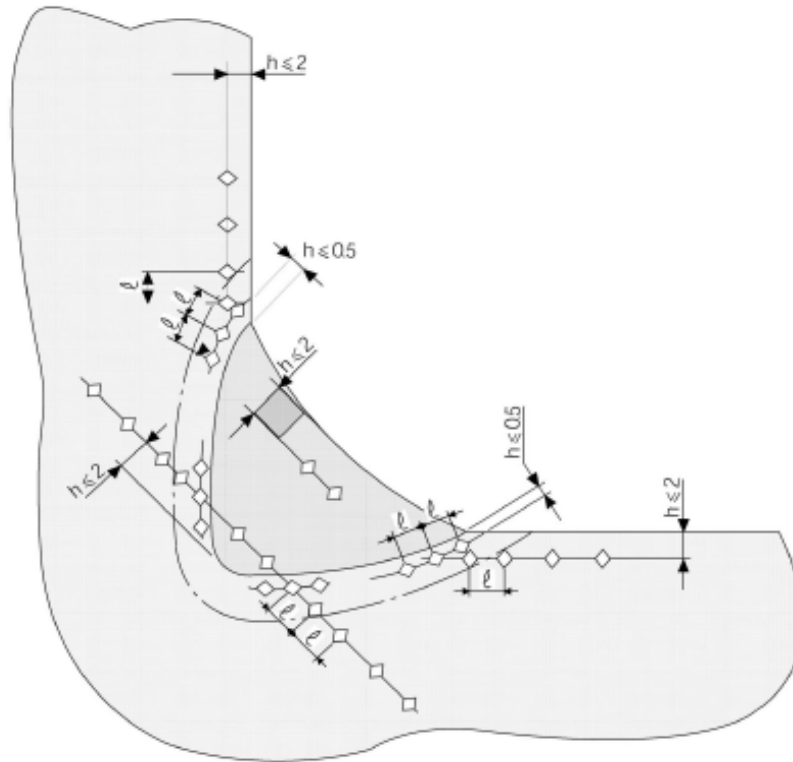

Figure 12.11 a) Example showing the position of the indentations for hardness test in the weld metal, the heat affected zone and the base metal of a fillet weld (dimensions in mm)

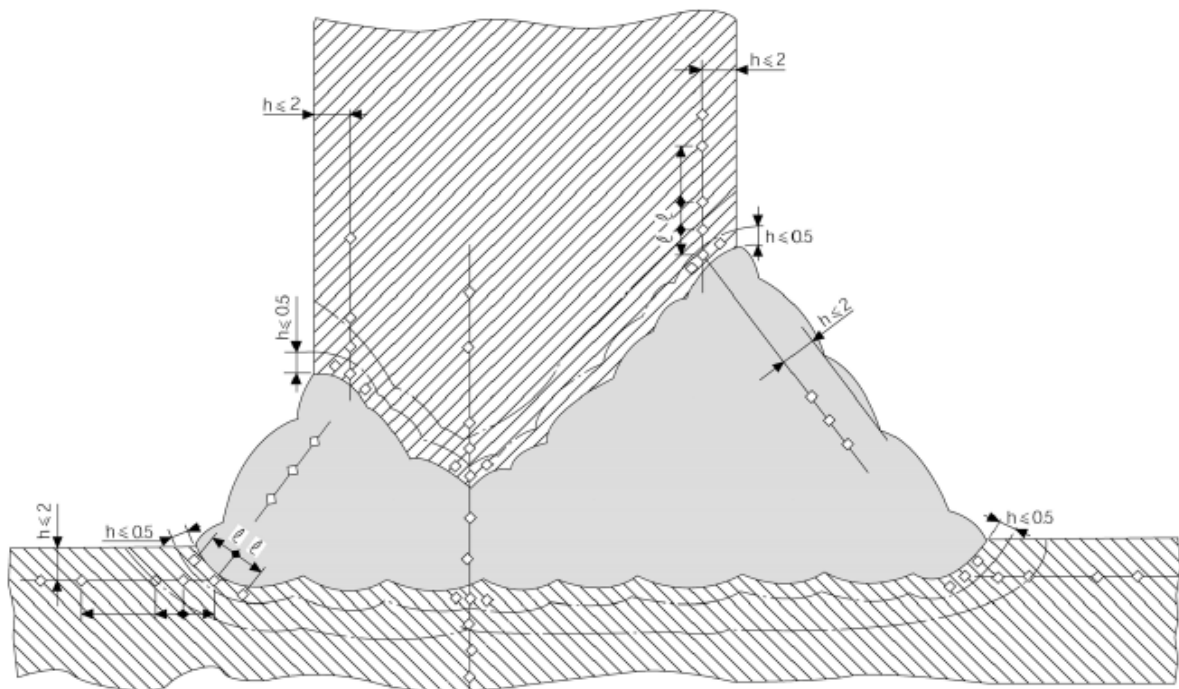

Figure 12.11 b) Example showing the position of the indentations for hardness test on the weld metal, the heat affect zone and the base metal of a T-joint weld (dimensions in mm)

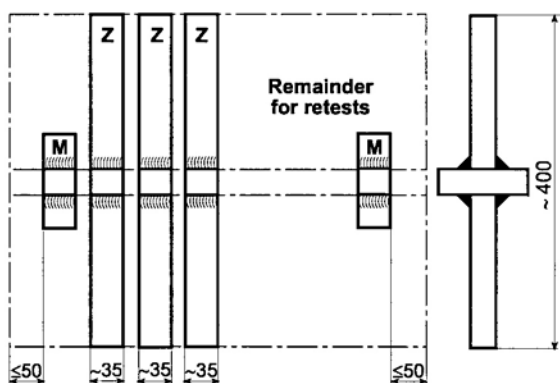
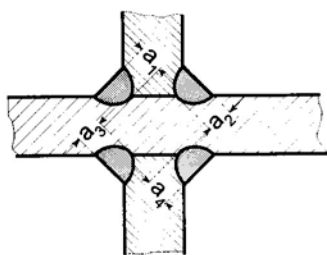

Figure 12.12 Set of double – T (cruciform) test specimens



$$a_1 + a_2 = \text{fracture section } S_{1/2}$$

$$a_3 + a_4 = \text{fracture section } S_{3/4}$$

Tensile shear strength  $Z_S$ :

$$= \frac{\text{Breaking load } F}{S_B \cdot \text{width of specimen}} \left[ \text{N/mm}^2 \right]$$

$$S_B = S_{1/2} \text{ or } S_{3/4} \text{ depending on location fracture}$$

Figure 12.13 Cruciform tensile specimen (weld cross section)

4.5.3 The remainder of the test pieces is to be divided into convenient portions which, after removal of one of the welds, are to be broken open on alternate sides for evaluation of the fracture, see DIN EN ISO 9017.

## 5. Requirements

### 5.1 Hull structural steels

5.1.1 In welding procedure tests and tests on production specimens relating to hull structural steels, butt

weld specimens must meet the minimum requirements shown in Table 12.5. Equivalent structural steels, forged steels and cast steels shall be classified in analogous manner according to their chemical composition and mechanical characteristics.

5.1.2 The minimum impact energy values shown in Table 12.5 apply to the centre of the weld metal, the transition zone/fusion boundary and the heat-affected zone. The values for manual and semi-mechanized welding apply to all positions except the vertical-up position (PF). The values applicable to the vertical position (PF) are those for fully mechanized welding (34 J or 41 J resp.).

*Note:*

*In the fusion boundary/transition zone and/or the heat affected area of "simple" steels, (for example Grade A steels), difficulties may possibly arise in meeting the required values listed in Table 12.5 which have been derived from the requirements relating to welding consumables. In such cases, the values established during the testing of the base material and during appropriate monitoring checks may be used as reference values. The values established on the welded joint should not fall below these reference values.*

5.1.3 In special cases (e.g. where the working temperature of the component is below  $-10^\circ\text{C}$ ), the test temperatures and impact energy values laid down in the material specifications for the testing of the steels concerned may also be stipulated for welding procedure tests in place of the test temperatures and impact energy values shown in Table 12.5. Unless otherwise agreed, these values shall then apply to all welding positions and notch positions.

5.1.4 Where the plate thickness is less than 10 mm, notched bar impact test specimens with a width corresponding to the plate thickness, and wherever possible 7,5 mm. or 5 mm., may be used. In such cases the impact energy values specified in Table 12.5 shall be reduced in accordance with Table 12.6. The notched bar impact test is generally dispensed with for plates less than 5 mm. thick. However, other tests of resistance to brittle fracture may be stipulated.

Table 12.5 Requirements applicable to hull structural steels

Grade	Yield strength (weld metal) [N/mm <sup>2</sup> ]	Tensile strength [N/mm <sup>2</sup> ]	Elongation (weld metal L = 5 d <sub>0</sub> ) [%]	Impact energy (1) (3), (4) (J)			Bending angle (D = 4 t)	Bending elongation gauge length 2 L <sub>S</sub> (2) [%]	
				Temperature [°C]	Manual and semi-mechanised				Full mechanised
					PA,PC,PE	PF, PG			
TL-A(5)	305	400	22	+ 20	47	34	34	180 °	22
TL-B(5), TL-D				0					
TL-E				- 20					
TL-A 32	335	440	22	+ 20	47	34	34	180 °	22
TL-D 32				0					
TL-E 32				- 20					
TL-F 32				- 40					
TL-A 36	375	490	22	+ 20	47	34	34	180 °	22
TL-D 36				0					
TL-E 36				- 20					
TL-F 36				- 40					
TL-A 40	400	510	22	+ 20	47	39	39	180 °	22
TL-D 40				0					
TL-E 40				- 20					
TL-F 40				- 40					

(1) Charpy-V-notch specimen, average value of three specimens.  
(2) The gauge length (L<sub>0</sub>) = weld width (L<sub>S</sub>) + half of the plate thickness on each side adjacent to the weld; see ISO 5173  
(3) In the case of plate thickness > 50 mm, the requirements of the impact energy have to be agreed with TL prior to testing  
(4) The impact requirements are valid for test pieces with weld perpendicular to the rolling direction of the plates.  
(5) For grade A / B, the minimum value of impact energy is 27 J in the fusion line (FL) and in the heat affected zone (HAZ).

**5.1.5** The bending tests are to be performed using a mandrel with a diameter equal to 3 times the thickness ( $t$ ) of the specimen. TL may instead consent to the use of a mandrel with a diameter  $D$  of  $4 \times t$  if this does not impair the reliability of the test results. The required bending angle of  $180^\circ$  under the test conditions specified in ISO 5173 is deemed to have been attained when the specimen has been thrust between the supporting rolls to the minimum distance indicated in Table 6 of this standard. The required bending elongation must be attained before the first incipient crack appears.

Minor pore exposures or the like up to a maximum length of 3 mm. may be tolerated. The fracture surfaces of ruptured test specimens shall be evaluated.

**5.1.6** Measured on cruciform tensile test specimens, the minimum tensile (tensile-shear) strength of the weld section (fracture section in accordance with Figure 12.13) shall meet the requirements stated in Table 12.7.

**Table 12.6**

**Required impact energy values with specimens of reduced width**

Specimen section [mmxmm]	Specified impact energy value to be multiplied by
10 x 7,5	5/6
10 x 5,0	2/3

**Table 12.7**

**Requirements applicable to cruciform tensile specimens**

Grades	Tensile-shear strength [N/mm <sup>2</sup> ]
TL-A - E	350
TL-A32 - F36	430
TL-A40 - F40	450

**5.2 High-strength (quenched and tempered) fine-grained steels**

**5.2.1** For welding procedure tests and tests on production specimens relating to high-strength (quenched and tempered) fine-grained steels, the minimum properties specified in Section 5, F. for the testing of welding consumables and auxiliary materials must be met for butt-weld specimens. Unless otherwise agreed in an individual case, a bending mandrel diameter of 4 times the specimen thickness shall be used for the bending tests. Test temperatures of  $-20^\circ\text{C}$  or below shall be selected for the notched bar impact test.

**5.2.2** Measured on cruciform tensile test specimens (see 3.2.2), the minimum tensile strength (tensile-shear strength) of the weld section (fracture section as shown in Figure 12.13) shall satisfy the requirements relating to the welded joint stipulated in Section 5, F.

**5.3 Austenitic stainless (clad) and austenitic-ferritic (duplex) steels**

**5.3.1** For welding procedure tests and tests on production specimens relating to austenitic stainless (clad) and austenitic-ferritic (duplex) steels, the minimum properties specified in Section 5, I. for the testing of welding consumables and auxiliary materials must be met for butt weld specimens. In the case of joints between different types of steel, the strength values of the base material which has the lower strength shall be used.

**5.3.2** Unless otherwise agreed in an individual case, a bending mandrel diameter of 3 times the specimen thickness may be used for the bending test and a test temperature of  $+20^\circ\text{C}$  for the notched bar impact test performed on austenitic stainless steels. Austenitic-ferritic (duplex) steels shall be tested at a temperature of  $-30^\circ\text{C}$ .

**5.3.3** Measured on cruciform tensile test specimens (see 3.2.2), the minimum tensile strength (tensile-shear strength) of the weld section (fracture section as shown in Figure 12.13) shall satisfy the requirements relating to the welded joint stipulated in Section 5, I. The throat thickness of the fillet welds on clad plates shall be such ( $\leq 0,5 \times$  plate thickness) that the fracture always occurs in the weld seam.

**5.4 Aluminium alloys**



For welding procedure tests and tests on production specimens relating to aluminium alloys, the values specified in Table 12.8 shall be used as guide values for butt weld specimens taken from 5000 and 6000 series alloys as stipulated in TL's Rules for Materials. The tensile strength of the specimens may not on any account be less than the minimum stipulated value for the base material in its "soft" condition.

Different values shall be allowed for where applicable in the design and dimensioning operations. The stipulated tensile strength values apply to test specimens retaining the weld reinforcement. Other aluminium alloys shall be classified in analogous manner and the requirements for these are specified on a case-by-case basis allowing for

the characteristics of the base material and the joint efficiency factors stipulated in EN ISO 15614-2.

### 5.5 Other materials

The requirements applicable to other materials or other test methods will be determined on a case-by-case basis in a manner analogous to that applied to the materials covered earlier, on the basis of their chemical composition, mechanical properties and other characteristics of the base materials and with due regard for the anticipated operating conditions, such as the lowest anticipated service temperature (design temperature).

**Table 12.8 Requirements applicable to aluminium alloys**

Base material		Welded joints (1)			
Alloy No.	Material designation	0,2% proof stress (2) [N/mm <sup>2</sup> ]	Tensile strength [N/mm <sup>2</sup> ]	Bending angle (3) [Degree]	Bending elongation [%]
EN AW-5083	AlMg4,5Mn0,7	125	275	180	18
EN AW-5086	AlMg4	100	240		
EN AW-5383	AlMg4,5Mn0,7mod.	145	290		
EN AW-5754	AlMg3	80	190		
EN AW-5059	AlMg5,5Mn0,8ZnZr	160	330		
EN AW-6005A	AlSiMg(A)	115	170		
EN AW-6061	AlMgSi1Cu	115	170	180	10
EN AW-6082	AlSi1MgMn	125	185		

(1) Using a weld consumable of a quality grade in accordance with the base material according to Section 5, J.  
(2) As far as established (on additional samples which are to be agreed).  
(3) Bending mandrel Ø to be selected depending on the material group and condition according to EN ISO15614-2.

## G. Design, Dimensioning

### *Preliminary remark:*

*The contents of this section are largely identical to the provisions of the Chapter 1- Hull, Section 20.*

### 1. General

1.1 The general design principles described in Section 7 shall be followed.

1.2 Welded joints shall be designed to ensure that the proposed weld type and quality (e.g. complete root fusion in the case of single- and double-bevel butt welds) can be satisfactorily achieved under the given fabricating conditions. Failing this, provision shall be made for welds which are easier to execute and the (possibly lower) load-bearing capacity of these welds shall be allowed for in the dimensional design.

1.3 Severely stressed welded joints, which are therefore normally subject to compulsory inspection, shall be designed such that the most appropriate inspection technique for the detection of defects (radiography, ultrasonic or surface crack inspection) can be applied without restriction so that tests offering reliable results can be carried out.

### 2. Characteristics Related to Materials, Corrosion

2.1 Characteristics related to materials, e.g. the (inferior) strength of rolled products in the thickness direction (see item 7.) or the softening of hardened aluminium alloys when welded, are to be allowed for when designing and dimensioning the components and the welded joints.

2.2 Clad plates where the efficiency of the bond between the support and the superimposed material is proven may generally be treated as solid plates (up to medium plate thicknesses with mostly fillet welds).

2.3 In thermally stressed composite structures made of different materials (e.g. hull structural and stainless steels in the case of tank heating systems), due allowance shall be made for the differences in the

thermal conductivities and especially the rates of thermal expansion of the different steels.

2.4 Where pairs of different materials are exposed to seawater or other electrolytes, e.g. the welded joints between unalloyed and stainless steels in the wear linings of rudder nozzles and in build-up welds on rudderstocks, attention is to be paid to the increased tendency towards corrosion, especially at the weld, due to the differences in electrochemical potential.

2.5 If welded joints of this kind cannot be avoided, they shall whenever possible be located at points where there is less danger of corrosion (e.g. outside tanks) or special corrosion protection shall be provided (e.g. coating or cathodic protection).

### 3. Stress Flow, Transitions

3.1 All welded joints on primary supporting members shall be designed to provide as smooth a stress profile as possible with no major internal or external notches, no discontinuities in rigidity and no obstructions to expansion see Chapter 1 - Hull, Section 3, B.

3.2 This applies in analogous manner to the welding of subordinate components onto primary supporting members whose exposed plate or flange edges should, as far as possible, be kept free from notch effects due to welded attachments. Regarding the inadmissibility of weldments to the upper edge of the sheer strake, see the Chapter 1 - Hull. This applies in analogous manner to weldments to the upper edge of continuous hatchway side coamings.

3.3 Butt joints in long or continuous external structures, such as bilge keels, fenders, slop coamings, crane rails, hatchway cover running rails, compression bars, etc. attached to primary supporting members are therefore to be welded over their entire cross section. Their ends shall be designed in analogous manner to the ends of the doubling plates (see 6.4) with "smooth" transitions into the component underneath.

3.4 Wherever possible, welded joints (especially site joints) in girders and sections shall not be located in areas of high bending stress. Joints at the buckling points of flanges are to be avoided. Full penetration

welds uniting three plates with additional fillet welds applied from the rear side in analogous manner to Fig. 12.27 on buckle stiffeners are generally acceptable.

**3.5** The transition between differing component dimensions shall be smooth and gradual. Where the depth of web of girders or sections differs, the flanges or bulbs are to be bevelled and the web slit and expanded or pressed together to equalize the depth of the members so that the flanges or bulbs, as applicable, may be satisfactorily welded together. The length of the transition should equal at least twice the difference in depth.

**3.6** Where the plate thickness changes at joints running perpendicular to the direction of the main stress, differences in thickness greater than 4 mm, (greater than 3 mm where the thickness of the thinner plate is less 10 mm) must be accommodated by beveling the proud edge in the manner shown in Fig. 12.14 at a ratio of at least 1 : 3 or less according to the notch category see. Chapter 1 - Hull, Section 3, Tablo 3.32. Differences in thickness up to the values stated above may be accommodated within the weld.

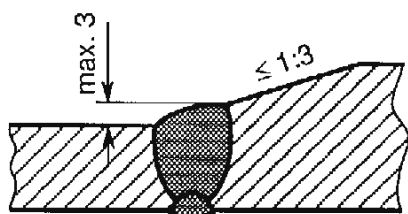
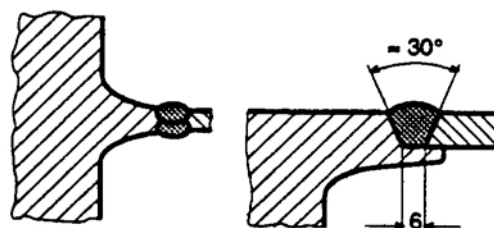

**Fig. 12.14 Accommodation of differences in thickness**

**3.7** For the welding on of plates or other relatively thin-walled elements, steel castings and forgings must be appropriately tapered or provided with integrally cast or forged welding flanges in accordance with Fig. 12.15. Failing this, TL may approve a correspondingly thicker transition piece welded over its entire cross-section to the steel casting or forging in a manner analogous to that for shaft brackets (see Fig.12.33 and 12.25) or to that for the horizontal rudder coupling flanges (see Fig. 12.34).

**3.8** For the connection of shaft brackets to the hub and the shell plating, see 13. and the Chapter 1 - Hull, Section 10, C. For the connection of horizontal coupling flanges to the rudder body, see 14. For the thickened rudderstock collar required with build-up welds and for the connection of the coupling flange, see 9. and 14.

respectively and the Chapter 1 – Hull, Section 18, D. The connection between the rudderstock and the coupling flange must be welded over the entire cross section.



**Fig. 12.15 Welding flange on steel castings and forgings**

#### 4. Local Clustering of Welds, Minimum Spacing, Socket Weldments

**4.1** Local clustering of welds and short distances between welds are to be avoided. Where account has to be taken of higher residual welding stresses due to thicker plates or welds and corresponding rigidity of the components, the preparation should allow for the fact that adjacent butt welds should be separated from each other by a distance of at least

$$50 \text{ mm} + 4 \times \text{plate thickness}$$

Fillet welds should be separated from each other and from butt welds by a distance of at least

$$30 \text{ mm} + 2 \times \text{plate thickness}$$

In this case, the applicable dimensions are edge of fillet weld to edge of fillet weld or edge of fillet weld to centre of butt weld. The width of interchangeable sections (strips) of plates should, however, be at least 300 mm or ten times the plate thickness, whichever is the greater. Other dimensions shall be subject to approval by TL in each individual case as part of the examination of the drawings.

#### Note:

*In special cases, for example where plating bends over its length (e.g. the inner bottom plating in the fore section of the hull or lateral longitudinal bulkheads in the fore and aft sections of the hull), especially in the lower plate thickness*

range (up to approx. 20 mm) it may be advisable, in order to improve buckle stiffening - or where the weld throat thicknesses are not too large (up to about 5 mm) - to reduce the distances stated above or even position the buckle stiffening section or the like directly on the plate weld causing the buckling.

Although the extra fillet welds on the butt joint produce an additional clustering of welds and thus residual welding stresses, this is relatively minor compared with the residual welding stresses which occur in larger plate thicknesses and the correspondingly larger number of passes and may therefore be acceptable as a way of increasing the strength properties of the design. For permitted tolerances, see H.3.

**4.2** Reinforcing plates, welding flanges, drain unions, mountings and similar components socket-welded into plating should be of the following minimum size:

$$D_{\min} = 170 + 3 \cdot (t-10) \geq 170 \text{ [mm]}$$

where

D = Diameter of round or length of side of angular socket weldments in [mm]

t = Plating thickness in [mm]

With angular socket weldments, the corner radii should be at least 50 mm or the "longitudinal seams" should be extended beyond the "transverse joints". Socket weldments shall be welded to the surrounding plating over the entire cross-section. For the provisions relating to the increase in stresses due to possible differences in thickness, see Chapter 1 Hull Section 3 D.5.1.3.

## 5. Welding Apertures

**5.1** Welding apertures for the (later) execution of butt or fillet welds following the positioning of transverse members should be rounded (minimum radius 25 mm or twice the plate thickness, whichever is the greater) and (especially where the loading is mainly dynamic) should be shaped to provide a gentle transition to the adjoining surface and adequately notch-free welding should be carried out around the end faces as shown in Fig. 12.16

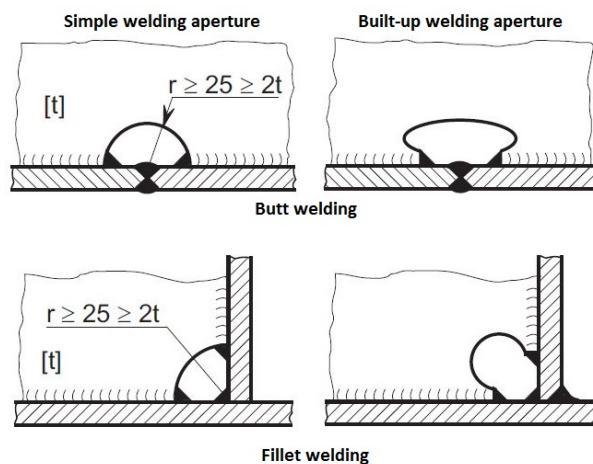

**Fig. 12.16** Welding apertures

**5.2** Where the welds are completed prior to the positioning of transverse members, no welding apertures are needed. Any weld reinforcements present are to be machined off prior to positioning the transverse member, or the members to be positioned are to be notched accordingly.

## 6. Local Reinforcements, Plate Doublings

**6.1** Where platings (including girder plates and tube walls) are subjected locally to increased stresses, thicker plates should be used wherever possible in preference to plate doublings. Bearing bushes, hubs, etc. shall invariably take the form of thicker sections welded into the plating (see 4.2).

**6.2** Where doublings cannot be avoided, the thickness of the doubling plate should not exceed twice the plating thickness. Doubling plates whose width is greater than approximately 30 times their thickness shall be plug-welded to the underlying plating in accordance with 10.5 at intervals not exceeding 30 times the thickness of the doubling plate

**6.3** Along their (longitudinal) edges, doubling plates shall be continuously fillet welded with a throat thickness "a" of 0,3 x the doubling plate thickness. At the ends of doubling plates, the throat thickness "a" at the end faces shall equal 0,5 x the doubling plate thickness t, but shall not exceed the plating thickness (see Fig. 12.17).

**6.4** The weld joining the end faces to the plating should make a smooth transition with the latter at an angle of 45° or less.

Where proof of fatigue strength is demanded, see Chapter 1 - Hull, Section 3 the ends of the doubling plates must be designed so that they comply with the detail category selected.

**6.5** Doubling plates are not acceptable in tanks for flammable liquids, gases or chemicals.

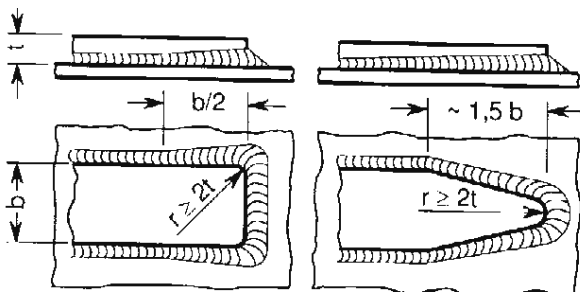

**Fig. 12.17** Weld at the ends of doubling plates

## 7. Transverse Members, Stress in the Thickness Direction

**7.1** Where, in the case of members lying transverse to each other, plates or other rolled products are stressed in the thickness direction by residual stresses due to the welding and/or by applied loads, suitable measures shall be taken in the design and fabrication of the structures to prevent lamellar tearing (stratified fractures) due to the anisotropy of the rolled products.

**7.2** Such measures include the use of suitable weld shapes with a minimum weld volume and an appropriate welding sequence designed to reduce transverse shrinkage. Other measures are the distribution of the stresses over a larger area of the plate surface by using a build-up weld or the "joining together of several layers" of members stressed in the thickness direction, as exemplified by the deck stringer/sheer strake joint shown in Fig. 12.26.

**7.3** Where there are very severe stresses in the thickness direction (due, for example, to the aggregate effect of the shrinkage stresses of bulky single- or double-bevel welds plus high applied loads), plates with guaranteed through thickness strength properties are to be used (higher degree of purity and guaranteed minimum reductions in area of  $\geq 20\%$  of tensile test specimens taken in the thickness direction).

**7.4** Sandwiched flat bar steel positioned transversely to the direction of force (e.g. for use as backings for plug welding or to accommodate excessive air gaps) are not permitted where components intersect.

## 8. Welding of Cold-Formed Sections, Bending Radii

**8.1** In structural steels with a tendency towards strain ageing, welding of the cold-formed sections with more than 5 % permanent elongation and the adjacent areas with 5 x plate thickness should be avoided wherever possible.

Elongation  $\epsilon$  in the outer tensile stressed zone (in %):

$$\epsilon = \frac{100}{1 + 2 \cdot r/t}$$

$r$  = Inner bending radius in [mm]

$t$  = Plate thickness in [mm]

In case of doubt **TL** may demand proof (e.g. in the form of notched bar impact tests) that cold forming and subsequent welding have not caused any unacceptable reduction in toughness characteristics.

**8.2** Welding of the cold-formed sections and adjacent areas of hull structural steels and comparable structural steels (e.g. quality groups S...J... or S...K... conforming to EN 10025-1) may be performed, provided that the minimum bending radii are not less than those specified in Table 12.9

**Table 12.9** Minimum bending radii for welding of cold-formed sections

Plate thickness $t$	Minimum inner bending radius $r$
4 mm. or less	1xt
8 mm. or less	1,5xt
12 mm. or less	2xt
24 mm. or less	3xt
Over 24 mm.	5xt

**Note:**

*The bending capacity of the material may necessitate a larger bending radius.*

**8.3** For other steels and, where applicable, other materials, the necessary minimum bending radius shall, in case of doubt, be established by test. Proof of adequate toughness after welding may be stipulated for steels with minimum yield strengths of more than 355 N/mm<sup>2</sup> and plate thicknesses of 30 mm. and above which have undergone cold forming resulting in 2 % or more permanent elongation.

## 9. Build-up Welds on Rudderstocks and Pintles

**9.1** Wear-resistant and/or corrosion-resistant build-up welds on the bearing surfaces of rudder-stocks, pintles, etc. shall be applied to a thickened collar exceeding by at least 20 mm the diameter of the adjoining part of the shaft.

**9.2** Where a thickened collar is impossible for design reasons, the build-up weld may be applied to the smooth shaft provided that relief-turning in accordance with 9.3 is possible (leaving an adequate residual diameter).

**9.3** After welding, the transition areas between the welded and non-welded portions of the shaft shall be relief-turned with large radii, as shown in Fig. 12.18, to remove any base material whose structure close to the concave groove has been altered by the welding operation and in order to effect the physical separation of geometrical and "metallurgical" notches.

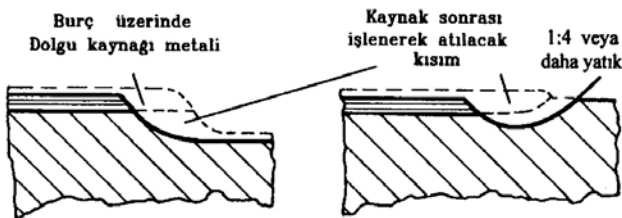

**Fig. 12.18 Build-up welds applied to rudder-stocks and pintles**

**9.4** If, during a repair, a build-up weld is exceptionally to be applied to the smooth shaft without relief turning with the special permission of TL, this weld shall be made in analogous manner to 9.3 (at an adequate distance beyond the zone of maximum bending stress)

as shown in Fig. 12.19 in such a way that at least two passes of weld metal remain in the smooth part of the shaft after machining. The transition between the build-up weld and the shaft must be machined cleanly and free of notches.

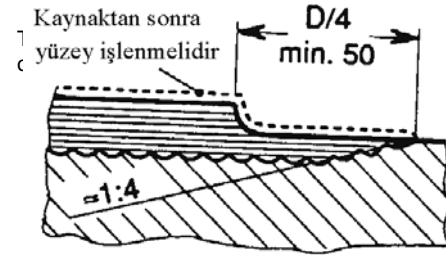

**Fig. 12.19 Repair made by build-up welding**

**9.5** Build-up welding may only be carried out using a fully mechanized process approved by TL (e.g. submerged-arc welding) in the circumferential direction on a rotating fixture.

## 10. Weld Shapes and Dimensions

### 10.1 Butt joints

**10.1.1** Depending on the plate thickness, the welding process and the welding position, butt joints shall take the form of square, V or double-V welds (double V butt joints) conforming to the standards (e.g. ISO 2553, EN 29629, EN ISO 9692-2, DIN 8552 or EN ISO 9692-4). The weld shapes shall be illustrated in the drawings or in other production documents, together with the standard symbols.

**10.1.2** Where weld shapes are proposed other than those specified in the standards, these are to be specially described in the drawings. Weld shapes for special welding processes (e.g. submerged-arc, single-side welding, electrogas or electroslog welding) must have been tested and approved in the context of a welding procedure test.

**10.1.3** As a matter of principle, the rear sides of butt joints shall be grooved and welded with at least one backing run (capping pass). Exceptions to this rule, as in the case of submerged-arc welding or the welding processes mentioned in 10.1.1, require testing and approval in the context of a welding procedure test.

**10.1.4** Where the aforementioned conditions cannot be met (e.g. where the welds are accessible from one side only), the joints shall be executed as lesser bevelled welds with an open root and an attached or an integrally machined or cast permanent weld pool support (backing), as shown in Fig. 12.20

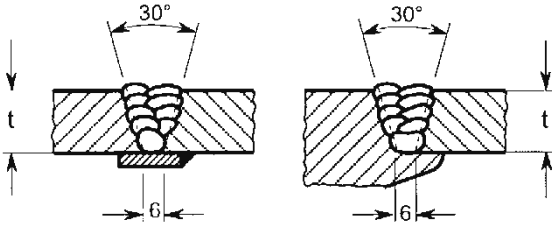

**Fig. 12.20** Single-side welds with permanent weld pool supports (backings)

**10.1.5** The effective weld thickness is deemed to be the plate thickness or, where the plate thicknesses differ, the lesser plate thickness. Where proof of fatigue strength is required (see 15.3), the detail category depends on the workmanship (geometry and quality) of the weld.

**10.1.6** The weld shapes illustrated in Fig. 12.21 shall be used for clad plates. These weld shapes shall be used in analogous manner for corner joints and for joining clad plates to (unalloyed and low-alloy) hull structural steels.

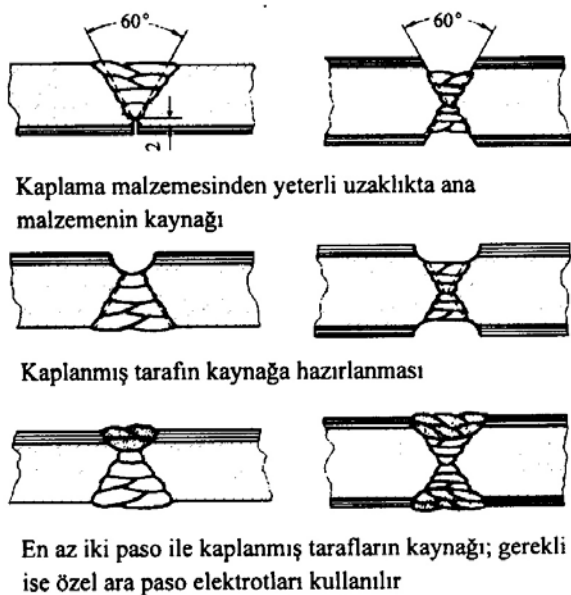

**Fig. 12.21** Weld shapes for welding of clad plates

## 10.2 Corner, T and double-T (cruciform) joints

**10.2.1** Corner, T and double-T (cruciform) joints with

full root penetration connection of the abutting plates shall be executed as single- or double-bevel welds with a minimum root face and adequate air gap, as shown in Fig. 12.22, and with grooving of the root and capping from the opposite side.

The effective weld thickness is deemed to be the thickness of the abutting plate. Where proof of fatigue strength is required (see 15.3), the detail category depends on the workmanship (geometry and quality) of the weld.

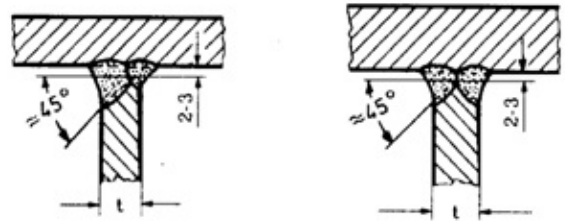

**Fig. 12.22** Single- and double-bevel welds with full root penetration

**10.2.2** Corner, T and double-T (cruciform) joints with a defined incomplete root penetration "f", as shown in Fig. 12.23 shall be executed as single- or double-bevel welds, as described in 10.2.1, with capping from the rear side but without grooving of the root.

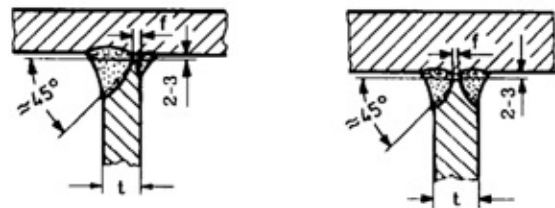
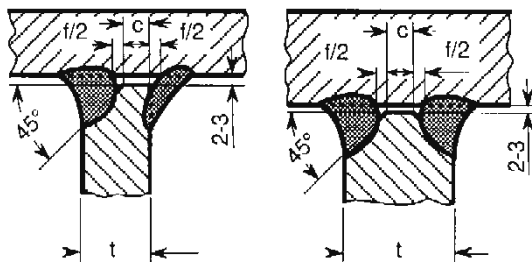

**Fig. 12.23** Single- and double-bevel welds with defined incomplete root penetration

The effective weld thickness may be deemed to be the thickness  $t$  ( $- f$ ) of the abutting plate, the assumed incomplete root penetration  $f = 0,2t$ , max. 3 mm, being compensated for by means of additional fillet welds of at least equal size applied to each side. As a practical dimension, a leg length of  $z = h/3$  at the root of the weld may be prescribed where  $h$  is the depth of the weld as shown in the Figure 12.23. If proof of fatigue strength is required (see 15.3) and depending on the plate thickness to weld thickness ratio, these welds are to be classified according to type no. D1 detail class in accordance with the Chapter 1 - Hull, Section 3, Table 3.32.

**10.2.3** Corner, T and double-T (cruciform) joints with an unwelded root face "c" and an incomplete root penetration "f" which is also to be allowed for shall be executed in accordance with Fig. 12.24.

The effective weld thickness is deemed to be the thickness of the abutting plate  $t - (f+c)$ , where  $f$  is to be assigned a value of  $0,2 t$  subject to a maximum of 3 mm. Where proof of fatigue strength is required (see 15.3), and depending on the plate thickness to weld thickness ratio, these welds are to be classified according to type no. D2 or D3 detail classes in accordance with the Chapter 1 - Hull, Section 3, Table 3.32.



**Fig. 12.24 Single- and double-bevel welds with unwelded root face and defined incomplete root penetration**

**10.2.4** Corner, T and double-T (cruciform) joints which are accessible from one side only may be executed in accordance with Fig. 12.25 in a manner analogous to the butt joints referred to in 10.1.4 using a weld pool support (backing) or as single-side single-bevel welds laid down in a manner similar to that prescribed in 10.2.2.

The effective weld thickness shall be determined by analogy with 10.1.5 or 10.2.2, as appropriate. Wherever possible, these joints should not be used where proof of fatigue strength is required (see 15.3).

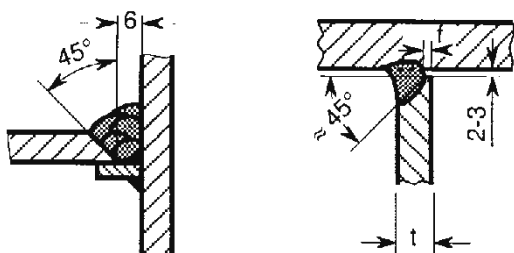

**Fig. 12.25 Single-side welded T-joints**

**10.2.5** Where corner joints are flush, i.e. with neither of the plates standing proud, the weld shapes shall be as shown in Fig. 12.26 with bevelling of the perpendicularly juxtaposed plates to avoid the danger of lamellar tearing see 7. A similar procedure is to be followed in the case of fitted T-joints (uniting three plates) where the perpendicular plate illustrated is to be socketed (between two horizontal plates).

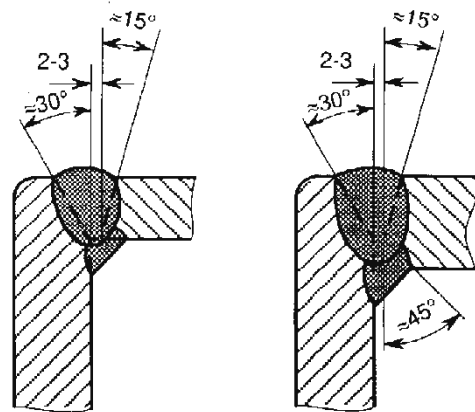

**Fig. 12.26 Flush fitted corner joints**

**10.2.6** Where, in the case of T-joints (uniting three plates), the direction of the main stress lies in the plane of the horizontal plates (e.g. the plating) shown in Fig. 12.27 and the connection of the perpendicular (web) plates is of secondary importance, welds uniting three plates may be made in accordance with Fig. 12.27 (with the exception of those subjected mainly to dynamic loads).

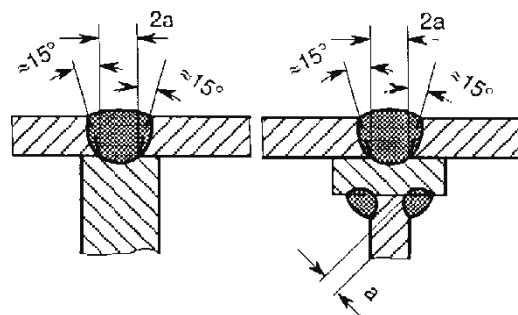

**Fig. 12.27 Welding together three plates**

The effective thickness of the weld uniting the horizontal plates shall be determined by analogy with 10.1.5. The requisite "a" dimension is determined by the joint uniting the vertical (web) plates and shall, where necessary, be determined in accordance with the Chapter 1 - Hull, Section 20 or by calculation as for fillet welds.



### 10.3 Fillet weld joints

**10.3.1** Fillet welds shall normally be made on both sides, and exceptions to this rule (as in the case of closed box girders and predominant shear stresses parallel to the weld) are subject to approval in each individual case. The throat thickness "a" of the weld (the height of the inscribed isosceles triangle) shall be determined in accordance with the Chapter 1 - Hull, Section 20, Table 20.3 or by calculation in accordance with 15. The leg length "z" of a fillet weld is to be not less than 1,4 x the throat thickness "a". For fillet welds at doubling plates see 6.3; for the welding of deck stringers to shear strakes, see the Chapter 1 - Hull, Section 20.

**10.3.2** The relative fillet weld throat thicknesses specified in the above-mentioned Table 20.3 relate to normal- and higher-strength hull structural steels and comparable structural steels. They may also be applied to high-strength structural steels and non-ferrous metals provided that the tensile-shear strength of the weld metal used is at least equal to the tensile strength of the base material. Failing this, the "a" dimension shall be increased accordingly and the necessary increment shall be established during the welding procedure test. Alternatively, proof by calculation taking account of the properties of the weld metal may be presented.

**Note:**

*In the case of higher-strength aluminium alloys (e.g. AlMg 4,5 Mn), such an increment may be necessary for cruciform joints subject to tensile stresses, as experience shows that in the welding procedure tests the tensile-shear strength of fillet welds (made with matching filler metal) often fails to attain the tensile strength of the base material.*

**10.3.3** The throat thickness of fillet welds shall not exceed 0,7 times the lesser thickness of the parts to be welded (the web thickness, for instance). The minimum weld thickness is defined by the expression :

$$a_{\min} = \sqrt{\frac{t_1 + t_2}{3}} \text{ [mm]}$$

where

$t_1$  : Lesser (e.g. the web) plate thickness in [mm]

$t_2$  : Greater (e.g. the flange) plate thickness in [mm]

See Section 7.

**10.3.4** It is desirable that the fillet weld section should be flat faced with smooth transitions to the base material. Where proof of fatigue strength is required (see 15.3), machining of the weld (grinding to remove notches) may be required depending on the detail category. The weld should penetrate at least close to the theoretical root point (see Fig. 12.28).

**10.3.5** Where mechanized welding processes are used which ensure deeper penetration extending well beyond the theoretical root point and where such penetration is uniformly and dependably maintained under production conditions, approval may be given for this deeper penetration to be allowed for in determining the throat thickness. The effective dimension

$$a_{\text{deep}} = a + \frac{2 \min e}{3} \text{ [mm]}$$

shall be ascertained in accordance with Fig. 12.28 and by applying the term "min e", which is to be established for each welding process by a welding procedure test. The throat thickness shall not be less than the minimum throat thickness related to the theoretical root point.

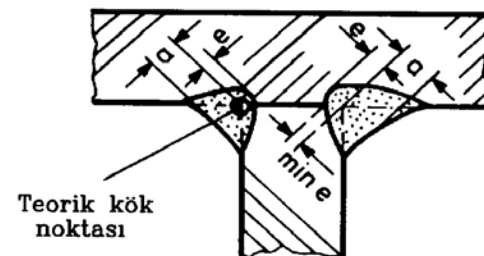

**Fig. 12.28 Fillet welds with increased penetration**

**Note:**

*In the case of welding processes where there is a particularly deep, narrow penetration, as occurs for example in laser welding without welding consumable in which no significant fillet weld is produced but the entire welded joint is virtually shifted "inwards", the above requirement for a specific minimum fillet weld thickness may be difficult or impossible*

to meet. In such cases the extent of the effect of the weld shape (if any) on the characteristics of the welded joint (e.g. resistance to cracking, strength) shall be assessed and/or verified in the welding procedure test, taking into consideration any fatigue strength requirements which may be stipulated. The details of this shall be agreed with TL on a case-by-case basis.

**10.3.6** When welding on top of shop primers which are particularly liable to cause porosity, an increase of the "a" dimension by up to 1 mm may be stipulated depending on the welding process used. This is especially applicable where minimum fillet weld throat thicknesses are employed. The size of the increase shall be decided on a case-by-case basis allowing for the nature and the severity of the loading according to the results of the examination of the shop primer in accordance with Section 6 or of the welding procedure test or production tests, as applicable. This applies in analogous manner to welding processes where provision has to be made for inadequate root penetration.

**10.3.7** Strengthened fillet welds continuous on both sides are to be used in areas subjected to severe dynamic loads (e.g. for joining the longitudinal and transverse girders of the engine base to top plates close to foundation bolts, see the Section 20, Table 20.3 and Chapter 1 - Hull, Section 8, B. Unless single- or double-bevel welds are stipulated in these locations. In these areas the fillet weld throat thickness "a" shall equal 0,7 times the lesser thickness of the parts to be welded.

**10.3.8** Intermittent fillet welds may be located opposite each other (chain intermittent welds, possibly with scallops) or may be offset (staggered welding), in accordance with the Chapter 1 - Hull, Section 20, Table 20.3 (see Fig. 12.29). The use of different scallop shapes and dimensions may be agreed on for very small sections.

In water and cargo tanks, in the bottoms of fuel tanks and of rooms where pools of condensation or spray water may collect, and in hollow components (e.g. rudders) threatened by corrosion, only continuous fillet welds or intermittent welds with scallops shall be used. The same applies in analogous manner to areas, components or compartments which are exposed to extreme weather conditions or to a corrosive cargo.

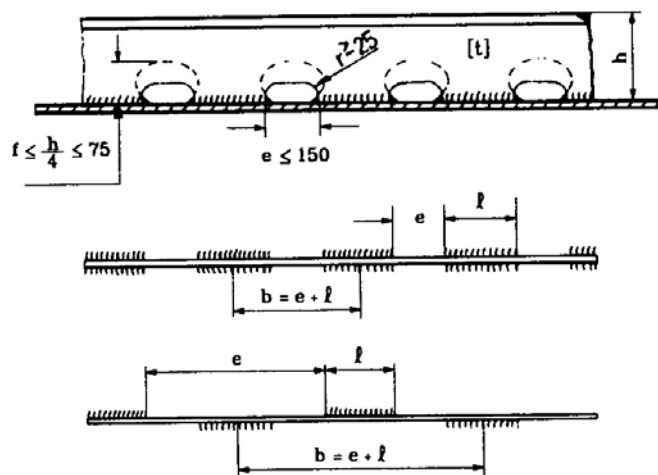

**Fig. 12.29 Scallop, chain and staggered welds**

There shall be no scallops in areas where the plating is subjected to severe stresses (e.g. in the bottom section of the fore ship) and continuous welds are to be preferred where the loading is chiefly dynamic.

**10.3.9** The throat thickness  $a_u$  of intermittent fillet welds is to be determined according to the selected pitch ratio  $b/l$  by applying the following formula:

$$a_u = 1,1 \cdot a \cdot b/l \quad [\text{mm}]$$

where

- a = Necessary fillet weld throat thickness for a continuous weld conforming to the Chapter 1 - Hull, Section 20, Table 20.3 or determined by calculation in [mm],
- b = Pitch =  $e + l$  in [mm],
- e = Interval between the welds in [mm],
- $l$  = Length of fillet weld in [mm].

The pitch ratio  $b/l$  may not be greater than 5. The maximum unwelded length ( $b - l$  with scallop and chain welds or  $b/2 - l$  with staggered welds) shall not exceed 25 times the lesser thickness of the parts to be welded. However, the length of the scallops shall not exceed 150 mm.

#### 10.4 Lapped joints

**10.4.1** Lapped joints running transversely to the main direction of load should be avoided wherever possible

and may not be used for heavily loaded components. Lapped welds may be accepted for components subject to low loads (excluding, however, tanks for chemicals, combustible liquids or gases) provided that wherever possible, they are orientated parallel to the direction of the main stress.

**10.4.2** The width of the lap shall be  $1,5 t + 15$  mm ( $t$  = thickness of the thinner plate). Except where another value is determined by calculation, the fillet weld throat thickness "a" shall equal 0,4 times the thickness of the thinner plate, subject to the requirement that it shall not be less than the minimum throat thickness prescribed in 10.3.3. The fillet weld must be continuous on both sides and must meet at the ends.

### 10.5 Plug welding

In the case of plug welding, the plugs should, wherever possible, take the form of elongated holes lying in the direction of the main stress. The distance between the holes and the length of the holes may be determined by analogy with the pitch "b" and the fillet weld length "l" in the intermittent welds covered by 10.3.8. The fillet weld throat thickness "a<sub>w</sub>" may be established in accordance with 10.3.9.

The width of the holes shall be equal to at least twice the thickness of the plate and shall not be less than 15 mm. The ends of the holes shall be semicircular.

Plates or sections placed underneath should at least equal the perforated plate in thickness and should project on both sides to a distance of  $1,5 x$  the plate thickness subject to a maximum of 20 mm. Wherever possible, only the necessary fillet welds shall be made, while the remaining void is packed with a suitable filler.

Lug-joint welding is not permitted.

## 11. Welding at the Ends of Girders and Stiffeners

**11.1** As shown in Fig. 12.30, the web at the end of intermittently welded girders or stiffeners is to be continuously welded to the plating or the flange plate, as

applicable, over a distance at least equal to the depth "h" of the girder or stiffener subject to a maximum of 300 mm. Regarding the strengthening of the welds at the ends, normally extending over 0,15 of the span, see Chapter 1 - Hull, Section 20, Table 20.3.

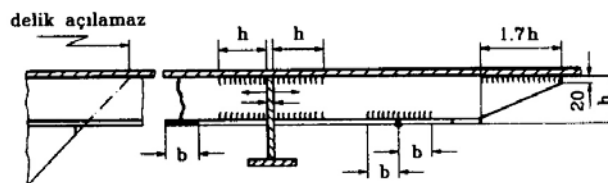

**Fig. 12.30** Welds at the ends of girders and stiffeners

**11.2** The areas of bracket plates should be continuously welded over a distance at least equal to the length of the bracket plate. Scallops shall be located only beyond a line imagined as an extension of the free edge of the bracket plate.

**11.3** Wherever possible, the free ends of stiffeners shall abut against the transverse plating or the webs of sections and girders so as to avoid stress concentrations in the plating. Failing this, the ends of the stiffeners shall be cut off obliquely and shall be continuously welded in accordance with Fig. 12.30 over a distance of at least  $1,7 h$ , subject to a maximum of 300 mm. Different dimensions may be agreed for very small sections.

**11.4** Where butt joints occur in flange plates, the flange shall be continuously welded to the web on both sides of the joint over a distance "b" at least equal to the width of the flange.

**11.5** In the case of girders lying transversely to each other, e.g. as shown in Fig. 12.30, and section passages, a continuous weld shall also be made, by analogy with 11.1, on the girder depicted in section in the figure on both sides of the point where the girders cross.

## 12. Joints Between Section Ends and Plates

**12.1** Welded joints uniting section ends and plates (e.g. at lower ends of frames) may be made in the same plane or lapped. Where no design calculations have

been carried out or stipulated for the welded connections, the joints may be made analogously to those shown in Fig. 12.31.

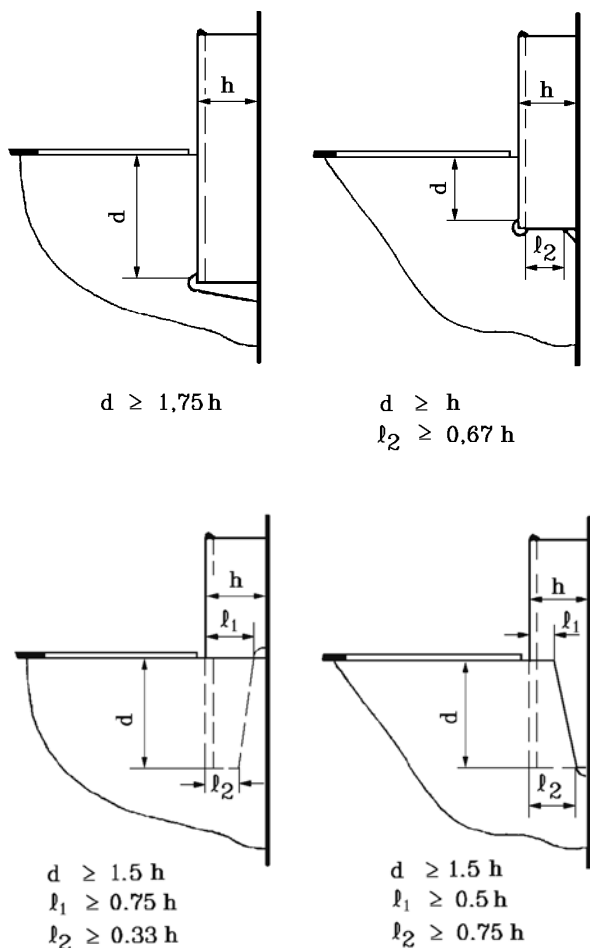

Fig. 12.31 Joints uniting section ends and plates

**12.2** Where the joint lies in the plane of the plate, it may conveniently take the form of a single-bevel butt weld with fillet. Where the joint between the plate and the section end overlaps, the fillet weld must be continuous on both sides and must meet at the ends. The necessary "a" dimension is to be calculated in accordance with the Chapter 1 - Hull, Section 20, C.2.6. The fillet weld throat thickness shall not be less than the minimum specified in 10.3.3.

### 13. Welded Shaft Bracket Joints

**13.1** Unless cast in one piece or provided with integrally cast welding flanges analogous to those prescribed in 3.7 (see Fig. 12.32), strut barrel and struts are to be joined to each other and to the shell plating in the manner shown in Fig. 12.33.

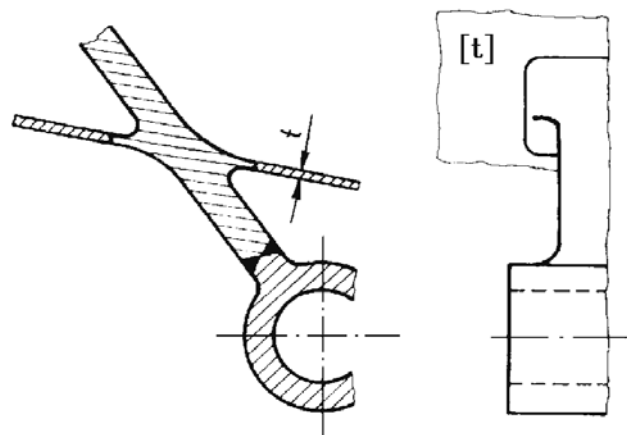
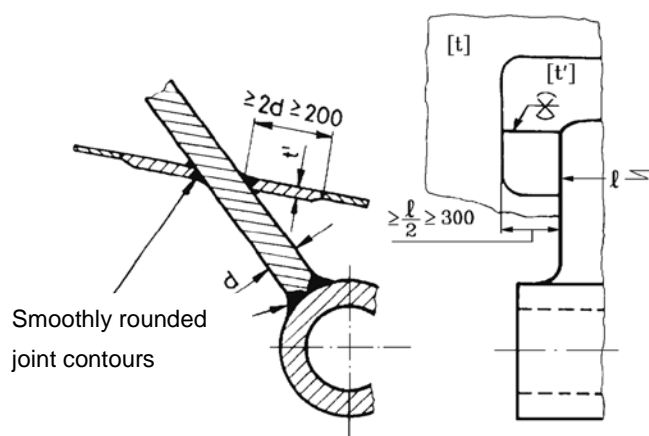

Fig. 12.32 Shaft bracket with integrally cast welding flanges



$t$  = Plating thickness in accordance with the Chapter 1 - Hull in [mm]

$$t' = \frac{2/3 d_{\max}}{3} + 5 \text{ [mm]} \quad \text{for } d < 50 \text{ mm}$$

$$t' = 3 \cdot \sqrt{d} \text{ [mm]} \quad \text{for } d \geq 50 \text{ mm}$$

Fig. 12.33 Shaft bracket without integrally cast welding flanges

**13.2** In the case of single-strut shaft brackets, no welding may be performed on the arm at or close to the position of constraint. Such components must be provided with integrally forged or cast welding flanges. Alternatively, a design in accordance with Fig. 12.34 may be used, subject to the consent of TL in each individual case. If so, it is essential to keep the concave groove free from welds or other notches.

**14. Rudder Coupling Flanges**

**14.1** Unless forged or cast steel flanges with integrally forged or cast welding flanges in conformity with 3.7 are used, horizontal rudder coupling flanges are to be joined to the rudder body by plates of graduated thickness and full penetration single- or double-bevel welds as prescribed in 10.2.1 (see Fig. 12.35). See also Chapter 1 - Hull, Section 18, D.1.

**14.2** Allowance shall be made for the reduced strength of the coupling flange in the thickness direction (see 2.1 and 7.). In case of doubt, proof by calculation of the adequacy of the welded connection shall be produced.

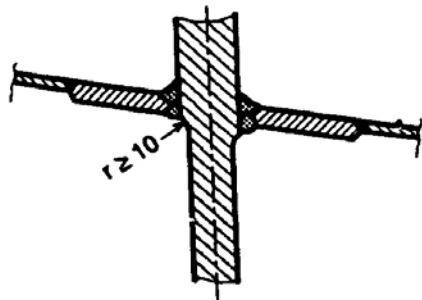

**Fig. 12.34 Single-strut shaft bracket**

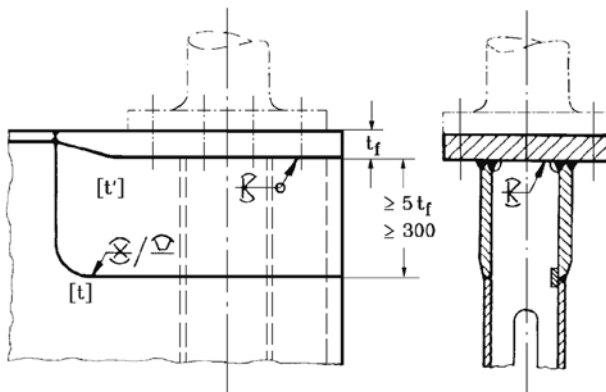

**Fig. 12.35 Horizontal rudder coupling flanges**

$t$  = Plating thickness in accordance with the Chapter 1 - Hull, Section 18, D.1 in [mm].

$t_f$  = Actual flange thickness

$$t' = \frac{t_f}{3} + 5 \quad [\text{mm}] \quad t_f < 50 \text{ mm.}$$

$$t' = 3 \cdot \sqrt{t_f} \quad [\text{mm}] \quad t_f \geq 50 \text{ mm.}$$

**14.3** The use of horizontal couplings for spade rudders is permitted only if the specified thickness of the coupling flanges is less than 50 mm. If this is not the case, taper couplings shall be used. Taper couplings are the only type permitted for high-performance spade rudders. See also Chapter 1 - Hull, Section 18.

**14.4** The welded joint between the rudder shaft (with thickened collar, see 3.8) and the flange shall be made in accordance with Fig. 12.36 in such a way that the concave groove at the transition to the thickened collar remains absolutely free of welds.

Where necessary, the transition shall be machined to remove notches. For larger flange thicknesses, it is advisable to carry out a single-U weld preparation instead of a double-bevel butt weld

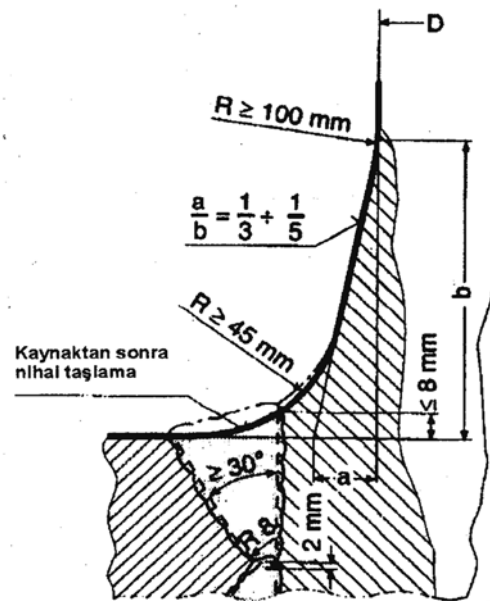

**Fig. 12.36 Welded joint between rudder shaft and coupling flange**

**15. Design Calculations Applied to Welded Joints**

**15.1 General**

Any calculation relating to welded joints which is stipulated in the Rules or prescribed as an alternative to the rules governing dimensions shall be performed in accordance with the Chapter 1 - Hull, Section 20. Calculations conforming to other rules, standards or codes (e.g. DIN 15018, EN 1993-1994 (DIN 18800) or

DIN EN V 1993 (Eurocode 3)) are subject to the prior consent of **TL**.

### 15.2 General stress analysis

Proof by calculation of adequate dimensioning with mainly static loading (a general stress analysis) is required where the thickness of butt welds, T-joints or double-T (cruciform) joints cannot be regarded as equal to the plate thickness or the throat thicknesses of fillet welds do not conform to the tables (see Chapter 1 - Hull, Section 20).

### 15.3 Proof of fatigue strength

For welded joints subjected to mainly dynamic loads, the permissible loading shall be determined by reference to the number of load alternations, the global loading conditions, the mean stress and the notch category (proof of fatigue strength). The notch category is a function of the geometrical configuration of the welded joint. It is also associated with (graduated degrees of) proof of the absence of serious internal and external notches (welding defects see Chapter 1 - Hull Section 3, D).

## H. Execution of Welds

### 1. General

1.1 The general rules prescribed and the instructions given in Section 8 for the execution of welds shall be complied with.

1.2 For the necessary approvals, inspections and tests of welding shops, welders, welding procedures, welding consumables and auxiliary materials, overweldable shop primers, etc., see the relevant sections and also A. to F. of this section.

### 2. Welders and Supervisors

2.1 Welding work on components governed by these Rules may only be performed by qualified welders who have been approved by **TL** and hold valid qualification certificates. Welders and operators (see 2.3 and 2.4) shall be adequately experienced in the practice of the craft.

2.2 Welders for manual and semi-mechanized welding of normal-strength hull structural steels must be qualified for the relevant welding process and welding positions on both butt welds and fillet welds in accordance with Section 3. Welders for vertical-down welding must also be qualified for this position.

2.3 Welders working with higher-strength hull structural steels, special structural steels, stainless steels or aluminium alloys must be qualified for welding these materials in analogous manner to the provisions of Section 3.

2.4 Operators for fully mechanized and automatic welding equipment must have received instruction and training in the use of the equipment and must be qualified. **TL** may demand that the operators' qualifications be verified in the course of the welding procedure test (see Section 4) or by means of production tests during fabrication.

2.5 Every workshop which performs welding work must have a welding supervisor who is an employee of the workshop, proof of whose technical qualifications shall be furnished (see Section 2). **TL** is to be automatically informed of any changes to the welding supervisors.

2.6 The welding supervisor shall supervise the preparation and performance of the welding work in a responsible manner (see C.). Wherever these differ from the preceding and following conditions, requirements, etc., he shall take steps to ensure that the quality of the welded joints is consistent and adequate in consultation with **TL**.

## 3. Weld Preparation and Assembly

### 3.1 Overweldable shop primers

3.1.1 Only those overweldable shop primers may be used for which **TL** has issued a confirmation of acceptability based on a porosity test. See also Section 6.

3.1.2 By means of suitable checks carried out in the course of production (e.g. measurements of coat thickness, production tests), workshops using shop primers shall ensure that the conditions of use on which the

confirmation of acceptability was based are adhered to and that, in fillet welding, no excessive pore formation occurs which adversely affects the application. See also Section 6 (notes).

### 3.2 Weld shapes, root openings (air gaps)

**3.2.1** When preparing and assembling components, care shall be taken to ensure compliance with the weld shapes and root openings (air gaps) specified in the manufacturing documents. With single- and double-bevel welds especially, attention shall be paid to an adequate root opening in order to achieve sufficient root penetration (see G.10.2.1 and G.10.2.2).

**3.2.2** The root opening shall not exceed twice the specified gap. If the size of the gap permitted by this rule is exceeded locally over a limited area, the gap may be reduced by build-up welding of the side walls, subject to the prior consent of the Surveyor. With fillet welds, the "a" dimension shall be increased accordingly, or a single- or double-bevel weld shall be used if the air gap is large. See note to 3.3.2.

**3.2.3** With the Surveyor's agreement, large gaps may be closed by means of a strip of plate with a width of at least ten times the plate thickness or 300 mm, whichever is the greater (see G.4.).

### 3.3 Alignment of components, edge misalignment

**3.3.1** Components which are to be united by butt joints shall be aligned as accurately as possible. Sections etc. welded to plating shall be left unfastened at the ends for this purpose. Special attention shall be paid to the alignment of (abutting) girders etc. which are interrupted by transverse members. If necessary, such alignment shall be facilitated by drilling check holes in the transverse member which are later seal-welded.

**3.3.2** The permissible edge misalignment depends on the importance and loading of the component concerned (weld quality, see I.6.1). With heavily loaded seams (weld quality grade 1) running transversely to the main direction of loading, the edge misalignment of butt

welds shall not exceed 10 % of the thickness of the plate or section, subject to a maximum of 3 mm.

**Note:**

*A serviceable guide to permissible fabricating tolerances is provided in the standards ISO 5817 relating to steel and ISO 10042 relating to aluminium and also in the IACS "Shipbuilding and Repair Quality Standard". In the case of the standards, the assessment category or the individual evaluative criteria to be applied to components or welded joints have to be determined by reference to their loading (see Table 12.10).*

*TL has agreed to the "Manufacturing Standard" subject to the reservation that in particular instances, e.g. where important, highly stressed components are concerned or where there is an accumulation of deviations from nominal dimensions, TL may also impose decisions which differ from the Standard and may call for improvements to be carried out. Where TL raises no objection, the provisions of the Manufacturing Standard may therefore be considered to represent the maximum permissible upper limit for deviations from the stipulated dimensions.*

### 3.4 Tack welds, auxiliary fixtures

**3.4.1** Tack welds should be used as sparingly as possible and should be made by trained operators. Where their quality does not meet the requirements applicable to the subsequent welded joint, they are to be carefully removed before the permanent weld is made.

**3.4.2** Clamping plates, temporary ties, aligning pins, etc. must be made of (hull structural) steel of good weldability and should not be used more than necessary. When the components have been permanently welded, they are to be carefully removed to prevent damage to the surfaces of the components.

**3.4.3** Clamping plates, temporary ties, aligning pins, etc. may not be welded to components subject to particularly high stresses (e.g. hatchway corners), nor shall they be welded to the edges of flange plates or, specially, to the upper edges of sheer strakes and continuous hatchway sidecoamings. The same applies to the welding of handling lugs and other auxiliary fixtures.

**3.4.4** Particularly with mechanized welding processes, and invariably when end craters and defects at the start and end of the weld have to be avoided, run-in and run-off plates of adequate section shall be attached to components and cleanly removed on completion of the weld.

#### **4. Weather Protection, Welding at Low Temperatures**

**4.1** The area in which welding work is performed particularly outside is to be sheltered from wind, damp and cold. Where gas-shielded arc welding is carried out, special attention is to be paid to ensuring adequate protection against draughts. When working in the open in unfavourable weather conditions, it is advisable always to dry welding edges by heating.

**4.2** At low temperatures (below 5°C), suitable measures shall be taken to ensure the satisfactory quality of the welds. Such measures include the shielding of components, extensive preliminary heating and preheating, especially when welding with a relatively low heat input, e.g. when laying down thin fillet welds or welding thick-walled components. Wherever possible, welding work should be suspended if the temperature falls below -10°C.

#### **5. Preheating**

**5.1** The need for and the degree of preheating necessary for welding (see Section 9, D.) are governed by a series of factors. These factors differ in their effect in the manner indicated in Section 9, D.2.5 (Table 9.4), i.e. they raise or lower the necessary preheating temperature. For information on the measurement of the preheating temperature and the interpass temperatures to be maintained, see also Section 9, D.

**5.2** Apart from the measures prescribed in 4.1 and 4.2, normal-strength hull structural steels do not normally require preheating. However, with large cross sections (e.g. steel castings or forgings) and where difficult conditions with regard to design or welding practice apply (e.g. severe distortion of components), it

is advisable to carry out uniform preliminary heating of the areas surrounding the welded joints. See 4.1 and 4.2.

**5.3** Higher-strength hull structural steels shall generally be preheated if the temperature of the work-piece is less than +5°C. If it is higher than this, preheating shall be carried out upwards of a specific threshold wall thickness, paying due regard to the other factors described in Section 9, D.2.5 (Table 9.4). For an average carbon equivalent and an average heat input (energy applied per unit length of weld), the threshold wall thicknesses "t" and preheating temperatures "T" shown in Fig. 12.37 may be used as an initial guide. These values, however, are governed by the influencing factors shown in the above-mentioned Table 9.4 and have to be adjusted in line with the prevailing conditions. Where necessary, the need for and degree of preheating shall be determined in accordance with Section 9, D. or by means of tests (e.g. during the welding procedure tests).

**5.4** Tack and auxiliary welds shall be executed to a length of at least 50 mm and require preheating whenever it has to be carried out for the other welds. Exceptions to this are tack and auxiliary welds whose heat-affected zone is reliably and completely remelted during subsequent welding, e.g. tack welds for submerged-arc welding.

**5.5** Preheating shall be applied uniformly throughout the thickness of the plate or component and to a distance of 4 times the plate thickness, but not more than 100 mm, on both sides of the weld. Localized overheating is to be avoided. Preheating with gas burners should be performed with a gentle, though not sooty, flame. The preheating temperature shall be kept constant throughout the duration of the welding work.

#### **6. Welding Positions, Vertical-Down Welding**

**6.1** Welding should be performed in the optimum welding position, and positional welding (e.g. in the PE or PD (overhead) positions) shall be limited to the indispensable minimum.



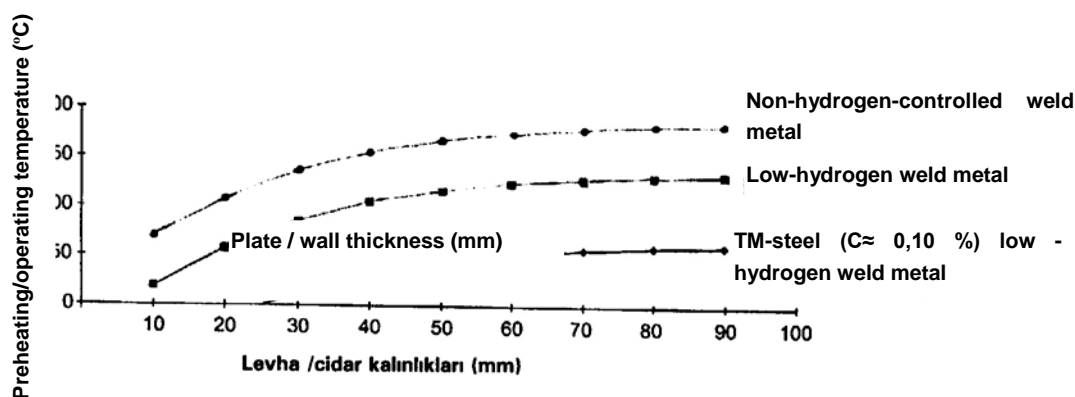

**Fig. 12.37 Threshold wall thicknesses and preheating temperatures for higher-strength hull structural steels (guide values)**

**6.2** For similar and repetitive welding operations, it is advisable to use a (rotating) fixture enabling all welds to be made as far as possible in "simple" positions, such as the flat (PA) or horizontal vertical (PB) position

**6.3** Even after a satisfactory welding procedure test and approval of the process vertical-down fillet welding may not be used:

- For joining together continuous primary supporting members interrupted by transverse members (e.g. the longitudinal members of the upper and lower girder); the same applies where transverse loads predominate,
- For mainly dynamically loaded welded joints (e.g. in the area of engine baseplates, shaft brackets and rudders),
- On crane components and other lifting gear including their substructures (e.g. crane pillars),
- At intersections of main girders and in the area of the supports or stoppers of hatchway covers.

**Note:**

*Vertical-down welding may be used for joining secondary components (e.g. stiffeners) to primary supporting members, for fillet-welding floor plates to continuous bottom longitudinal girders, for fillet-welding transverse bulkheads to the shell plating, and for between-decks, interior partitions, etc. which do not affect the longitudinal or local strength of the vessel. In case of doubt, the extent of the vertical-down welding shall be agreed with TL.*

**6.4** TL may permit exceptions to the provisions of 6.3 and increase the extent of vertical-down welding if the welding shop takes special measures to ensure a satisfactory standard of workmanship (particularly the accurate assembly of components without any significant air gaps, adequate root penetration and prevention of lack of fusion defects) even under normal conditions of fabrication. Such measures include:

- Choosing a suitable welding process and appropriate welding consumables and auxiliary materials which guarantee especially good penetration (see F.1.1),
- Special training and careful selection of welders for vertical-down welding (see also 2.2),
- Conscientious monitoring of the weld preparation, the welding parameters and the welding work (e.g. electrode control) while welding is in progress,
- Production tests at random (fillet weld fracture specimens) during the course of fabrication.

TL may demand proof that special measures of this kind have been taken. In addition, TL may require more extensive monitoring or inspections of the vertical-down welds.

## 7. Welding Sequence

**7.1** The assembly and welding sequence shall be

chosen to allow shrinkage to take place as freely as possible and to minimize shrinkage stresses in the component. Butt joints in areas of plating shall invariably be fully welded, at least on one side, prior to the fastening of girders, stiffeners, etc.

Where individual plates are later welded into position in areas of plating (as in the case of erection holes in the deck or shell plating), the longitudinal seams shall be left unwelded, or shall be opened up, to a distance of approx. 300 mm beyond the transverse joints. The transverse joints shall be welded first, followed by the longitudinal seams.

The welding of patches (see G.4.2) may be performed in analogous manner, unless angular patches with rounded corners or round patches are used.

**7.2** In special cases (e.g. when welding together particularly rigid components) and for similar, repetitive welding operations (e.g. for the welding of masts into ships), it is advisable to set down the assembly procedure or welding sequence in a welding sequence schedule.

**7.3** Where welded and riveted joints meet (the same also applies analogously to other mechanical methods of assembly), the welds shall invariably be completed first, then the riveting adjoining the weld shall be carried out.

## **8. Performance of Work**

**8.1** The areas of the components to be welded must be clean and dry. Scale, rust, cutting slag, grease, paint and dirt shall be carefully removed prior to welding (with regard to overweldable shop primers, see 3.1).

**8.2** Components shall not be subjected to any appreciable movements or vibrations during welding. Parts to be assembled while floating or suspended from cranes shall be clamped prior to the tacking of the joint in such a way that no further movement of the parts is possible. Components which have not been fully welded and are to be handled or turned must have welded joints of adequate strength.

**8.3** Cracked tack welds may not be welded over,

but are to be machined out. In multi-pass welding, the slag of the previous run shall be completely removed before the next pass. Pores, visible slag inclusions and other welding defects and cracks may not be welded over, but are to be machined out and repaired.

**8.4** The welding shop shall ensure that the specified welding parameters are adhered to and that the welding work is expertly performed by competent personnel (see 2.5 and 2.6).

**8.5** Welds must have sufficient penetration and must display a clean, regular surface with "gentle" transitions to the base material. Excessive weld reinforcements and undercuts (see note to 3.3.2) together with notches affecting the edges of plates and cutouts are to be avoided.

**8.6** Butt-welded joints must display full fusion over the entire cross section, unless a deviation from this is authorized in a particular case. For this purpose, the root shall normally be grooved and capped.

Following a successful welding procedure test confirmed by **TL**, single-side welds, e.g. using ceramic backings, may be regarded as equivalent to butt welds executed from both sides.

Other joints welded on one side only, e.g. using permanent backings, are subject to approval by **TL** when scrutinizing the relevant drawings. For the evaluation of such welded joints see G.10.3.

**8.7** Single- and double-bevel welds are to be made according to the design specification either with grooved roots as full-penetration welded joints or with a permitted incomplete penetration at the root or a defined, unwelded root face subject to the appropriate reduction factors (see G.10.2). The type of weld is to be specified in the drawings in each case and must have received **TL**'s approval when the drawings were scrutinized.

**8.8** With fillet welds, particular attention shall be given to good root penetration. The penetration must extend at least to the immediate vicinity of the theoretical root point (see G.10.3.4). The ideal fillet weld section is that of an equal-sided flat-faced weld with smooth (notch-free) transitions to the base material. At

the ends of web plates, at cutouts and at welding apertures, the fillet welds shall meet to form a continuous seam around the root face.

**8.9** Major cases of faulty workmanship or defects in the material may only be repaired with the Surveyor's agreement. Minor surface defects shall be removed by shallow grinding. Defects which penetrate more deeply into the material (e.g. cracks, or tears left by the removal of welded-on erection aids) shall be cleanly machined, ground and repair-welded with an adequate heat input.

## 9. Welding of Higher-Strength Hull Structural Steels and High-Strength (Quenched and Tempered) Fine-Grained Structural Steels

### *Preliminary remark:*

*The following provisions apply in analogous manner to the welding of low-alloy steels tough at subzero temperatures used for structural members in shipbuilding, e.g. for cargo tank supports on gas tankers. The tanks themselves are subject to the Rules for Construction of Seagoing Ships, Chapter 10 - Liquefied Gas Carriers and also Section 14*

**9.1** The steelmaker's instructions and recommendations and any conditions arising from the welding procedure test shall be implemented when welding higher-strength hull structural steels and high-strength (quenched and tempered) fine-grained structural steels.

**9.2** The welding process, welding consumables, weld build-up and thermal practice (preheating, heat input and interpass temperature) etc. shall be suited to the base material being welded and shall be maintained within the appropriate limits during welding. These parameters must match those used during the welding procedure test. Any appreciable deviations require TL's consent and are normally contingent on additional tests. Wherever possible, multi-pass welding shall be used (particularly for high-strength (quenched and tempered) fine-grained structural steels), the final pass being laid down as a "temper bead" run some 2 mm away from the base material.

**9.3** When welding high-strength fine-grained

structural steels it may be necessary to verify not only the preheating but also the heat input during welding **(1)** and the interpass temperatures. These checks shall invariably be carried out and recorded when welding high-strength quenched and tempered fine-grained structural steels. The values must correspond to the energy per unit length of weld established during the welding procedure tests and to be laid down in the welding schedule.

**9.4** Special attention is to be paid to the generally more sensitive hardening properties and the increased notch sensitivity of higher-strength steels, and especially of high-strength fine-grained structural steels. Unnecessary arc strikes on the surface of the plate, scarring of exposed edges, etc. are to be avoided at all costs. Where necessary, such blemishes shall be cleanly ground out and inspected for incipient cracks. The same applies analogously to auxiliary welds.

**9.5** Additional thermal treatments involving a high heat input (e.g. flame gouging and flame straightening) shall not impair the properties of the materials and welded joints and shall, if necessary, be avoided completely. In doubtful cases, proof of the satisfactory performance of thermal treatments may be demanded.

### *Note:*

*Standard flame straightening carried out on higher-strength hull structural steels up to and including E 36 may generally be regarded as acceptable provided that the straightening temperature does not exceed 700°C and that localized overheating or heating of the whole area over a longer period of time (e.g. using heating blocks) and abrupt cooling (e.g. with water) are avoided. The same applies in analogous manner to the flame straightening of thermo-mechanically rolled (TM) steels. Prior to flame straightening of high-strength (quenched and tempered) fine-grained structural steels, special agreement with the steel manufacturer is required.*

**(1)** Determination of heat input (energy applied per unit length of weld):

$$E = \frac{U[\text{volts}] \cdot I[\text{amps}] \cdot \text{welding time} [\text{min}] \cdot 6 \left[ \frac{\text{kJ}}{\text{mm}} \right]}{\text{length of weld} [\text{mm}] \cdot 100}$$

## 10. Welding of Stainless and Clad Steels

**10.1** During the entire construction period, suitable measures shall be taken in transport, storage and fabrication to keep the surface of stainless steels free from impurities and extraneous metallic inclusions (due to abrasion from other components or auxiliary erection supports).

**10.2** Welding processes and welding consumables shall be selected with due regard to strength and corrosion aspects, taking into account the recommendations of the makers of the steel and the welding consumables. Unalloyed welding consumables may not be used for welding stainless steels.

**10.3** Edges are to be prepared mechanically by cutting or planing. Where a thermal cutting technique such as plasma cutting has to be employed, the edges shall subsequently be machined clean.

**10.4** Clad plates shall invariably be tack-welded on the "black" side of the support material. Back-up plates are to be used sparingly and must be made of the material to which they are to be welded.

**10.5** On the side of the cladding and at the corner joints of clad plates (as in the case of drain wells), at least two layers of stainless weld metal are to be laid down over the support material (see G.10.1.6).

Where necessary, different welding consumables shall be used for the intermediate and final runs depending on the base material.

**10.6** Fused weld spatter is to be avoided for reasons of corrosion. Such fusion can be prevented by applying suitable media (e.g. milk of lime) to the surface of the plate on both sides of the weld. Where necessary, weld spatter is to be machined off and the area ground smooth.

**10.6** To achieve corrosion-resistant seams, post-weld treatment (pickling or passivation) shall be carried out in accordance with the instructions issued by the steelmaker or the manufacturer of the welding consumables.

## 11. Welding of Steel Castings and Forgings

**11.1** With steel castings and forgings of large section, difficult welding or structural conditions, heavily distorted members and low workpiece temperatures, a sufficient area surrounding the welded joint shall be uniformly preheated throughout the section.

**11.2** Welding operations on steel castings and forgings shall be performed continuously and without interruption, if possible in a single heating cycle. Cooling shall take place gradually and appropriate measures shall be taken to prevent over-rapid cooling (screening, wind protection).

**11.3** Repair welds (production welds) on steel castings and forgings may only be undertaken with the Surveyor's consent. Where the work concerned is relatively extensive, sketches and a description of the repair shall be submitted to TL head office for approval, together with details of the welding process, welding consumables and auxiliary materials, heat treatment and composition of the base material.

**11.4** TL may stipulate stress relief heat treatment or, in special cases, normalizing heat treatment of the components after welding (e.g. for rudder-stocks). The preliminary remark to Section 5, B. applies in analogous manner to the necessary proof of the properties of the welded joint in heat-treated condition.

**11.5** Welds uniting hull structural steels or comparable forged or cast steels on the one hand to austenitic stainless steels on the other may not be heat-treated. The same applies in analogous manner to build-up welds made with austenitic stainless welding consumables (e.g. on rudderstocks, pintles, etc.). Any post-weld heat treatment which may be required for buildup welds made with other (e.g. heat-treatable) welding consumables shall be specified on a case-by-case basis.

## 12. Welding of Aluminium Alloys

**12.1** The foregoing provisions relating to the welding of steels apply in analogous manner to the welding of aluminium alloys above and beyond the provisions stipulated in the following items. Special

attention is to be paid to cleanliness, thorough degreasing and the avoidance of extraneous metallic impurities. For the use of various types of steel-aluminium welding transition joints (especially the thermosensitivity of the boundary layer between the steel and aluminium), see TL's working sheets.

**12.2** As a rule, welding grooves are to be thoroughly cleaned (e.g. with solvents and/or brushes) immediately before welding. Tools and equipment shall not be used for working on other materials and shall not themselves leave behind extraneous metallic residues. Welding grooves, welding consumables and auxiliary materials must at all costs be dry before welding begins.

**12.3** Welded joints on aluminium alloy structural components used in shipbuilding shall, wherever possible, be made by inert gas welding (MIG welding, or, possibly, TIG welding for small components) performed in welding bays protected from the weather. The weld pool must be safely shielded by an adequate supply of inert gas. Winds and draughts are to be avoided. Care shall be taken to achieve the optimum welding speed and to minimize the effect of the heat on the base material (softening).

**12.4** To avoid end-crater cracking, especially when making intermittent fillet-welded joints, it is advisable (unless welding equipment with crater-filling devices is used) to retract the bead somewhat prior to withdrawal of the electrode or torch so that the end crater is moved back from the end of the seam to a point on the weld and to fill the crater.

**12.5** Extensive preheating of the faces to 100 °C - 200 °C is recommended when welding thick aluminium alloy plates and sections. The welds are to be executed in a suitable sequence, smoothly and speedily and, if possible, without a break.

**12.6** Cold straightening operations should be performed only by pressing, not by hammering. Hot straightening may only be carried out on alloys suitable for that purpose in accordance with the aluminium producer's instructions. Heating and straightening are to be performed speedily. Temperatures are to be carefully monitored so as to prevent fusion of the material.

### **13. Underwater Welding**

**13.1** Under certain conditions, TL may approve the welding (normally fillet welds) of components made of normal-strength hull structural steels which have water behind them. The temperature of the water or component should not be less than 5 °C. The welding point must be dry and clean. At least two passes must be laid down, the last of which shall be run as a "temper bead" over the first pass which has been deposited on the "cooled" component such that it performs a "post-weld heat treatment" function. Welds executed in this manner shall be subjected to a crack test.

**13.2** As a general principle for underwater welding, only those welding processes and/or welding consumables that guarantee a low hydrogen content in the weld metal shall be used. Welding should be performed in a dry environment (chamber pressurized to 1 bar or high-pressure chamber). The above applies in analogous manner to the temperature of the component, the welding point and the crack test. For the required welding procedure tests, see F.

**13.3** Underwater arc welding in which the arc burns in the water or in a small gas vessel and where allowance has to be made for a large amount of hydrogen entering the weld metal may only be used with the explicit authorization of TL in each individual case (even if welding procedure approval has been granted) and then only for temporary repairs (e.g. sealing welds) to components which are subjected to relatively low loads. Welds executed in this manner shall be replaced by normal welds at the next available opportunity and until such a replacement is made TL may prescribe restrictions in the operation of the vessel (e.g. in the operating area).

#### **I. Inspection of Welded Joints**

##### **1. General**

**1.1** In addition to the following provisions, the inspection of welded joints in shipbuilding is governed by the provisions of Section 10 concerning the preparation and performance of non-destructive weld tests.

**1.2** As stipulated in Section 10, D., an inspection schedule shall be submitted to **TL** for approval before commencing the tests. **TL** reserves the right to modify this schedule even after it has been approved, and in particular to extend the scope of the tests and/or change the individual testing positions if necessitated by fabrication operations and/or test results.

## **2. Workshop Inspections, Visual Examination**

**2.1** Workshop inspections are to be carefully performed by trained personnel (e.g. welding supervisors, see C. and H.2.) to ensure the professionally competent and satisfactory execution (appearance and dimensional accuracy) and the integrity of the welds.

**2.2** After welding operations have been completed and subjected to workshop inspection, the work shall be presented to the Surveyor for checking at suitable stages of fabrication. For this purpose, welds shall be readily accessible and shall normally be un-coated. Wherever possible, the results of non-destructive tests shall be presented at this juncture.

**2.3** Where the previous inspection has been inadequate, the Surveyor may reject components and require that they be presented again after satisfactory workshop inspection and any necessary repair work has been performed.

## **3. Non-Destructive Tests**

**3.1** The necessary weld quality as stipulated in Table 12.10 shall be attested by non-destructive tests, the scope of which shall be at least that specified in 6. Should these tests reveal defects of any considerable extent, the scope of the tests shall be increased. Unless otherwise agreed, tests shall then be performed on two further sections of weld of the same length for every weld section tested and found to be in need of repair. Where it is not certain that a defect is confined to the section of weld under test, the adjoining weld sections shall be additionally tested.

**3.2** **TL** may stipulate further tests, especially in the event of doubts as to the professionally competent and satisfactory execution of the welds. For the purpose of monitoring and, where necessary, giving instruction to welders, it is recommended that from time to time

radiographic inspections should also be carried out on components which are not subject to regular testing.

**3.3** The method of inspection to be applied in each instance shall be selected with due consideration for the test conditions (shape and dimensions of the weld, nature and location of possible defects, accessibility) so that any defects may be reliably detected. The method of inspection requires **TL**'s agreement. **TL** may stipulate that two or more inspection techniques be used in conjunction.

**3.4** Subject to the provisions of Section 10, the testing appliances and equipment used shall conform to modern technical practice and the relevant standards.

The tests are to be performed by properly qualified and experienced testers. For details of the prescribed proof of qualification of ultrasonic testers see Section 10, C.1.).

## **4. Production Specimens**

**4.1** Production specimens, i.e. test pieces welded simultaneously at specified intervals during fabrication, may be called for where the base material, the welding process and/or the loading conditions require proof to be provided that the mechanical or other characteristics of the welded joints made under fabrication conditions are adequate.

**4.2** Production specimens shall be welded and tested in a manner analogous to that prescribed in Section 4 in connection with welding procedure tests. The scope of the tests and the requirements to be met shall be determined on a case-by-case basis. For production specimens in connection with shop primers, see Section 6, C.

## **5. Leakage Tests**

**5.1** Where required, leakage tests on welded seams are normally to be carried out in accordance with the Chapter 1 - Hull, prior to the application of any paint or cement.

**5.2** In special cases, and with the approval of **TL**,

the hydrostatic tests stipulated for the leakage tests may be replaced by other methods (e.g. testing under compressed air or vacuum, gas detection method). **TL** may call for such methods as an alternative or in addition to that stipulated.

## 6. Weld Quality Grades, Scope of Tests, Test Methods, Requirements

**6.1** According to the nature and severity of the applied loads and their role in ensuring the soundness of the overall structure, welded joints are to be classified by reference to the influencing factors, their materials, design and service environment (e.g. operating temperature) into one of the three weld quality grades shown in Table 12.10 and shall be identified in the inspection schedule.

**6.2** The individual welded joints are to be classified into quality grades according to their position in the component concerned, i.e. their position in relation to the direction of the main stress, as illustrated by the examples cited in Table 12.10. Components and welded joints not mentioned in the Table 12.10 or in 6.5 shall be classified in an analogous manner.

**6.3** The scope of the non-destructive tests to be applied to welded joints with quality grade 1 (radiographic and ultrasonic inspection) shall be determined by the following formula according to the type and construction of the ship. The number "A" of test positions to be determined refers in the first place to radiographs with a (film) length of 480 mm. Where, in accordance with 6.10 or 6.11, ultrasonic tests are performed instead of radiographic inspection, 1 metre of weld is to be tested in each case in place of the 480 mm length of film

$$A = 0.8 \cdot A_L \cdot c_p \cdot (A_B \cdot c_B + A_H \cdot c_H)$$

where;

$$A_L = L / (16 \cdot a_0)$$

$$L = \text{Length of ship in [m]}$$

$$a_0 = L / 500 + 0.48 \leq 1.0 \text{ [m]}$$

$$c_p = 1.5 \quad \text{With transverse frame construction}$$

$$c_p = 2.0 \quad \text{With mixed transverse and longitudinal frame construction (in the area of the upper and lower girder)}$$

$$c_p = 2.3 \quad \text{With longitudinal frame construction}$$

$$A_B = B/2.5 ; B = \text{Breadth of ship in [m]}$$

$$c_B = 1.0 \quad \text{For single hull tankers and comparable main frame cross sections}$$

$$c_B = 1.3 \quad \text{For dry-cargo freighters and bulk carriers}$$

$$c_B = 1.5 \quad \text{For container ships and double hull (chemical) tankers}$$

$$A_H = H/2.5 ; H = \text{Depth of ship in [m]}$$

$$c_H = 0.5 \quad \text{For dry-cargo freighters}$$

$$c_H = 1.3 \quad \text{For tankers, container ships and bulk carriers}$$

$$c_H = 1.5 \quad \text{For double-hull tankers with additional longitudinal bulkheads}$$

**6.4** The number "A" of test positions determined in accordance with 6.3 shall be distributed in such a way that roughly two-thirds of the number "A" established are positioned on the welded joints with quality grade 1 described in Table 12.10 and roughly the remaining third on those joints with quality grade 2. Appropriate consideration shall be given to the individual components specified in 6.5. Depending on the loading conditions, a different inspection density (a different distribution of the total number of test positions) for the various weld quality grades or components may be expedient or may be demanded by **TL**.

**6.5** The welded joints of the particular components listed below are to be classified and tested as follows:

- Deck stringer/sheer strake joint within 0.5 L of midship: weld quality grade 1, 100 % ultrasonic inspection if full-penetration welding is required in accordance with G. 10.2.1.

- Deck stringer/sheer strake joint outside of 0.5 L of midship: weld quality grade 2, 10 % ultrasonic inspection if full-penetration welding is required in accordance with G.10.2.1.
- Joints between horizontal rudder coupling plate and rudder body (see Fig. 12.35): weld quality grade 1, 100 % ultrasonic inspection and 100 % surface crack inspection.
- Joints between rudderstock and horizontal coupling plate (see Fig. 12.36): weld quality grade 1, 100 % ultrasonic inspection and 100 % surface crack inspection.
- Full-penetration single- and double-bevel T-joints (see Fig. 12.22): weld quality grade 1 or 2 depending on position of weld, 100 % or 10 % ultrasonic inspection respectively.
- Restarting points in electroslag or electrogas welds: weld quality grade 1 or 2 depending on position of weld, 100 % radiography or ultrasonic inspection, the latter with the test sensitivity increased by 12 dB (see also Section 4, L.2.5).
- Welds for which proof of fatigue strength is required: weld quality grade and inspection depend on detail category.

**6.6** In the case of ships for which no special proof of (longitudinal) strength has to be submitted (generally ships less than 65 m long; see Chapter 1 - Hull, Section 5), the number "A" (of test positions) may be reduced to 70 % of the figure prescribed in 6.3 and 6.4. The reduction shall be agreed with **TL** in every case and is to be specially indicated in the inspection schedule.

**6.7** Where the conditions of fabrication remain unchanged, i.e. where to a large extent the same welders are employed in welding the same or similar components (e.g. in repetition shipbuilding) by means of the same welding processes, welding consumables and auxiliary materials, **TL** head office may consent to a reduction of the scope of inspection specified in 6.3 and 6.4. This is conditional on proof being supplied of uniformly good results and a relatively low incidence of

repairs, as attested by the results of all initial inspections performed on welded joints prior to any repairs.

**6.8** Where radiographic inspections are performed randomly, they are to be carried out chiefly at the intersections of longitudinal seams and transverse joints, at sectional joints and at joints presenting difficulty or requiring to be welded in a fixed position. Joints in girders and stiffeners are to be classified similarly to those in plating and are to be included in the inspection.

**6.9** Ultrasonic tests may be performed in place of a proportion (to be specified in every case) of the number of radiographs prescribed in 6.3 and 6.4. For wall and plate thicknesses of 30 mm and over, ultrasonic testing is to be preferred to radiography as a method of inspection.

**6.10** In special cases, ultrasonic tests may be stipulated as an alternative, or additionally, to radiographic inspection, e.g. where certain defects, owing to their nature and location or to the configuration of the weld, cannot be sufficiently reliably detected or assessed by radiography.

**6.11** Surface crack inspections shall generally be carried out following the welding of large sections particularly those of steel castings and forgings as well as in the case of welds made under stress or at low temperatures, large-volume single- or double-bevel welds (plate thicknesses of about 30 mm and over) and thick fillet welds, e.g. on stern posts, after welding-in of masts and welds on bulkhead stools.

**6.12** For the inspection of particular components and their welded joints, see 6.5. **TL** may, in addition, call for further tests in conjunction with the approval of drawings.

**6.13** Welded joints and components not covered by the foregoing provisions shall undergo non-destructive tests whose scope shall be specified in each individual case. Where certain components (e.g. the masts of cargo handling gear, liquefied gas tanks and the pressure hulls of underwater vehicles) are governed by special rules or codes of practice, the provisions contained in these shall be implemented.



Table 12.10 Weld quality grades, scope of inspection, requirements

Weld quality grade	1	2	3
Loading, importance	Welded joints which are subjected to severe static or mainly dynamic stresses and/or which are essential to the soundness of the overall structure.	Welded joints which are subjected to medium stresses and/or whose failure entails the loss of function of individual components without endangering the structure as a whole.	Welded joints which are subjected to minor stresses and/or whose failure does not entail the loss of function of important components.
Components, position of welded joints (for individual details relating to particular components and welded joints, see 6.5)	<p>Transverse joints in the area of the upper and lower flange plate <b>(1)</b> within 0,5 L of midship <b>(2)</b>, e.g. in the outer bottom incl. bilge strake, longitudinal girders, longitudinal frames, strength deck incl. sheer strake. Longitudinal girders and beams, longitudinal bulkheads incl. longitudinal stiffeners, hatchway side coamings incl. longitudinal stiffeners.</p> <p>Joints in shell plating and strength deck in the immediate vicinity of fittings and fixtures (traversing the plate), e.g. rudder heels, masts including the welds uniting them to the first-named items. Joints in the flanges and webs of main girders, e.g. in hatchway covers, hatch or cantilever girders and in cantilever masts. Joints in tank bulkheads and the bottom structures of bulk carriers including the bulkhead stools.</p> <p>Joints in or on components subjected mainly to dynamic loads, e.g. shaft struts, rudder heels, rudder couplings, (connecting them to the rudder body) and the main girders of engine beds.</p>	<p>Longitudinal bulkheads <b>(3)</b> in the area of the upper and lower hull flange plate, transverse joints in the area outside 0,5 L of midship <b>(2)</b>, and joints in the rest of the shell plating and in the double bottom.</p> <p>Joints in watertight transverse bulkheads of dry-cargo freighters and in web frames.</p> <p>Joints in hatchway covers, end bulkheads of superstructures and deckhouses, and joints in transverse girders.</p>	Joints in subordinate components such as decks, partitions and their stiffeners not included in the main strength structure, decks of super-structures and deck-houses, joints in bulwarks, etc.
Scope and method of inspection	<p>Visual inspection and random dimensional checks.</p> <p>Non-destructive tests in accordance with 6. (random checks with greater intensity of inspection).</p> <p>Leakage and other tests, where required.</p>	<p>Visual inspection, random dimensional checks in cases of doubt.</p> <p>Non-destructive tests in accordance with 6. (random checks with lesser intensity of inspection).</p> <p>Leakage and other tests, where required.</p>	<p>Visual inspection</p> <p>In cases of doubt, non-destructive tests in accordance with 6.</p> <p>Leakage and other tests, where required.</p>

**Table 12.10 Weld quality grades, scope of inspection, requirements (continuous)**

Weld quality grade	1	2	3
Requirements, weld quality (4)	Welded seams to be free from cracks, lack of fusion and root defects, slag lines, coarse pore clusters and slag inclusions, prominent undercuts, etc. in conformity with assessment category B in accordance with ISO 5817 relating to steel and ISO 10042 relating to aluminium, as applicable) (5).	Welded seams to be free from cracks, major lack of fusion and root defects, long slag lines, coarse slag inclusions, uninterrupted pores, coarse pore clusters, major undercuts, etc. in conformity with assessment category C in accordance with ISO 5817 relating to steel and ISO 10042 relating to aluminium, as applicable (5).	Welded seams to be free from cracks, major root defects and slag inclusions, uninterrupted pores, severe undercutting, etc. in conformity with assessment category D in accordance with ISO 5817 relating to steel and ISO 10042 relating to aluminium, as applicable (5).
<p>(1) <i>In accordance with the Chapter 1 - Hull, this is the area extending to at least 0.1 H and 0.1 H' above and below respectively. The inspection shall, however, invariably cover the entire sheer strake and bilge strake area together with continuous longitudinal members (e.g. hatchway side coamings and crane rails) above the strength deck. Where partial use is made of higher-strength steel, the inspection shall embrace the whole area of this steel in terms of height, and in the case of container ships and similar vessels it shall cover the entire area of the upper box girders.</i></p> <p>(2) <i>In ships with large deck openings, i.e. ships with large hatches (such as container ships), the transverse joints in the upper hull girder flange fore and aft of 0.5 L (generally the entire hatchway area) shall also be assigned to weld quality grade 1 where necessary (e.g. because of the torsional stresses imposed).</i></p> <p>(3) <i>At weld intersections the adjoining 300 mm of longitudinal seam are to be classified identically with the relevant transverse joints.</i></p> <p>(4) <i>See also the note to H.3.3.2. Comparable provisions contained in other standards, etc., may also be used for assessment purposes, subject to TL's consent.</i> <i>Where components or welded joints have been dimensioned according to fatigue strength criteria on the basis of a specific detail category <math>\Delta\sigma_R</math>, the quality grade must also meet the requirements of this detail category. Detail category contains instructions for the classification of individual irregularities in correlation to the assessment groups in conformity with ISO 5817 relating to steel.</i></p> <p>(5) <i>With regard to the requirements for ultrasonic testing, see Section 10, L.5 (Table 10.4).</i></p>			

## J. Welding Requirements for Cargo Tanks of Gas Tankers

### 1. Welding and Non-destructive Testing

#### 1.1 General

This sub-section shall apply to primary and secondary barriers only, including the inner hull where this forms the secondary barrier. The requirements listed herein are those generally employed for carbon, carbon-

manganese, nickel alloy and austenitic stainless steels, aluminium alloy and may form the basis for acceptance testing of other material. At the discretion of TL, Charpy V-notch impact testing of austenitic stainless steels and aluminium alloy weldments may be omitted and other tests may be specially required for any material.

#### 1.2 Welding consumables

Welding consumables intended for welding of cargo tanks shall be approved by TL.

Deposited weld metal tests and butt weld tests shall be required for all welding consumables, unless specially agreed otherwise. The results obtained from tensile and Charpy V-notch impact tests shall be approved by **TL**. The chemical composition of the deposited weld metal shall be reported for information and approval.

### 1.3 Welding procedure tests for cargo tanks and process pressure vessels

#### 1.3.1 Number and orientation of test assemblies

Welding procedure tests for cargo tanks and process pressure vessels are required for all butt welds. The test assemblies shall be representative of the following:

- (i) Each base material
- (ii) Each type of consumable and welding process
- (iii) Each welding position

For butt welds in plates, the test assemblies shall be so prepared that the rolling direction is parallel to the direction of welding. The range of thickness qualified by each welding procedure test shall be approved by **TL**. Radiographic or ultrasonic testing may be performed at the option of the fabricator or **TL**.

#### 1.3.2 Required tests

The following welding procedure tests for cargo tanks and process pressure vessels shall be carried out in accordance with Chapter 2, Section 3,E.2, with the specimens made from each test assembly:

- (i) Cross-weld tensile tests
- (ii) Longitudinal all-weld tensile testing, where required by **TL**.
- (iii) Transverse bend tests: which may be face, root or side bends at the discretion of **TL**. However, longitudinal bend tests may be required in lieu of transverse bend tests in cases where the base material and weld metal have different strength levels.
- (iv) One set of three Charpy V-notch impact test specimens, generally at each of the following indications (see Fig. 12.38):

- (1) Centre line of the welds
  - (2) Fusion line (F.L.)
  - (3) 1mm from the F.L.
  - (4) 3mm from the F.L.
  - (5) 5mm from the F.L.
- (v) Macrosection, microsection and hardness survey may also be required at the discretion of **TL**.

### 1.4 Test requirements

#### 1.4.1 Tensile tests

Generally tensile strength shall not to be less than the specified minimum tensile strength for the appropriate parent materials. It may also be accepted subject to agreement with **TL** that the transverse weld tensile strength is not to be less than the specified minimum tensile strength for the deposited metal, where the weld metal has lower tensile strength than that of the parent metal. In every case, the position of fracture shall be reported for information.

#### 1.4.2 Bend tests

No fracture is acceptable after 180° bend over a former diameter of 4t where t is the thickness of the test pieces.

#### 1.4.3 Charpy V-notch impact tests

Charpy V-notch impact test shall be conducted at the temperature prescribed for the base material being joined. The results of weld metal Charpy V-notch impact tests, minimum average energy (KV), shall be no less than 27J. The weld metal requirements for subsize specimens and single energy values shall be in accordance with Chapter 2, Section 3,E.2.2. The results of fusion line and heat affected zone Charpy V-notch impact tests, shall show a minimum average energy (KV), are to be generally in accordance with the transverse or longitudinal requirements of the base material whichever is applicable, and for subsize specimens, the minimum average energy (KV), in accordance with Chapter 2, Section 3,E.2.2. If the material thickness does not permit machining either full size or standard subsize specimens, the testing procedure and acceptance standards shall be approved

by **TL**.

### 1.5 Fillet welding procedure tests

Fillet welding procedure tests shall be in accordance with the Rules of **TL**. In such cases, welding consumables shall be selected which exhibit satisfactory Charpy V-notch impact properties.

### 1.6 Welding procedure tests for secondary barriers

Welding procedure tests for secondary barriers shall be in accordance with the Rules of **TL**.

### 1.7 Welding procedure tests for piping

Welding procedure tests for piping are required and shall be similar to those detailed for cargo tanks provided in 1.3. Unless specially agreed otherwise the test requirements shall be in accordance with 1.4.

### 1.8 Production weld tests

For all cargo tanks and process pressure vessels except for integral and membrane tanks, production tests shall generally be performed for approximately each 50 m of butt weld joints and shall be representative of each welding position. For secondary barriers, the same type production tests as required for primary tanks shall be performed except that the number of tests may be reduced subject to the agreement with **TL**. Tests, other than those specified, may be required for cargo tanks or secondary barriers at the discretion of **TL**. Test requirements shall be in accordance with 1.4.

The quality assurance/quality control programme shall ensure the continued conformity of the production welds as defined in the material manufacturer's quality manual.

#### 1.8.1 Type A and type B independent tanks and semi-membrane tanks

The production tests for type A and type B independent tanks and semi-membrane tanks shall include the following tests:

Bend tests and, where required for procedure tests, one set of three Charpy V-notch impact tests shall be made for each 50 m of weld.

The Charpy V-notch impact tests shall be made with specimens having the notch alternately located in the centre of the weld and in the heat affected zone (most critical location based on procedure qualification results). For austenitic steels, all notches shall be in the centre of the weld.

#### 1.8.2 Type C independent tanks and process pressure vessels

In addition to those tests listed in 1.8.1, for type C independent tanks and process pressure vessels, transverse weld tensile tests are also required.

#### 1.8.3 Integral and membrane tanks

The test requirements for integral and membrane tanks are the same as the applicable test requirements listed in 1.3.

### 1.9 Non-destructive testing

All test procedures and acceptance standards shall be in accordance with **TL**, unless the designer specifies a higher standard in order to meet design assumptions. Radiographic testing shall be used, in principle, to detect internal defects. However, an approved ultrasonic test procedure in lieu of radiographic testing may be conducted, but, in addition, supplementary radiographic testing at selected locations shall be carried out to verify the results. Radiographic and ultrasonic testing records shall be retained. The quality assurance/quality control programme shall ensure the continued conformity of the non-destructive testing of welds, as defined in the material manufacturer's quality manual.

#### 1.9.1 Type A and B independent tanks and semi-membrane tanks

(i) For type A independent tanks and semi-membrane tanks where the design temperature is equal to or lower than  $-20^{\circ}\text{C}$ , and for type B tanks, regardless of temperature, all full penetration butt welds of the shell

plating of cargo tanks shall be subjected to non-destructive testing suitable to detect internal defects over their full length. Ultrasonic testing in lieu of radiographic testing may be carried out under the same conditions as described in the first paragraph of 1.9.

(ii) For type A independent tanks and semi-membrane tanks, where the design temperature is higher than  $-20^{\circ}\text{C}$ , all full penetration butt welds in way of intersections and at least 10% of the remaining full penetration butt welds of tank structures shall be subjected to radiographic testing or ultrasonic testing under the same conditions as described in the first paragraph of 1.9.

(iii) In each case, the remaining tank structure, including the welding of stiffeners and other fittings and attachments, shall be tested by magnetic particle or dye penetrant methods, as considered necessary by TL.

### 1.9.2 Type C independent tanks and process pressure vessels

Inspection of type C independent tanks and process

pressure vessels shall be carried out in accordance with Chapter 10, Section 6.5.

### 1.9.3 Integral and membrane tanks

Special weld inspection procedures and acceptable standards shall be submitted by the designers of integral and membrane tanks for approval by TL.

### 1.9.4 Piping

Inspection of piping is to shall be carried out in accordance with Chapter 10, Section 5.

### 1.9.5 Secondary barriers

The secondary barrier shall be non-destructive tested for internal defects as considered necessary. When the outer shell of the hull is part of the secondary barrier, all shearstrake butts and the intersections of all butts and seams in the side shell shall be tested by radiographic testing.

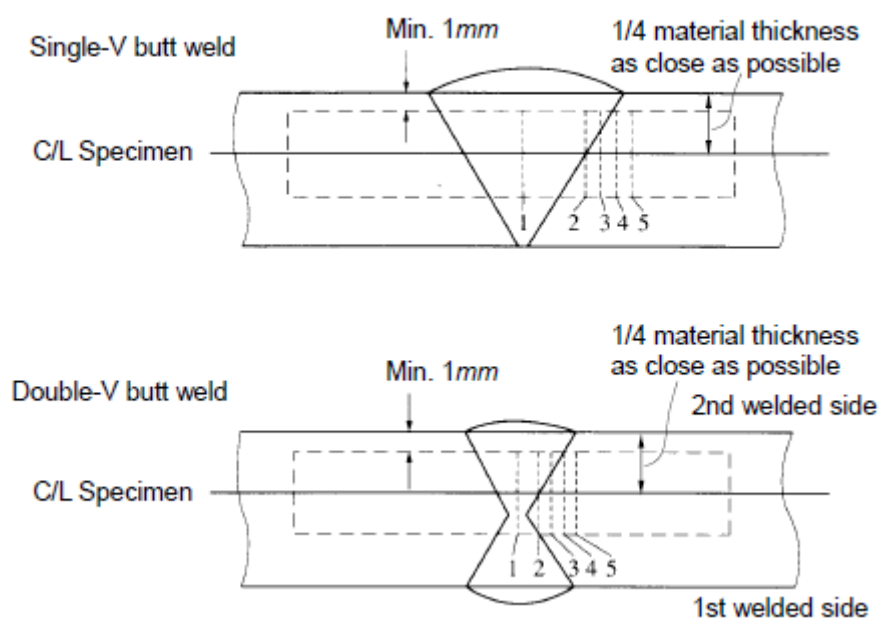

Figure 12.38 Sampling position of Charpy V-notch impact test specimens (Weld)

#### Notch location

- 1 Centreline of the weld
- 2 Fusion line
- 3 In HAZ, 1mm from fusion line
- 4 In HAZ, 3mm from fusion line
- 5 In HAZ, 5mm from fusion line

**SECTION 13****WELDING OF STEAM BOILERS**

	<b>Page</b>
<b>A. GENERAL</b> .....	<b>13-2</b>
1. Scope	
2. Other Relevant Rules	
3. Assessment of Welds	
<b>B. APPROVAL OF WELDING SHOPS, WELDING PERSONNEL</b> .....	<b>13- 2</b>
<b>C. QUALITY INSPECTION, RESPONSIBILITY</b> .....	<b>13- 2</b>
<b>D. MATERIALS, WELDABILITY</b> .....	<b>13- 3</b>
<b>E. WELDING CONSUMABLES AND AUXILIARY MATERIALS</b> .....	<b>13- 3</b>
<b>F. WELDING PROCEDURE TESTS</b> .....	<b>13- 4</b>
1. General	
2. Welding of Test Pieces, Welding Procedure Specification (WPS)	
3. Test Principles, Delimitation of Scope	
4. Tests, Scope of Tests	
5. Test Requirements	
6. Storage of Specimens	
7. Validity, Extension of Welding Procedure Tests	
<b>G. WELDING TECHNIQUE</b> .....	<b>13- 7</b>
<b>H. POST-WELD HEAT TREATMENT</b> .....	<b>13- 7</b>
<b>I. INSPECTION OF WELDED COMPONENTS</b> .....	<b>13-10</b>

**Preliminary remark:**

The following rules relating to the welding of steam boilers comply with or incorporate the Technical Rules for Steam Boilers (TRD). Subject to the approval of **TL**, other codes of practice such as the ASME Boiler and Pressure Vessel Code, Section 1 may also be adopted for the fabrication and testing of welded steam boilers (the following rules being applicable in analogous manner). See also Section 1, B.1.4.

**A. General****1. Scope**

**1.1** These Rules apply to the fabrication and testing of welded steam boilers, superheaters, feed water preheaters and similar pressurized components of the steam boiler installation.

**2. Other Relevant Rules**

**2.1** The provisions of **TL** Machinery Installations Chapter 4, Section 12 shall also be complied with in the design and dimensioning of steam boiler components.

**2.2** For the fabrication and testing of steam boiler installations intended for ships sailing under the Turkish flag, it is essential to comply with the "Technische Regeln für Dampfkessel" (Technical Rules for Steam Boilers) of series TRD 200 in conjunction with series TRD 100.

**3. Assessment of Welds**

**3.1** Tensionally stressed longitudinal welds may generally be assessed with a weld factor up to  $V = 0,8$ , provided that they meet the requirements specified in Section 1 and 2 and the following paragraphs.

**3.2** A higher assessment up to  $V = 1,0$  may be applied if a production test and non-destructive testing in accordance with I.11. have been successfully performed on the finished component.

**B. Approval of Welding Shops, Welding Personnel**

**1.** All welding shops intending to perform welding work within the scope of these rules must satisfy the requirements applicable to welding shops and personnel set out in Section 2 and must have been approved by **TL**. Applications for approval shall be submitted by the welding shops in good time before starting the welding work, enclosing the information and documentation prescribed in Section 2, A.3.

**2.** The welding personnel (welders and welding supervisors) and, where applicable, inspectors and inspection supervisors must satisfy the requirements set out in Section 2, B.2., B.3. and B.4 and be recognized by **TL**. For the welder's qualification tests, see Section 3.

**C. Quality Inspection, Responsibility**

**1.** The manufacturer shall submit to **TL**, for inspection, drawings and other relevant documents containing at least the following information:

- The materials and welding consumables to be used,
- The welding process and the location and shape of the weld,
- The type of heat treatment, if required,
- The acceptable working pressure,
- The design temperature,
- The operating temperature,
- The test pressure,
- The weld factor "V" used as a basis for calculation,

- The nature and scope of the non-destructive tests,
- The nature and scope of the production tests.

2. If the quality or good working order of a component cannot be guaranteed or is in doubt due to inadequate or missing information in the manufacturing documents (e.g. production drawings), TL may demand appropriate improvements.

3. The welding shops shall ensure by means of regular in-house quality inspections during fabrication and on completion of the welding work that this work has been performed competently and satisfactorily (see Section 1, F.). For the duties and responsibilities of the welding supervisor, see also ISO 14731.

4. The welding shops are responsible for ensuring that the welding work conforms to these Rules, the approved manufacturing documents, any conditions stipulated in the approval documents and the latest state of welding practice. The inspections and checks to be performed by the TL's Surveyor do not relieve the welding shops of this responsibility.

5. With regard to quality inspections and the responsibilities involved in awarding subcontracts to independent branches or suppliers or to approved or non-approved outside firms working in the welding shop (subcontractors), see Section 1, F. Subcontracting of work or employment of temporary workers shall be notified to TL.

6. The scope of the required quality inspections depends on the construction project in question. It is essential to ensure, however, that the intended materials, welding consumables and auxiliary materials are used and that the weld preparation, assembly, execution of the tack and final welds and the dimensional accuracy and completeness of the welded joints meets the requirements stated in 3. For non-destructive testing of the welded joints and production tests have to be performed, see I.

7. Following internal inspection and, if necessary, repair by the welding shop, the components shall

be presented to the TL's Surveyor for checking at suitable stages of fabrication. For this purpose they shall be readily accessible and shall normally be uncoated. Where the previous inspection has been inadequate, the Surveyor may reject components and require that they be presented again after satisfactory workshop inspection and any necessary repair work has been performed.

8. TL is not responsible for guaranteeing that all the components and welded joints inspected to the prescribed extent (generally on a random basis) by its surveyors have been fabricated in accordance with the conditions and meet the requirements in every respect. Components or welded joints which subsequently turn out to be defective may be rejected or their repair may be demanded even if acceptance testing has already been carried out.

#### **D. Materials, Weldability**

1. The materials selected must be appropriate for the intended purpose, with allowance made for mechanical and thermal stresses. The characteristics of materials subjected to further processing shall be such that they are able to withstand the operating loads.

2. Welded structures may only be fabricated using base materials of proven weldability. The intended materials must comply with the requirements set out in the relevant sections of Chapter 2, Material. Other comparable materials may only be used after TL has given its approval in each individual case.

#### **E. Welding Consumables and Auxiliary Materials**

1. The welding consumables must enable a welded joint to be made which is appropriate to the base material, the operating temperature and the conditions of service. The suitability of the welding consumables must also have been verified under the conditions prevailing in further processing.



2. All the welding consumables and auxiliary materials used (e.g. covered electrodes, wire-gas combinations, wire-flux combinations, etc.) must have been approved by TL in accordance with Section 5. They may also, however, be approved if tested at the same time as the welding procedure and restricted to the user's works (see Section 4, B.3.2 and Section 5, A.1.4).

3. For joints between different materials, the welding consumable shall wherever possible be geared to the lower-alloyed material or the material with the lower strength.

4. Welding consumables and auxiliary materials specified in a procedure approval document with a maker's or brand name (see F.3.5) may only be replaced by equivalent consumables approved by TL with an appropriate quality grade if this is explicitly stated in the respective approval document. Failing this, the TL's agreement shall be obtained.

5. The welding consumables and auxiliary materials may only be used in the approved welding positions. The manufacturers' recommendations and instructions for welding (e.g. type of current and polarity) shall be followed.

6. The welding consumables and auxiliary materials (especially hydrogen-controlled, basic-covered electrodes and basic welding fluxes) shall be re-dried before use in accordance with the manufacturer's instructions (observe maximum drying time!) and stored in a dry place (in heated containers or the like) at the workplace.

## F. Welding Procedure Tests

### *Preliminary remark:*

*In contrast to earlier issues of these Rules, welding procedure tests shall be performed in accordance with EN ISO 15607-EN ISO 15614, as applicable. This paragraph essentially covers requirements applicable to the welding of steam boilers over and above those set out in EN ISO 15614-1.*

## 1. General

Only those welding procedures shall be employed whose satisfactory operational handling and adequate quality properties have been verified as part of a welding procedure test under production conditions at the user's works. The general requirements set out in Section 4 shall be observed. The welding procedures must have been approved by TL for the particular welding shop in question.

## 2. Welding of Test Pieces, Welding Procedure Specification (WPS)

2.1 A preliminary "manufacturer's" welding procedure specification (pWPS) setting out all the major parameters shall be produced by the welding shop for the welding of test pieces in accordance with EN ISO 15609-1, as applicable.

2.2 TL's expert shall select one of the welders whose names are to be supplied by the manufacturer to weld the test pieces.

2.3 The test pieces shall be made from materials whose properties are proven in accordance with the requirements specified Material Rules Section 3, 4, 5, 6, 7, 10. Their strength shall be at least 40 N/mm<sup>2</sup> higher than the minimum tensile strength of the material group. Pre-treatment and after-treatment of the welded joints by preheating, heat treatment and the like is only permitted if stipulated for these materials during actual fabrication.

2.4 The types of weld and welding positions employed in the fabrication process shall be qualified in the welding procedure test.

2.5 The form and dimensions of the test pieces are specified in EN ISO 15614-1 or, where applicable, stipulated in 2.6.

2.6 For welding of sockets, nipples, etc., the following shall be made:

- 2 socket welds in accordance with standard workshop practice or

- 2 test pieces as shown in Figs. 13.1a) and 13.1b).

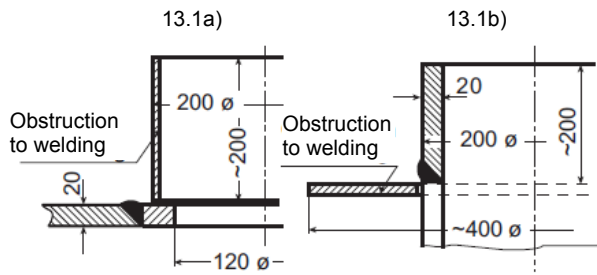

**Fig. 13.1 Test pieces for welding of sockets and nipples, inserted (left) and through-type (right)**

### 3. Test Principles, Delimitation of Scope

The qualification of the welding procedure shall be ascertained in accordance with EN ISO 15607 by means of welding procedure qualification tests, for steel in accordance with EN ISO 15614-1.

The test is valid within the limits described in Items 3.1 to 3.7.

The scope of the welding procedure test is specified by **TL** in writing. Any exceptions require the performance of a supplementary test, the scope of which shall be decided by **TL**. Production tests may be recognized as supplementary tests.

#### 3.1 Material groups

Above and beyond the grouping system of EN ISO 15614-1, the following provisions shall be observed:

**3.1.1** For materials which have to satisfy particular corrosion conditions (e.g. resistance to caustic cracking) the welding procedure tests shall be geared to these.

**3.1.2** A welding procedure qualification performed on group 1 killed steel does not apply to unkilld steels unless they were welded using basic covered electrodes or wire-flux combinations with basic flux.

**3.1.3** The materials 15NiCuMoNb5 and 17MnMoV6-4 shall be classified as group 2 materials.

Approval is also granted for the following further material combinations in addition to those stipulated in EN ISO 15614-1 but under the following conditions (see Table 13.1).

Deviating from EN ISO 15614-1, a welding procedure test available for the combination group 9 welded to group 2 does not incorporate the combination group 9 welded to group 3.

Depending on material composition and/or the type of post-weld treatment required, **TL** may also limit the scope to the base material used in the welding procedure test.

#### 3.2 Welding process

Recognition applies only to the welding process employed in the welding procedure test.

**Table 13.1 Welding procedure qualification available for a steel group or combination joint**

Welding procedure qualification available for a steel group or combination joint	Suitable for the following combination joints
5 (10CrMo9-10) welded with 4	4 welded with 5 (13CrMo4-5) 4 welded with 1 4 welded with 2 ( $R_e < 430 \text{ N/mm}^2$ )
5	5 welded with 1 5 welded with 2
6 welded with 4	6 welded with 5 6 welded with 2 6 welded with 1

### 3.3 Gas welding

In gas welding a test performed on the wall thickness  $t$  shall apply to the wall thickness range  $0,75 t$  to  $1,25 t$ .

### 3.4 Welding parameters

Welding procedure tests performed on multi-pass welds do not apply to single-pass welds.

### 3.5 Welding consumables and auxiliary material

The requirements of EN ISO 15614-1 do not apply if the filler metal used is of the same type and has been approved by TL to be under the scope of the welding procedure qualification (see E.4.).

### 3.6 Heat treatment

The welding procedure test applies to the heat treated condition existing at the time of the test. Heat treatment of the test piece shall be performed so that a heat treated condition is achieved which is comparable to that of the component.

### 3.7 Special cases

For special cases, for example projection welds, welding of clad steels, stud welds and difficult repairs to be performed in the course of fabrication on steels which are susceptible to cracking due to hardening of the heat affected zone, welding procedure tests are necessary which are geared to these particular cases. The tests required and their scope are specified by TL in each individual case.

## 4. Tests, scope of tests

Testing comprises both non-destructive and destructive tests and shall be performed in accordance with EN ISO 15614-1.

Deviating from EN ISO 15614-1, the following specimens shall also be taken from the test pieces:

**4.1** One all-weld metal tensile test specimen with a diameter of 10 mm and  $L_0 = 5 d$  shall also be taken in

the case of test pieces more than 20 mm thick in materials where the effect of the weld metal caused by the welded joints may be significant.

This applies to steels in material groups 4 and 6 and also for the steels specified in 3.1.3.

**4.2** Notched bar impact test specimens shall be taken from the centre of the weld metal for each welding position in the case of:

- Plates: all materials with a nominal wall thickness  $> 5$  mm
- Tubes:
- 14 MoV6-3 and X20CrMoV12-1 with a nominal wall thickness  $> 10$  mm,
- 16 Mo 3 with a nominal wall thickness  $> 20$  mm,
- All other grades of steel conforming to EN 10216-2 and EN 10217-2 with a nominal wall thickness  $> 30$  mm,
- Other grades of steel above the nominal wall thicknesses as specified in the standards or in TL approval document for the base material.

**4.3** Micrographic specimen for alloy steels (1). The structure shall be described and verified by means of photographs.

**4.4** Analysis of the weld metal for alloy steels (1).

## 5. Test Requirements

The irregularities in the test piece must fall within the limits specified for quality level B in accordance with ISO 5817, exceptions being: excessive weld reinforcement (butt and fillet welds), excessive root reinforcement and excessive fillet weld thickness which fall into quality level C.

(1) *For the classification of steels (unalloyed and alloyed), see EN 10020.*

For the mechanical and technological tests, Table 13.2 applies.

#### 6. Storage of specimens

The tested specimens and the remaining portions of the test pieces shall be stored until the report on the welding procedure test has been completed (see also, Section 4, C.3.).

#### 7. Validity, extension of welding procedure tests

The validity of a welding procedure test is generally 1 year provided that the preconditions under which it was granted have not significantly changed. It may be continued by means of regular production tests (see I.11).

In addition to production tests and tests performed on welded components (see I.) non-destructive tests may, given certain preconditions, also be recognized by TL for continuing the validity.

The welding procedure test shall be repeated if there is a break in the fabrication of steam boilers or steam boiler components lasting longer than one year.

#### G. Welding Technique

1. Welds must exhibit full penetration over their entire cross section and must not have any cracks or lack of fusion defects. Wherever possible, the root shall be grooved and capped.

2. When welding plates whose thicknesses differ by more than 20 % or more than 3 mm, the thicker plate shall be bevelled to the thickness of the thinner plate at a maximum angle of 30°.

3. In the case of shells consisting of several rings, the longitudinal seams shall be staggered.

4. Fillet welds on lapped joints are only permitted in special cases and are then to be made only as double-sided circumferential welds up to a wall thickness of 15 mm.

5. Corner welds and similar welded joints which are subjected to considerable flexural stresses under adverse conditions of fabrication or service are only allowed if TL raises no objection to the method of execution.

6. Holes and cut-outs in or immediately adjacent to welds, especially longitudinal welds, shall be avoided wherever possible.

7. Welding of components in cold-formed areas where the outer fibres have been stretched by more than 5 % ( $D_m < 20 \times s$  for cylindrical shell rings) is only allowed if the effects of cold-forming have been eliminated by means of appropriate heat treatment.

This generally has to be accomplished by normalizing heat treatment or quenching and tempering. This requirement may be waived if proof is furnished that the properties of the material are no more than insignificantly impaired with regard to the intended use.

8. Every weld in a boiler component shall be marked in such a way that its location remains recognizable and the welder concerned can be identified at any time. Both of these may be evidenced either by stamping the weld accordingly or by making entries in drawings, welding schedules or other records.

#### H. Post-Weld Heat Treatment

1. Welded components must be heat-treated after welding in accordance with the stipulations of the relevant standards or TL's approval document.

1.1 The post-weld heat treatment shall normally consist of stress relief heat treatment.

1.2 Components fabricated from steels which have undergone normalizing heat treatment shall be subjected to normalizing heat treatment if:

- The required characteristics of the welded joint can only be established by normalizing heat treatment

or

- The component has undergone hot-forming after welding, unless hot-forming was completed within a temperature range equivalent to normalizing heat treatment.

**1.3** Components fabricated from quenched and tempered steels shall be subjected to quenching and tempering if:

- The required characteristics of the welded joint can only be achieved by quenching and tempering

or

- The component has undergone hot-forming after welding.

If, in the case of air-hardened and tempered steels, the hotforming of the component was on the whole performed under the conditions applicable to normalizing heat treatment, tempering alone is sufficient.

**1.4** For such welded joints, preheating and treatment by quenching and tempering or by tempering alone should as a rule be carried out in accordance with the instructions of the material or consumable manufacturer. A special means of heat treatment shall be specified if, for instance, the material or the weld metal is hardened to an unacceptable degree during welding.

For high-alloy steels with a ferritic or austenitic structure, the need for and method of heat treatment shall be determined on an individual basis.

**2.** Post-weld heat treatment may be dispensed with if the following conditions are met:

**2.1** Prior to welding, the materials must be in the heat-treated condition specified in the relevant standards or in the TL's approval document. This condition is also deemed to be met if the required heat-treated condition is only attained during subsequent fabrication.

**2.2** The nominal wall thickness at the joints may not exceed 30 mm.

**2.3** In the chemical composition (melt analysis) of the base material and the weld metal, the following contents may not be exceeded:

- C 0,22 %, Si 0,50 %, Mn 1,40 %, Cr 0,30 %, Cu 0,30 %, Mo 0,50 %, Ni 0,30 %, V 0,20 %,
  -

In this context, the following conditions shall also be satisfied:

- $Cr + Ni \leq 0,30 \%$  und  $Mn + Mo + V \leq 1,6 \%$ .

These conditions may be relaxed in the case of steels which have been rendered resistant to brittle fracture and hardening by special metallurgical measures. Their suitability and properties shall be demonstrated to the TL after an adequate period of proving. The steels' resistance to brittle fracture, resistance to hardening and weldability must be equivalent to those of steels falling within the above analytical limits. For the weld metal, at a C content  $\leq 0,10 \%$  the Si content shall be  $\leq 0,75 \%$ , the Mn content  $\leq 2,0 \%$  and the sum of the Mn, Mo and V contents  $\leq 2,5 \%$  if welding consumables are used which produce a weld metal with a particularly high toughness, e.g. by using welding consumables with basic characteristics.

**3.** Post-weld heat treatment may be dispensed with for butt welds located in the flue gas stream in tubes made of 13CrMo44 steel with no lower limit for the average wall temperature and in pipes made of 10CrMo9 10 steel above an average wall temperature of approx. 490 °C, provided that the outside tube diameter does not exceed 63,5 mm and the wall thickness does not exceed 10 mm. Butt welds between the tubes and tube nipples are included under this provision, even if they are not located in the flue gas stream.

Table 13.2 Requirements applicable to the mechanical and technological tests

Type of test	Requirements		
Tensile test transversely to weld	As stipulated for the base material or in the test of product suitability for the welding consumable.		
Hot tensile test on a specimen taken from the weld metal	As stipulated for the base material or in the test of product suitability for the welding consumable.		
Notched bar impact test (1) on specimen from centre of weld	As stipulated for the base material in transverse direction. For welded joints in austenitic steels, $\geq 40$ J with ISO-V-notch specimens. The test shall be performed at room temperature.		
Technological bend test	<b>Bending angle</b>	<b>Strength category (2)</b>	<b>Mandrel diameter</b>
	180° (3)	Ferritic steels with a minimum tensile strength $< 430$ N/mm <sup>2</sup>	2 × a
		Minimum tensile strength $\geq 430$ N/mm <sup>2</sup> to 460 N/mm <sup>2</sup>	2,5 × a
	180° (3)	High-temperature austenitic steels Ferritic steels with a minimum tensile strength $\geq 460$ N/mm <sup>2</sup>	3 × a
	If a bending angle of 180° is not attained, the following applies:		
	$\geq 90^\circ$	Elongation ( $L_0$ = width of weld + thickness, symmetrical to weld) $\geq$ minimum elongation $A_5$ of base material.	
or $< 90^\circ$	Elongation over width of weld $> 30\%$ (4) and faultless appearance of fracture.		
Metallographic examination	The macrographic specimen of the welded joint must reveal a satisfactory weld build-up and full penetration of the weld. The micrographic section is to be examined for cracks. Cracks are not acceptable. In the case of welded joints in austenitic steels, hot cracks are acceptable provided that they are few in number and widely scattered.		
Hardness testing	The hardness in the heat-affected zones shall not exceed 350 HV 10. Hardness peaks in excess of this figure in narrow transition zones shall not give rise to complaints if the outcome of the technological tests meets the requirements.		
<p>(1) For specimens less than the standard 10 mm in width, the impact energy requirements decrease in proportion to the cross section of the specimen.</p> <p>(2) The tensile strength applies to the area of least thickness.</p> <p>(3) The 180° requirement is deemed to have been met if the bend test was performed according to ISO 5173 and pressure was applied by the supports without cracks appearing.</p> <p>(4) Different values may be agreed on for steels not welded with matching filler.</p>			

4. Components shall generally be heat-treated in their entirety. In the case of stress relief heat treatment and tempering heat treatment, an exception from sentence 1 may be made if

- In the case of cylindrical components, a sufficiently wide cylindrical section or
- In the case of longitudinal welds in open shell rings without a circumferential weld, the weld zone over a sufficient width

is heat-treated by (continuous) uniform heating, on both sides if possible, provided that TL's expert raises no objection. In both cases, thermal stresses must not be allowed to shift to parts subject to flexural stresses (e.g. flanges or cut-outs).

5. Welding of small parts into and onto the walls of steam boilers shall generally be carried out prior to heat treatment. This especially applies if:

- The nominal wall thickness of the basic structure exceeds 30 mm (see para. 2.2),
- The contents specified in para. 2.3 are exceeded,
- Cold forming takes place in conjunction with welding.

When welding in individual small parts, heat treatment may be dispensed with if the properties of the materials to be joined and the welding process enable the making of a satisfactory welded joint which is appropriate to the conditions of service and the working temperature.

6. Documentary proof of the heat treatments described in items 1.1 to 1.4 shall be provided by means of a works certificate to EN 10204 or ISO 10474, as applicable, which shall state the method, temperature and duration of the heat treatment and the method of cooling. Any special heat treatment, e.g. temporary cooling after welding prior to tempering treatment, shall be recorded in the works certificate.

## I. Inspection of Welded Components

1. Where no production tests are carried out on welded shell rings which have undergone hot bending or heat treatment, for materials with a minimum tensile strength  $\geq 440 \text{ N/mm}^2$  **(2)** and alloy steels **(1)** a test piece taken from the plate used and stamped by TL's expert shall be subjected to the same treatment as the shell ring. A tensile test and a notched bar impact test (three test specimens) shall be performed on specimens from this test piece to establish the ultimate condition of the material of the drum or the shell ring.

2. Fully welded drums for water-tube boilers with upset or prewelded ends shall be subjected to the tests specified in para. 2.1 to 2.4.

2.1 The drums shall be subjected by TL's expert to a hydraulic pressure test at 1,5 times the working pressure, subject to the limitation that the resulting stress shall not exceed 0,9 times the yield strength at 20 °C, taking into account the positive diameter tolerance and the negative wall thickness tolerance. The component shall exhibit no leaks during the hydraulic pressure test and no permanent deformation afterwards. This test may be dispensed with if the complete longitudinal and circumferential welds have been subjected to non-destructive testing by appropriate means with satisfactory results.

2.2 Where dished drums are fabricated from steel with a minimum tensile strength  $\geq 440 \text{ N/mm}^2$  **(2)** and a minimum yield strength at room temperature  $\geq 320 \text{ N/mm}^2$  and the nominal wall thickness is greater than 30 mm, following the final heat treatment three core samples shall be drilled out of the metal, one being taken from each end of the cylindrical part and one from the middle of the drum. The exact location of the sampling points, which shall be offset relative to each other by approx. 120° if possible, shall be indicated to the drum manufacturer by the steam boiler manufacturer in good time.

---

**(2)** *The threshold may be raised to 470 N/mm<sup>2</sup> if proof is furnished that stress relief heat treatment is not liable to result in an unacceptable reduction in the yield stress.*

The core sample shall be at least 60 mm in diameter to enable one specimen for tensile testing and one set of three specimens for notched bar impact testing to be prepared. The specimens shall be cut out transversely to the direction of rolling of the plate; if possible, the tensile test specimen should be located 1/6 of the wall thickness below the surface. Of the three notched bar impact test specimens, one shall be taken from each of the extremities and one from the middle of the core sample.

**2.3** Where cold-bent shell rings with a degree of deformation > 5 %, hot-bent shell rings or dished half-drums are fabricated from steel with a minimum tensile strength  $\geq 440 \text{ N/mm}^2$  (2) and a minimum yield strength at room temperature  $\geq 320 \text{ N/mm}^2$  and the nominal wall thickness is greater than 30 mm, following heat treatment a sufficiently wide ring shall be cut off, from which one specimen for tensile testing and one set of three specimens for notched bar impact testing shall be taken transversely to the direction of rolling of the plate. Alternatively, the procedure described in 2.2 may be followed.

**2.4** If, in the situations described in items 2.2 and 2.3, the final heat treatment consists solely of stress relief heat treatment or if working is carried out only within the stress relief heat treatment range and is not liable to change the properties of the material substantially, the specimens prescribed in items 2.2 and 2.3 may be prepared beforehand and heat-treated in the same manner. In this case, the temperature of the specimens over their length and the extent of the variation in temperature shall be measured and recorded.

**3.** The requirements applicable to the mechanical and technological tests stated in items 1. and 2. are governed by the provisions Chapter 2, Materials. Section 3, D and Section 4, F.

In testing of the base material after heat treatment, a negative tolerance of 5 % applies in individual cases to the minimum yield strength and the minimum tensile strength if a load in the area of the high temperature yield strength is applied.

The yield strength and tensile strength may be less than the minimum by more than 5 %, up to 10 %, if proof is furnished that

- Heat treatment has been satisfactorily carried out,
- The requirements applicable to the elongation of the base material are met,
- The requirements applicable to the impact energy of the base material are met,
- The dimensional design based on the high-temperature yield strength established is still adequate.

Where loads in the area of the creep strength are applied, the yield strength and the tensile strength may be less than the specified minimum by max. 10 %.

**4.** An internal and external inspection shall be carried out on the completed shell rings and drums, and especially of the welds and adjacent areas and the dished ends. For the inspection, the components shall have a smooth external and internal surface corresponding to the condition as manufactured, to ensure that significant surface defects can also be detected; the internal surface is to be descaled. At the same time, measurements shall be carried out to determine:

#### **4.1 External circumference**

The measurements shall be spaced at approximately 1 m intervals over the entire length of the component. The measurements of the external circumference shall be used to determine the average outside diameter. The outside diameter of the shell rings and drums may not vary from the stipulated outside diameter by more than  $\pm 1,0 \%$ .

#### **4.2 Out-of-roundness**

The measurements shall be spaced at approximately 1 m intervals over the entire length of the component.

The out-of-roundness

$$U = \frac{2 \cdot (D_{\max} - D_{\min})}{D_{\max} + D_{\min}} \cdot 100\%$$



of the drums and shell rings following final heat treatment shall be:

- For non-heat-treated or stress relief heat-treated drums and shell rings where the wall thickness is > 1 % of the nominal diameter: 1 % max.
- For normalizing heat-treated, quenched and tempered or dished drums: 2 % max.

In calculating the out-of-roundness, the elastic deformations arising from the component's own weight shall be discounted. Isolated bulges and dents must also lie within the tolerances. In addition, the bulges and dents must have a flat profile and their depth, measured as a deviation from the normal roundness or from the shell line, as applicable, must not exceed 1 % of the length or width of the dent or bulge.

The out-of-roundness need not be determined where the wall thickness is < 1 % of the nominal diameter.

#### 4.3 Camber or flattening

The degree of camber or flattening in the area of the longitudinal welds, measured as a deviation from the normal roundness with a template length of 500 mm, may not exceed the dimension "a".

Depending on the ratio of the average diameter  $d_m$  to the wall thickness  $s_e$  of the drum or shell ring, the following applies:

- $a \leq 10$  mm for shell rings:  $\frac{d_m}{s_e} < 40$
- $a \leq 5$  mm for shell rings:  $\frac{d_m}{s_e} \geq 40$

#### 4.4 Axial non-linearity

The degree of axial non-linearity may be:

- For shell rings: up to 0,3 % of the cylindrical length

- For drums: up to 0,5 % of the cylindrical length

#### 4.5 Wall thickness of welds and adjoining plate areas

The wall thickness in the plate must lie within the tolerance permitted for the plate.

5. If special conditions of fabrication apply to the components stated in items 1 and 2, i.e. where large wall thicknesses or difficult-to-weld steels are used, non-destructive testing of the welds may also be necessary for an evaluation of up to  $V = 0,8$ . Welded joints in steels which, according to the report of the TL's expert, are subject to a non-standard method of heat treatment shall undergo the tests stipulated in the report, especially hardness testing and ultrasonic inspection. Proof of the outcome of these tests shall be provided by acceptance test certificate A or B to EN 10204 or ISO 10474, as applicable in accordance with TL's report.

6. An acceptance test certificate A to EN 10204 or ISO 10474, as applicable showing that the requirements stated in items 3. and 4. are met shall be furnished where one of the following limits is exceeded:

- Overall length of cylindrical shell ring in excess of 2500 mm,
- Specified external diameter in excess of 1200 mm,
- Acceptable working pressure in excess of 16 bar,
- Weld factor higher than  $V = 0,8$ .

Below these limits, an acceptance test certificate B to EN 10204 or ISO 10474, as applicable is sufficient.

7. An internal and external inspection of the completed smooth or corrugated furnaces, and especially of the welds and adjoining areas, shall be carried out. During the inspection the following shall be measured:

### 7.1 Deviation from specified external circumference

The measurements shall be spaced at approx. 1 m intervals over the entire length of the components. The permitted deviations from the external circumference specified in the order in a measurement cross section are:

For corrugated furnaces	
non-corrugated portion:	±15mm
corrugated portion pull-through type:	+0 mm -75 mm
other corrugated tubes:	+15 mm -60 mm
For smooth furnaces	
at the ends of shell rings over a distance of 250 mm	±15mm
in the remainder of the cylindrical shell rings:	+0 mm -75 mm
For smooth furnaces with flanged ends	
cylindrical portion	+0 mm -75 mm

### 7.2 For corrugated tubes, difference between maximum outside diameter and associated inside diameter

The measurements shall be spaced at approx. 1 m intervals over the entire length of the components. For corrugated tubes, the difference between the maximum outside diameter and the inside diameter in the corrugations shall equal the specified dimension with a maximum negative tolerance of 20 mm.

### 7.3 Out-of-roundness

The measurements shall be spaced at approx. 1 m intervals over the entire length of the components. The wall thickness shall invariably be measured at the ends of the shell rings and at any point where a decrease in wall thickness is significant.

The out-of-roundness

$$U = \frac{2 \cdot (D_{\max} - D_{\min})}{D_{\max} + D_{\min}} \cdot 100\%$$

shall not exceed:

- For corrugated furnaces: 1,0 %
- For smooth furnaces: 1,5 % up to a maximum of 15 mm.

### 7.4 Non-linearity

The non-linearity shall be measured by placing a length of cord against the wall. It may not exceed 0,3 % of the cylindrical length of the shell rings.

### 7.5 Wall thickness of welds and adjoining plate areas

The following tolerances apply to the wall thickness of corrugated tubes: the average wall thickness must at least equal the nominal wall thickness within the corrugation pitch. Localized deficiencies of up to 10 % in the wall thickness within the corrugation pitch are permitted. The reduction in wall thickness is to be compensated for when manufacturing the corrugated tubes by means of an appropriate increase in the wall thickness of the original tube. The area A calculated from the specified corrugation depth and the specified wall thickness must be attained. With a corrugation depth w of 75 mm, a deficiency of 5 % in the area A is acceptable. In the flanged portion, a deficiency of up to 20 % in the wall thickness is permitted. In the assessment, defects which in the opinion of TL's expert are clearly unimportant with regard to safety shall be disregarded. Smooth furnaces are subject to the tolerances applicable to plates.

8. Proof that the requirements stipulated in 7. are met shall be furnished by means of an acceptance test certificate A to EN 10204 or ISO 10474, as applicable. A hydraulic pressure test is not required for furnaces.

9. The cut-out areas of headers certified

according to quality grade I under EN 10216-2 (see Chapter 2, Materials, Section 4, C) shall be subjected to appropriate non-destructive testing by the boiler manufacturer and the outcome of the testing shall be certified.

## 10. Repair Welds

Exceptions to the foregoing rules may be made for repair welds in justified special cases, provided that TL's expert is informed of the nature and scope of the planned welds before work commences and he has no objections to the planned exceptions.

## 11. Production Test

The production test comprises non-destructive testing of the component and quality inspection of test pieces (mechanical and technological tests).

### 11.1 Non-destructive testing

All longitudinal and circumferential welds shall be subjected to non-destructive testing over their entire length. They shall also be examined for surface cracks if necessary. The tests shall be performed in accordance with Section 10.

For circumferential welds where the wall thickness is < 30 mm, testing of 25 % of the length of the weld is sufficient; however, all junctions with longitudinal welds shall be tested.

The tests shall not be performed until the final heat treatment of the component has been carried out.

The non-destructive tests shall not reveal any major defects in the weld. Such defects include cracks, lack of sidewall fusion and, in single-side welds, insufficient root penetration. Other defects such as pores and slag shall be assessed in accordance with recognized codes, e.g. AD code HP 5/3 or the ASME Boiler and Pressure Vessel Code, Section I.

The results of the non-destructive tests shall be documented and presented to the TL's expert for assessment at the time of the structural inspection.

## 11.2 Quality testing of test pieces

The following tests shall be carried out on a test piece welded at the same time as the component as an extension of a longitudinal seam (see items 11.3.6 and 11.4):

- Tensile test on two specimens, shape of specimen according to EN ISO 4136; however, test length = width of weld + at least 80 mm.
- Technological bend test to EN ISO 5173 on four transverse bending test specimens (two specimens each with opposite sides of the weld in tension). On the side in tension, after machining off the weld reinforcement the original surface of the test piece shall be preserved to the greatest possible extent. Sizeable depressions such as undercuts and root notches shall not be repaired.
- Notched bar impact test on ISO V-notch specimens to EN ISO 9016 (EN ISO 148-2) on three specimens taken from the centre of the weld metal with the position of the notch vertical to the surface of the test piece.

The test temperature and requirements are shown in Table 13.2.

- Structure examination of a specimen (macro-graphic specimen); for alloy 1 steels, a micro-graphic specimen is also required.
- A radiographic inspection to ISO 17636 shall be carried out prior to sectioning of the test piece.

Also, if the working temperature exceeds 350 °C:

- Tensile test to EN ISO 5178 (EN ISO 6892-1) on a specimen from the weld metal (cylindrical specimen with  $L_0 = 5d$  to DIN 50125) for thicknesses  $\geq 20$  mm to determine the 0,2 % proof stress at the working temperature

or

- Analysis of the weld metal with regard to the constituents which determine the mechanical properties at elevated temperature

as decided by TL's expert.

For materials with a minimum tensile strength of  $\geq 440 \text{ N/mm}^2$  and alloy 1 steels subjected to post-weld heat treatment, a tensile test and a notched bar impact test on specimens taken from the base material transversely to the direction of rolling shall also be performed on the test piece.

### 11.3 Number, removal and dimensions of the test pieces for quality testing

#### 11.3.1 Procedure for the first six shell rings

If the higher evaluation is being made use of for the first time or is being extended through the inclusion of new types or grades of material, a test piece located at one end of each of the first six shell rings shall be welded together with the shell ring and tested. Unless otherwise stipulated, the specimens stated in 11.4 shall be taken from this test piece. The test pieces required for these production tests shall be taken from the plates to be used for the component. Every melt shall be covered.

#### 11.3.2 Procedure from the seventh shell ring onwards

The preparation and number of test pieces depends on whether or not post-weld heat treatment is necessary; see H.2.

11.3.3 For components where heat treatment is unnecessary, the following applies, provided that the analytical limits stated in H.2.3. are not exceeded:

#### - Preparation:

The test pieces may be taken from plates of the same type and strength category and approximately the same thickness as those used for the shell ring; a difference of  $\pm 5 \text{ mm}$  is acceptable. The characteristics of the plates must be verified in accordance with Chapter 2,

Material, Section 3, 4, 5, 6 and 7).

#### - Number of test pieces:

One test piece shall be welded as an extension of one of the longitudinal seams of each component, irrespective of the number of shell rings.

11.3.4 For components where heat treatment is necessary, the following applies:

#### - Preparation:

The test pieces shall be taken from plates to be used for the component in question.

#### - Number of test pieces:

One test piece shall be welded as an extension of one of the longitudinal seams of each component, irrespective of the number of shell rings. If the component consists of material from several melts, one test piece shall be welded for each melt. If the analytical values differ only slightly, TL's expert may reduce the number of test pieces accordingly, even if a component consists of material from several melts.

11.3.5 The number and locations of the test pieces are shown in Table 13.3.

After at least 50 production tests per material category, relaxations may be agreed with TL.

#### 11.3.6 Size of test pieces

The size of each test piece shall be such that the specimens prescribed in 11.4.2 and a sufficient number of retest specimens can be taken from it.

### 11.4 Welding of test pieces, number and removal of test specimens

#### 11.4.1 Welding of test pieces

The seam of the test piece shall be welded in the

course of fabrication together with the last 300 mm of weld of the shell ring. TL's expert has the right to be present while this weld is made. The test pieces shall undergo a heat treatment which is demonstrably similar to that applied to the component.

#### 11.4.2 Number of test specimens

From every welded test piece, specimens for the tests prescribed in 11.2 shall be stamped by TL's expert and removed. The specimens shall alternate with each other and lie adjacent to each other.

The remainder of the test piece is intended for retests. It shall also be stamped and marked in such a way that its affiliation can be unequivocally established.

### 11.5 Requirements

#### 11.5.1 Mechanical and technological tests

The mechanical and technological tests are governed by Table 13.2 in conjunction with I.3.

#### 11.5.2 Retest specimens

If one of the tests listed in 11.2 fails to achieve the required result, each unsuccessful test shall be repeated by testing two more specimens of the same type taken from the remainder of the test piece. The test conditions are met if the retest specimens meet the requirements.

#### 11.6 Supplementary tests

Further tests, e.g. notched bar impact tests with the fracture section in the transition zone or radiographic inspections in various directions, shall be performed if considered necessary by the competent expert in special cases for assessment of the weld.

**Table 13.3 Number and locations of test pieces**

	Heat treatment	
	unnecessary	necessary
1st to 6th shell ring	One test piece per shell ring taken from the plates to be used for the component. Every melt is to be covered (see I.11.3.1)	
From 7th shell ring and further components consisting of on shell ring	One test piece per shell ring (see I.11.3.2)	
two or more shell rings	One test piece per component taken from plates of the same strength category and approx. the same thickness (difference of $\pm 5$ mm are acceptable).	One test piece per component; where different melts are used however, one test piece for each melt from one of the plates to be used for the components.
After at least 50 production tests per material group	Relaxations by agreement with TL (see TRD 201, Appendix 3, item 6)	

## SECTION 14

### WELDING OF PRESSURE VESSELS

	Page
<b>A. GENERAL</b> .....	14- 2
1. Scope	
2. Other Relevant Rules	
3. Assessment of Welds	
<b>B. APPROVAL OF WELDING SHOPS, WELDING PERSONNEL</b> .....	14- 3
<b>C. QUALITY INSPECTION, RESPONSIBILITY</b> .....	14- 3
<b>D. MATERIALS, WELDABILITY</b> .....	14- 4
<b>E. WELDING CONSUMABLES AND AUXILIARY MATERIALS</b> .....	14- 4
<b>F. WELDING PROCEDURE TESTS</b> .....	14- 5
1. General	
2. Welding of Test Pieces, Welding Procedure Specification (WPS)	
3. Test Principles, Delimitation of Scope	
4. Tests, Scope of Tests	
5. Test Requirements	
6. Storage of Specimens	
7. Validity, Extension of Welding Procedure Tests	
<b>G. WELDING TECHNIQUE</b> .....	14-10
<b>H. POST-WELD HEAT TREATMENT</b> .....	14-11
<b>I. INSPECTION OF WELDED COMPONENTS</b> .....	14-12

**Preliminary remark:**

The following rules relating to the welding of pressure vessels comply with or incorporate the AD codes of practice. Subject to the approval of TL, other codes of practice such as the ASME Boiler and Pressure Vessel Code, Section VIII may also be adopted for the fabrication and testing of welded pressure vessels (the following rules being applicable in analogous manner). See also Section 1, B.1.4.

**A. General****1. Scope**

**1.1** These Rules apply to the fabrication and testing of the following welded steel tanks, vessels and process equipment which are designed to withstand an internal working pressure:

**1.1.1** Tanks, vessels and process equipment fabricated from unalloyed and alloyed ferritic steels with nominal yield strengths up to 380 N/mm<sup>2</sup>.

**1.1.2** Tanks, vessels and process equipment fabricated from austenitic stainless steels.

**1.1.3** Cargo tanks **(1)** and process vessels fabricated from steels tough at subzero temperatures for the carriage of cooled liquefied gases.

**1.2** Tanks, vessels and process equipment fabricated from other materials not mentioned in 1.1 may be manufactured and tested in accordance with technical codes recognized by TL. Examples of recognized technical codes are the more comprehensive requirements set out in the AD Codes of Series HP published by the "Arbeitsgemeinschaft für Druckbehälter" (Pressure Vessel Manufacturing Association).

**1.3** The design and testing of tanks, vessels and process equipment joined by other processes

(e.g. brazed or bonded) shall be subject to agreement between the manufacturer and TL's head office in each individual case (See also, Section 1, A.1.1).

**2. Other Relevant Rules**

**2.1** The provisions of the Chapter 4, Machinery Installations, Section 14 shall also be complied with in the design and dimensioning of pressure vessels and process equipment.

**2.2** Cargo tanks designed to carry chemicals are also subject to the provisions of the Chapter 8, Chemical Tankers, Section 1.

**2.3** Cargo tanks and process vessels designed to carry cooled liquefied gases are also subject to the provisions of the Chapter 10, Liquefied Gas Tankers.

**3. Assessment of Welds**

**3.1** Tensionally stressed longitudinal welds in pressure vessels and process equipment, except for such welds in cargo tanks for carriage of liquefied gases, may generally be evaluated according to a weld factor up to  $v = 0,85$ , provided that they meet the requirements specified in Section 1 and 2, and in D, E, G and H.

A higher evaluation up to  $v = 1,0$  may be applied if a production test and non-destructive testing in accordance with I.4. have been successfully performed on the finished component.

**3.2** Cargo tanks for liquefied gases shall be so constructed that their longitudinal welds can be evaluated according to a weld factor of at least  $v = 0,95$ . A further condition is successful performance of the production tests and non-destructive tests specified in I.4.

A higher evaluation up to  $v = 1,0$  may be applied if the characteristics of the material, the type of the welded joints, the welding process and the type of loading so permit and TL has approved the higher evaluation.

**(1)** Independent "Type C" tanks.

## B. Approval of Welding Shops, Welding Personnel

1. All welding shops intending to perform welding work within the scope of these rules must satisfy the requirements applicable to welding shops and personnel set out in Section 2 and must have been approved by **TL**. Applications for approval shall be submitted by the welding shops in good time before starting the welding work, enclosing the information and documentation prescribed in, Section 2, A.3.

2. The welding personnel (welders and welding supervisors) and, where applicable, inspectors and inspection supervisors must satisfy the requirements set out in, Section 2, B.2., B.3. and B.4. and be recognized by **TL**. For the welder's qualification tests, see Section 3.

## C. Quality Inspection, Responsibility

1. The manufacturer shall submit to **TL**, for inspection, drawings and other relevant documents containing at least the following information:

- The materials and welding consumables to be used,
- The welding process and the location and shape of the weld,
- The type of heat treatment, if required,
- The acceptable working pressure,
- The calculated temperature or, in the case of vessels fabricated from steels tough at sub-zero temperatures, the minimum design temperature,
- The operating temperature,
- The test pressure,
- The weld factor used as a basis for calculation,

– The nature and scope of the non-destructive tests,

– The nature and scope of the production tests.

2. If the quality or good working order of a component cannot be guaranteed or is in doubt due to inadequate or missing information in the manufacturing documents (e.g. production drawings), **TL** may demand appropriate improvements.

3. The welding shops shall ensure by means of regular in-house quality inspections during fabrication and on completion of the welding work that this work has been performed competently and satisfactorily (See Section 1, F.). For the duties and responsibilities of the welding supervisor, see also ISO 14731.

4. The welding shops are responsible for ensuring that the welding work conforms to these Rules, the approved manufacturing documents, any conditions stipulated in the approval documents and the latest state of welding practice. The inspections and checks to be performed by **TL**'s Surveyor do not relieve the welding shops of this responsibility.

5. With regard to quality inspections and the responsibilities involved in awarding subcontracts to independent branches or suppliers or to approved or non-approved outside firms working in the welding shop (subcontractors), see Section 1, F. Subcontracting of work or employment of temporary workers shall be notified to **TL**.

6. The scope of the required quality inspections depends on the construction project in question. It is essential to ensure, however, that the intended materials, welding consumables and auxiliary materials are used and that the weld preparation, assembly, execution of the tack and final welds and the dimensional accuracy and completeness of the welded joints meets the requirements stated in 3. For non-destructive testing of the welded joints and production tests have to be performed, see I.

7. Following internal inspection and, if neces-



sary, repair by the welding shop, the components shall be presented to TL's Surveyor for checking at suitable stages of fabrication. For this purpose they shall be readily accessible and shall normally be uncoated. Where the previous inspection has been inadequate, the Surveyor may reject components and require that they be presented again after satisfactory workshop inspection and any necessary repair work has been performed.

8. TL is not responsible for guaranteeing that all the components and welded joints inspected to the prescribed extent (generally on a random basis) by its surveyors have been fabricated in accordance with the conditions and meet the requirements in every respect. Components or welded joints which subsequently turn out to be defective may be rejected or their repair may be demanded even if acceptance testing has already been carried out.

#### D. Materials, Weldability

1. The materials selected must be appropriate for the intended purpose, with allowance made for mechanical and thermal stresses. The characteristics of materials subjected to further processing shall be such that they are able to withstand the operating loads.

2. Welded structures may only be fabricated using base materials of proven weldability. The intended materials must comply with the requirements set out in the relevant sections. Chapter 2, Materials. Other comparable materials may only be used after TL has given its approval in each individual case.

3. Materials for cargo tanks and process vessels for liquefied gases must also meet the impact energy requirements at the stipulated test temperature; See Table 14.3.

#### E. Welding Consumables and Auxiliary Materials

1. The welding consumables and auxiliary materials must enable a welded joint to be made

which is appropriate to the base material, the operating temperature and the conditions of service. The suitability of the welding consumables must also have been verified under the conditions prevailing in further processing and heat treatment.

2. All the welding consumables and auxiliary materials used (e.g. covered electrodes, wire-gas combinations, wire-flux combinations, etc.) must have been approved by TL in accordance with Section 5. They may also, however, be approved if tested at the same time as the welding procedure and restricted to the user's works (see Section 4, B.3.2 and Section 5, A.1.4).

3. Welding consumables for steels tough at subzero temperatures must also meet the impact energy requirements for the weld metal at the stipulated test temperatures; see Table 14.3.

4. If it is necessary, in special cases, to use welding consumables of dissimilar material where the strength of the resulting weld metal is lower than that of the base materials, e.g. when welding 9 % nickel steel with austenitic consumables, appropriate allowance shall be made in the design calculations for the vessels.

5. Welding consumables and auxiliary materials specified in a procedure approval document with a maker's or brand name (see F.3.5) may only be replaced by equivalent consumables approved by TL with an appropriate quality grade if this is explicitly stated in the respective approval document. Failing this, TL's agreement shall be obtained.

6. The welding consumables and auxiliary materials may only be used in the approved welding positions. The manufacturers' recommendations and instructions for welding (e.g. type of current and polarity) shall be followed.

7. The welding consumables and auxiliary materials (especially hydrogen-controlled, basic-covered electrodes and basic welding fluxes) shall be re-dried before use in accordance with the manufacturer's instructions (observe maximum drying time!) and stored in a dry place (in heated containers or the like) at the workplace.

## F. Welding procedure tests

### *Preliminary remark:*

*In contrast to earlier issues of these Rules, welding procedure tests shall be performed in accordance with EN ISO 15607-EN ISO 15614, as applicable. This paragraph essentially covers requirements applicable to the welding of pressure vessels over and above those set out in EN ISO 15614-1.*

### 1. General

Only those welding procedures shall be employed whose satisfactory operational handling and adequate quality properties have been verified as part of a welding procedure test under production conditions at the user's works. The general requirements set out in Section 4, shall be observed. The welding procedures must have been approved by TL for the particular welding shop in question.

### 2. Welding of Test Pieces, Welding Procedure Specification (WPS)

**2.1** A preliminary "manufacturer's" welding procedure specification (pWPS) setting out all the major parameters shall be produced by the welding shop for the welding of test pieces in accordance with EN ISO 15609-1, as applicable.

**2.2** TL's expert shall select one of the welders whose names are to be supplied by the manufacturer to weld the test pieces.

**2.3** The test pieces shall be made from materials whose properties are proven in accordance with the requirements specified in Chapter 2, Material, Section 3, 4, 5, 6, 7. Pre-treatment and after-treatment of the test pieces by preheating, heat treatment and the like is only permitted if stipulated for these materials during actual fabrication.

**2.4** The types of weld and welding positions employed in the fabrication process shall be qualified in the welding procedure test.

**2.5** The shape and dimensions of the test pieces are specified in EN ISO 15614-1 or, where applicable, stipulated in 2.6 and 2.7.

**2.6** The plate test pieces for cargo tanks designed to carry liquefied gases shall be executed as shown in Fig. 14.1.

**2.7** For making fillet welds on tanks for the carriage of liquefied gases, the following shall be made:

- One fillet-welded test piece approx. 300 mm long for each welding position (see Fig. 14.2)
- One Y test piece approximately 300 mm long from the joint between the central longitudinal bulkhead and the tank walls for each welding position (see Fig. 14.3) (where applicable, e.g. for bilobe tanks).

### 3. Test Principles, Delimitation of Scope

The qualification of the welding procedure shall be ascertained in accordance with EN ISO 15607 by means of welding procedure qualification tests, for steel in accordance with EN ISO 15614-1.

The test is valid within the limits described in 3.1 to 3.7.

The scope of the welding procedure test is specified by TL in writing. Any exceptions require the performance of a supplementary test, the scope of which shall be decided by TL. Production tests may be recognized as supplementary tests.

#### 3.1 Material groups

Above and beyond the grouping system of EN ISO 15614-1, the following provisions shall be observed:

- For materials which have to satisfy particular corrosion conditions (e.g. resistance to caustic cracking) the welding procedure tests shall be geared to these.
- A welding procedure qualification performed on group 1 killed steel does not apply to unkilld steels unless they were welded using basic covered electrodes or wire-flux combinations with basic flux.

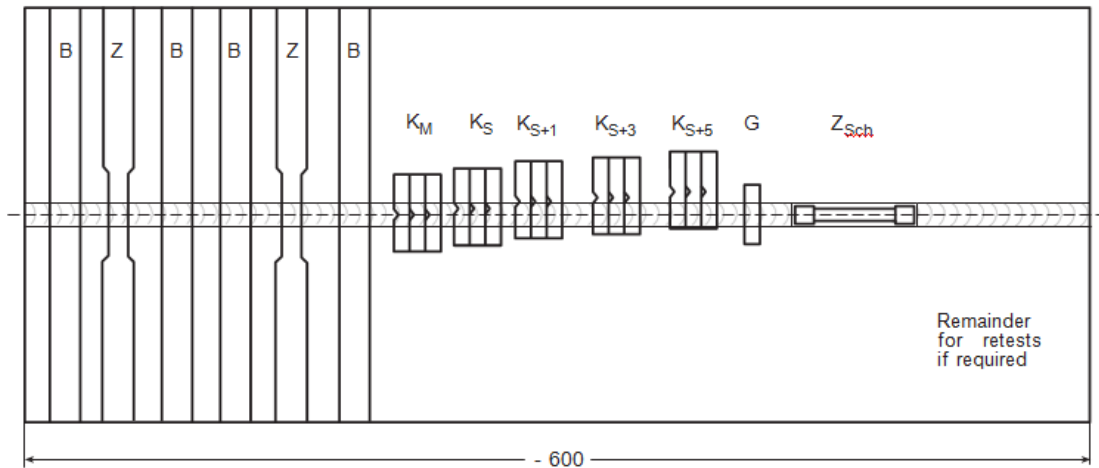

Fig. 14.1 Test piece for cargo tanks

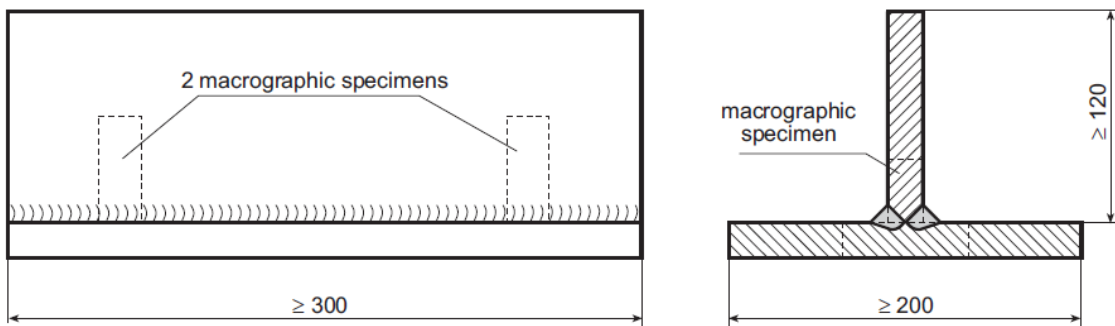

Fig. 14.2 Fillet-welded test piece

- Approval is also granted for the following further material combinations in addition to those stipulated in EN ISO 15614-1 but under the following conditions (see Table 14.1).
- Deviating from EN ISO 15614-1, a welding procedure test available for the combination group 9 welded to group 2 does not incorporate the combination group 9 welded to group 3.
- Depending on material composition and/or the type of post-weld treatment required, TL may also limit the scope to the base material used in the welding procedure test.
- For the materials used in the fabrication of cargo tanks and process vessels for liquefied gases, the test applies only to the grade of steel inspected.

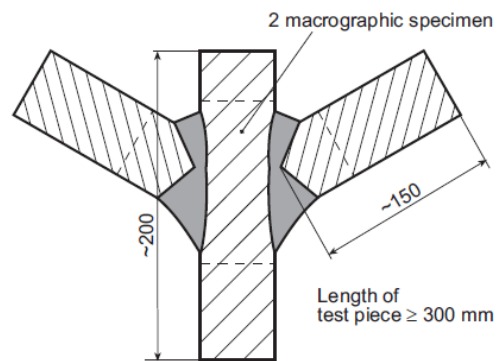

Fig. 14.3 Y test piece

**3.2 Welding process**

Recognition applies only to the welding process employed in the welding procedure test.

**3.3 Gas welding**

In gas welding a test performed on the wall thickness  $t$  shall apply to the wall thickness range  $0,75 t$  to  $1,25 t$ .

Table 14.1 Welding procedure qualification available for a steel group or combination joints

Welding procedure qualification available for a steel group or combination joints	Suitable for the following combination joints
5 (10CrMo9-10) welded with 4	4 welded with 5 (13CrMo4-5) 4 welded with 1 4 welded with 2 ( $R_e < 430 \text{ N/mm}^2$ )
5	5 welded with 1 5 welded with 2
6 welded with 4	6 welded with 5 6 welded with 2 6 welded with 1

### 3.4 Welding parameters

Welding procedure tests performed on multi-pass welds do not apply to single-pass welds.

### 3.5 Welding consumables and auxiliary materials

The requirements of EN ISO 15614-1 do not apply if the filler metal used is of the same type and has been approved by TL to be under the scope of the welding procedure qualification (see E.5.).

### 3.6 Heat treatment

The welding procedure test applies to the heat treated condition existing at the time of the test. Heat treatment of the test piece shall be performed so that a heat treated condition is achieved which is comparable to that of the component.

### 3.7 Special cases

For special cases, for example projection welds, welding of clad steels, stud welds and difficult repairs to be performed in the course of fabrication on steels which are susceptible to cracking due to hardening of the heat affected zone, welding procedure tests are necessary which are geared to these particular cases. The tests required and their scope are specified by TL in each individual case.

## 4. Tests, Scope of Tests

Testing comprises both non-destructive and destructive tests and shall be performed in accordance with EN ISO 15614-1.

Deviating from EN ISO 15614-1, the following specimens shall also be taken from the test pieces:

**4.1** One all-weld metal tensile test specimen with a diameter of 10 mm and  $L_0 = 5 d$  shall also be taken in the case of test pieces more than 20 mm thick in materials where the weld metal may be significantly affected by the welded joints.

This applies to steels in material groups 2 (high temperature steels only), 4 and 6. This test shall also be performed on group 7 materials where post-weld heat treatment is stipulated.

**4.2** Notched bar impact test specimens shall always be taken from the centre of the weld metal for each welding position in the case of wall thicknesses greater than 5 mm

**4.3** Notched bar impact test specimens shall also be taken from the weld boundary for each welding position in the case of material groups 2, 4, 5, 6, 7 and 9 (proportion of delta ferrite in the weld metal  $\leq 3 \%$ ) and wall thicknesses  $\geq 10 \text{ mm}$ .

**4.4** Micrographic specimen for alloy steels **(2)**. The structure shall be described and verified by means of photographs.

**4.5** Analysis of the weld metal for alloy steels **(2)**.

**4.6** Contrary to the provisions of 4.2 and 4.3, 3 notched bar impact test specimens with the notch perpendicular to the surface of the plate shall each be taken from the centre of the weld metal (KM), the weld boundary (fusion line KS) and also 1, 3 and 5 mm away from the fusion line in the heat affected zone ( $K_{S+1}$ ,  $K_{S+3}$ ,  $K_{S+5}$ ) for plate test pieces for cargo tanks for the carriage of liquefied gases; see Fig. 14.1.

## 5. Test Requirements

The irregularities in the test piece must fall within the limits specified for quality level B in accordance with ISO 5817, exceptions being: excessive weld reinforcement (butt and fillet welds), excessive root reinforcement and excessive throat thickness (fillet welds) which fall into quality level C.

For the mechanical and technological tests, Table 14.2 applies. The impact energy requirements for cargo tanks and process vessels designed to carry liquefied gases are given in Table 14.3.

## 6. Storage of Specimens

The tested specimens and the remaining portions of the test pieces shall be stored until the report on the welding procedure test has been issued (see also, Section 4, C.3.).

## 7. Validity, Extension of Welding Procedure Tests

The validity of a welding procedure test is generally 1 year provided that the preconditions under which it was granted have not significantly changed. It may be continued by means of regular production tests (see I.4.).

In addition to production tests and tests performed on welded components (see I.) non-destructive tests may, given certain preconditions, also be recognized by the TL for continuing the validity.

The welding procedure test shall be repeated if there is a break in the fabrication of pressure vessels or pressure vessel components lasting longer than one year.

## G. Welding Technique

1. Welds must exhibit full penetration over their entire cross section and must not have any cracks or lack of fusion defects. Wherever possible, the root shall be grooved and capped.

If backing rings are used when making circumferential welds, they must be removed after welding. This may be dispensed with in the case of small vessels, the inside of which is no longer accessible.

2. When welding plates of the same thickness, the edge misalignment shall not exceed the following values:

- Seams welded on both sides:

0,15 × plate thickness (mm), subject to a maximum of 3 mm

- Seams welded on one side only:

0,10 × plate thickness (mm), subject to a maximum of 2 mm.

For vessels fabricated from clad plates, a smaller edge misalignment tolerance may be necessary depending on the thickness of the cladding.

3. When welding plates whose thicknesses differ by more than 20 % or more than 3 mm, the thicker plate shall be bevelled to the thickness of the thinner plate at a maximum angle of 30°.

**(2)** For the classification of steels (unalloyed and alloyed), see EN 10020.

Table 14.2 Test requirements applicable to welded joints in steel

Type of test	Requirements		
Tensile test transversely to weld	Tensile strength as stipulated for the base material or in the assessment of suitability for the welding consumable		
Tensile test on a specimen of the weld metal	Yield strength or 0,2 % proof stress, tensile strength and elongation as stipulated for the base material or in the assessment of suitability for the welding consumable		
Notched bar impact test on ISO V-notch specimen taken from centre of weld	Where temperature of medium (1) is -10 °C or above: As stipulated for the base material in transverse direction. Test temperature as in testing of the base material, but not lower than -10 °C. When using ferritic-austenitic, austenitic and nickel-base welding consumables $\geq 40$ J		
	Where temperature of medium (1) is lower than -10 °C: At minimum working temperature, $\geq 27$ J (2) when using ferritic welding consumables, $\geq 32$ J (2) when using ferritic-austenitic, austenitic and nickel-base alloy welding		
Notched bar impact test on ISO V-notched specimen taken from weld transition zone	Where temperature of medium (1) is -10 °C or above: $\geq 27$ J (2); test temperature as in testing of the base material, but not lower than -10 °C		
	Where temperature of medium (1) is lower than -10 °C: $\geq 16$ J (2); at minimum working temperature		
Technological bend test	<b>Bending angle, Degrees</b>	<b>Strength category (3)</b>	<b>Bending mandrel dia.</b>
	180°(4)	Ferritic steels with: min. tensile strength $< 430$ N/mm <sup>2</sup> min. tensile strength $\geq 430$ to $460$ N/mm <sup>2</sup>	2 × a 2,5 × a
	180° (4)	Austenitic stainless steels and austenitic steels tough at subzero temperatures,	2 × a
		High-temperature austenitic steels, Ferritic steels, with a minimum tensile strength $\geq 460$ N/mm <sup>2</sup>	3 × a 3 × a
	or	If a bending angle of 180 degrees is not attained, the following applies: $\geq 90^\circ$   Elongation ( $L_{00}$ = width of weld + wall thickness, symmetrical to weld) $\geq$ minimum elongation A5 of base materials $< 90^\circ$   Elongation over width of weld $> 30$ % (5) and faultless appearance of fracture	
Metallographic examination	The macrographic specimen of the welded joint must reveal a satisfactory weld build-up and full penetration of the weld. The micrographic section is to be examined for cracks. Only hot cracks are acceptable, and then only if they are few in number and widely scattered and agreement has been reached with the Surveyor as to their acceptability with regard to the material and the range of application.		
Hardness testing	The hardness in the heat-affected zones shall not exceed 350 HV 10. Hardness peaks in excess of this figure in narrow transition zones shall not give rise to complaints if the outcome of the technological tests meets the requirements.		
(1) Cargo tanks and process vessels for liquefied gases are subject to the impact energy requirements at the relevant test temperatures as shown in Table 14.3.			
(2) Only one impact energy value may be lower than the minimum mean value, and only by max. 30 %.			
(3) The tensile strength value applies to the area of least thickness.			
(4) The 180-degree requirement is deemed to have been met if the bend test was performed according to ISO 5173 and pressure was applied by the supports without cracks appearing.			
(5) For steels welded with dissimilar consumables, e.g. X8Ni9, different values may be agreed with TL.			

Table 14.3 Impact energy requirements for cargo tanks and process vessels for liquefied gases

Type of steel	Minimum design temperature [°C]	Thickness t [mm]	Notched bar impact test on ISO V specimen	
			Test temperature	KV (J) min.
Carbon-manganese steels	0	t ≤ 20 20 < t ≤ 40	0 °C -20 °C	Centre of weld:  for ferritic consumables ≥ 27, for austenitic and nickel-base alloy consumables ≥ 32  Weld boundary and fusion line:  ≥ 27
Carbon-manganese steel incl. 0,5 % nickel steel	-55	t ≤ 25 25 < t ≤ 30 30 < t ≤ 35 35 < t ≤ 40	5 K below minimum design temperature (1), but not exceeding 10 K 15 K 20 K -20 °C	
Nickel alloy steels containing 1,5 % Nickel 2,25 % Nickel 3,5 % Nickel 5 % Nickel	-60 -65 -90 -105	t ≤ 25 25 < t ≤ 30 30 < t ≤ 35 35 < t ≤ 40	5 K below (-65 °C) 10 K minimum (-70 °C) 15 K design temperature (-95 °C) 20 K temperature (2) (-110 °C)	
Nickel alloy steels containing 5 % Nickel 9 % Nickel Austenitic steels	-165 (3) -165 -165	t ≤ 25 (4) t ≤ 25 (4) t ≤ 25 (4)	-196 °C -196 °C -196 °C	

(1) For components subjected to stress relief heat treatment after welding, a test temperature of 5 K below the minimum design temperature or -20 °C, whichever is lower, may be adequate.

(2) The test temperature shall not exceed the figures stated in brackets.

(3) The steel type 5 Ni may only be used for design temperatures down to -165 °C after a special test of product suitability.

(4) For thicknesses > 25 mm, the requirements shall be agreed with TL.

4. In the case of shells consisting of several rings, the longitudinal seams shall be staggered. As a guide, the amount of stagger should be 4 times the plate thickness, but at least 100 mm.

5. Lapped joints with fillet welds between shell rings, bottoms and tubes are only acceptable in individual cases as circumferential welds with a wall thickness of 8 mm, provided that both sides of the lap are welded. Such joints may not be used in cargo tanks and process vessels for liquefied gases.

6. Corner welds and similar welded joints which are subjected to considerable flexural stresses under adverse conditions of fabrication or service are only acceptable if TL raises no objection to the method of execution.

7. Holes and cut-outs in or immediately adjacent to welds, especially longitudinal welds, shall be avoided wherever possible.

8. Butt-welded joints in walls under pressure shall not be intersected by fillet welds of fitments. If intersection of fitments with vessel welds cannot be avoided, sufficiently large cut-outs shall be made in the fitments in the area of the butt welds in the vessel.

9. Weld preparation for welds between the vessel wall and domes and between the domes and the corresponding nozzles shall be carried out in accordance with recognized standards.

All welds on nozzles, domes and other components which penetrate the pressure vessel and all welds

between flanges and vessel or nozzle must be welded with full penetration over the entire wall thickness of the vessel or the nozzle.

As an exception, other joints without full penetration may, with TL's consent, be used for small diameter nozzles in the dome.

**10.** Bearings, tank mountings and other fitments which may induce stresses in the walls of the vessel shall be joined to the vessel wall with adequately dimensioned doubling plates or transition pieces.

**11.** Fillet welds of sockets, tank stiffeners and fitments which may induce stresses in the walls of the vessel shall be laid down in more than one pass.

**12.** Doubling plates, flanges, mountings, lifting lugs and other welded fitments must be adapted to the contour of the vessel. All parts must be welded prior to any heat treatment and before pressure testing. An exception to this rule may be allowed in the case of parts subsequently attached to doubling plates or transition pieces.

**13.** Welding of components from ferritic steels in cold-formed areas where the outer fibres have been stretched by more than 5 % ( $D_m < 20 \cdot s$  for cylindrical shell rings) is only allowed if the effects of cold-forming have been cured by means of appropriate heat treatment.

This shall generally be accomplished by normalizing heat treatment or quenching and tempering. This requirement may be waived if proof is furnished that the properties of the material are no more than insignificantly impaired with regard to the intended use.

**14.** Every weld in a pressure vessel component shall be marked in such a way that its location remains recognizable and the welder concerned can be identified at any time. Both of these may be evidenced either by stamping the weld accordingly or by making entries in drawings, welding schedules or other records.

## H. Post-Weld Heat Treatment

**1.** Welded components must be heat-treated after welding in accordance with the stipulations of the relevant standards or TL's approval document.

**1.1** The post-weld heat treatment shall normally consist of stress relief heat treatment.

**1.2** Components fabricated from steels which have undergone normalizing heat treatment shall be subjected to normalizing heat treatment if:

- The required properties of the welded joint can only be established by normalizing heat treatment

or

- The component has undergone hot-forming after welding, unless hot-forming was completed within a temperature range equivalent to normalizing heat treatment.

**1.3** Components fabricated from quenched and tempered steels shall be subjected to quenching and tempering if:

- The required properties of the welded joint can only be established by quenching and tempering

or

- The component has undergone hot-forming after welding.

If, in the case of air-hardened and tempered steels, the hot-forming of the component was on the whole performed under the conditions applicable to normalizing heat treatment, tempering alone is sufficient.



**1.4** Cargo tanks for liquefied gases fabricated from carbon-manganese steels or 0,5 % nickel steels and designed for service at temperatures below  $-10^{\circ}\text{C}$  shall be subjected to stress relief heat treatment, unless 2.4 applies.

**1.5** For high-alloy steels with a ferritic or austenitic structure and nickel alloy steels tough at sub-zero temperatures with the exception of 0,5 % nickel steel, the need for and method of heat treatment shall be determined separately (see also, Section 9, E.).

**2.** Except in the case of the tanks described in 1.4, post-weld heat treatment may be dispensed with if the following conditions are met:

**2.1** Prior to welding, the materials must be in the heat-treated condition specified in the relevant standards or in TL's approval document. This condition is also deemed to be met if the required heat-treated condition is only attained during subsequent fabrication.

**2.2** The nominal wall thickness at the joints may not exceed 30 mm.

**2.3** In the chemical composition (melt analysis) of the base material and the weld metal, the following contents may not be exceeded:

C 0,22 %, Si 0,50 %, Mn 1,40 %,  
Cr 0,30 %, Cu 0,30 %, Mo 0,50 %,   
Ni 0,30 %, V 0,20 %;

In this context, the following conditions shall also be satisfied:

$\text{Cr} + \text{Ni} \leq 0,30 \% \text{ and } \text{Mn} + \text{Mo} + \text{V} \leq 1,6 \%$ .

These conditions may be relaxed in the case of steels which have been rendered resistant to brittle fracture and hardening by special metallurgical measures. Their suitability and properties shall be demonstrated to TL after an adequate period of proving. The steels' resistance to brittle fracture, resistance to hardening and weldability must be equivalent to those of

steels falling within the above analytical limits. For the weld metal, at a C content  $\leq 0,10 \%$  the Si content shall be  $\leq 0,75 \%$ , the Mn content  $\leq 2,0 \%$  and the sum of the Mn, Mo and V contents  $\leq 2,5 \%$  if welding consumables are used which produce a weld metal with a particularly high toughness, e.g. by using welding consumables with basic characteristics.

**2.4** If, in the case of cargo tanks for liquefied gases fabricated from carbon-manganese steels or 0,5 % nickel steels and designed for service at temperatures below minus  $10^{\circ}\text{C}$ , heat treatment is on the whole not possible due to the dimensions of the tank, mechanical destressing shall be carried out after welding.

For this purpose, individual components of complex design, e.g. domes, sumps, rings and other components which penetrate the casing of the tank, must first be welded to the adjoining shell or bottom plates and subjected with them to stress relief heat treatment before being attached to the tank structure.

**3.** If carbon-manganese or nickel alloy steels are welded with austenitic consumables, they shall not be heat-treated after welding.

**4.** Documentary proof of the heat treatments described in 1.1 to 1.4 shall be provided by means of a works certificate to EN 10204 or ISO 10474, as applicable which shall state the method, temperature and duration of the heat treatment and the method of cooling. Any special heat treatment, e.g. temporary cooling after welding prior to tempering treatment, shall be recorded in the works certificate.

## **I. Inspection of Welded Components**

**1.** All tanks, vessels and process equipment shall be subjected to a hydraulic pressure test at 1,5 times the working pressure in the presence of the Surveyor, subject to the limitation that the resulting stress shall not exceed 0,9 times the yield strength at  $20^{\circ}\text{C}$ , taking into account the positive diameter tolerance and the negative wall thickness tolerance.

This does not apply to cargo tanks of the type described in H.2.4. The component shall exhibit no leaks during the hydraulic pressure test and no permanent deformation afterwards.

2. An internal and external inspection shall be carried out on the completed vessels and process equipment, and especially of the welds and adjoining areas. The components shall have a smooth external and internal surface corresponding to the condition as manufactured, to enable significant surface defects to be detected. Vessels fabricated from austenitic steels must be pickled on the inside. At the same time, measurements shall be carried out to determine:

### 2.1 External circumference

The measurements shall be spaced at approx. 1 – 2 m intervals over the entire length of the component, depending on the length of the vessel. The measurements of the external circumference shall be used to determine the average outside diameter. The outside diameter of the shell rings and vessels may not vary from the stipulated outside diameter by more than  $\pm 1,5\%$ .

### 2.2 Out-of-roundness

The measurements shall be spaced at approximately 1 – 2 m intervals over the entire length of the component.

The out-of-roundness

$$U = \frac{2 \cdot (D_{\max} - D_{\min})}{D_{\max} + D_{\min}} \cdot 100\%$$

shall not exceed the following values:

**Table 14.4 Out-of-roundness**

Ratio of wall thickness to diameter	Maximum acceptable out-of-roundness
$s/D \leq 0,01$	2,0 %
$0,01 < s/D \leq 0,1$	1,5 %
$s/D > 0,1$	1,0 %

In calculating the out-of-roundness, the elastic deformations arising from the component's own weight shall be discounted. Isolated bulges and dents must also lie within the tolerances. In addition, the bulges and dents must have a flat profile and their depth, measured as a deviation from the normal roundness or from the shell line, as applicable, must not exceed 1 % of the length or width of the dent or bulge.

### 2.3 Axial non-linearity

The axial non-linearity shall not exceed 0,5 % of the cylindrical length.

### 2.4 Camber or flattening

The degree of camber or flattening in the area of the longitudinal welds, measured as a deviation from the normal roundness with a template length of 500 mm, may not exceed the dimension "a".

Depending on the ratio of the average diameter  $d_m$  to the wall thicknesses of the vessel or shell ring, the following applies:

- $a \leq 10$  mm for shell rings:  $\frac{d_m}{se} < 40$
- $a \leq 5$  mm for shell rings:  $\frac{d_m}{se} \geq 40$

### 2.5 Wall thickness of the welds and the adjoining plate areas

The wall thickness in the plate must lie within the tolerance permitted for the plate.

3. To show that the requirements stated in 1 and 2 are met, the manufacturer shall issue an acceptance test certificate 3.1B to EN 10204 or ISO 10474, as applicable and present it to the Surveyor at the final acceptance testing of the vessels.

### 4. Production Tests

The production test comprises non-destructive testing of

the component and quality testing of test pieces (mechanical and technological tests).

#### 4.1 Non-destructive testing

The performance of the tests is subject to the provisions of Section 10.

##### 4.1.1 Non-destructive testing of cargo tanks for the carriage of liquefied gases

4.1.1.1 The following welds shall be tested:

- All butt welds in the pressure structure (shells, ends, domes, sumps) shall be subjected to X-ray radiographic inspection over their entire length. In addition, at least 10 % of the weld length shall be tested for surface cracks.
- Fillet welds at the joint between the central longitudinal bulkhead and the tank casing of twin tanks or similar structures shall be subjected to ultrasonic or, where this is not possible, X-ray radiographic inspection over their entire length. In addition, at least 10 % of the weld length shall be tested for surface cracks.
- 10 % of the butt-welded joints of supporting rings in tanks shall be subjected to X-ray radiographic inspection. In the case of fillet welds between the web and the tank wall and between the web and the girder plate, at least 10 % of the weld length shall be tested for surface cracks.
- All butt and fillet welds of nozzle weldments, e.g. sockets, domes, sumps, rings, and of reinforcing plates around cutouts shall be tested for surface cracks over their whole length.
- Fillet welds of fitments welded to the tank which may induce stresses in the tank wall, e.g. lifting lugs, feet, brackets, shall be tested for surface cracks over their whole length.
- Full root penetration nozzle connections in the pressure structure shall undergo ultrasonic or radiographic inspection if the attachment wall

thickness at the pressure structure is > 15 mm and the inside diameter of the nozzle is  $\geq 120$  mm.

- If cargo tanks are to be mechanically de-stressed, all points with geometry-related stress concentrations, such as the seams of socket weldments or fitments, shall afterwards be tested for cracks by the magnetic particle or dye penetrant method.

4.1.1.2 If radiographic inspection is to be partly replaced by ultrasonic inspection, the method and scope must be authorized by **TL** beforehand.

4.1.1.3 Notwithstanding 4.1.1.2, **TL** may require radiographic inspection to be supplemented by ultrasonic testing and vice versa if considered necessary in special cases.

4.1.1.4 Isotopes (Ir 192) may only be used if the use of an X-ray tube is impossible for technical reasons.

##### 4.1.2 Non-destructive testing of pressure equipment with a weld factor $v > 0,85$

4.1.2.1 The following welds shall be inspected:

- Longitudinal welds shall be subjected to radiographic inspection over their entire length and circumferential welds over 25 % of their length. In addition, at least 10 % of the weld length shall be tested for surface cracks.
- All butt and fillet welds of weld-in components and reinforcing plates around cut-outs shall be tested for surface cracks over their entire length. The same applies to fitments if they are capable of inducing stresses in the wall of the vessel.
- The attachment welds of nozzles with an inside diameter  $\geq 120$  mm and a thickness of the attachment cross section > 15 mm shall undergo radiographic or ultrasonic inspection.

**4.1.2.2** Where the radiographic inspection is to be replaced by ultrasonic inspection, the process and scope of the test must be authorized by TL beforehand. TL may prescribe an ultrasonic inspection to supplement the radiographic inspection where there are doubts in interpretation of radiographic exposures.

#### 4.1.3 Non-destructive testing of pressure equipment with a weld factor $v \leq 0,85$

The manufacturer shall test the components at random in the course of his quality assurance procedures and shall present the results to the Surveyor at the vessel inspection. For this purpose, around 2 % (10 % in the case of wall thicknesses over 15 mm) of the longitudinal welds shall undergo radiographic or ultrasonic inspection, which shall include the junctions between longitudinal and circumferential welds.

#### 4.1.4 Inspection criteria

The non-destructive testing shall not reveal any major deficiencies in the weld. These include: cracks, lack of sidewall fusion and, in the case of single-side welds, inadequate root penetration.

Other defects, e.g. pores and slag, shall be assessed in accordance with recognized codes of practice, e.g. AD Code HP 5/3 or the ASME Boiler and Pressure Vessel Code, Section VIII.

## 4.2 Quality inspection of test pieces

### 4.2.1 Quality inspection of cargo tanks for the carriage of liquefied gases

**4.2.1.1** On all tanks for the carriage of liquefied gases, one test piece as shown in Fig. 14.4 shall be welded on to every 50 m of butt weld (longitudinal and circumferential welds). The location of the test pieces shall be such that every welding position is covered. Wherever possible, they shall be made as extensions of the vessel seams and shall be welded together with the vessel seam in the same operation. If this is not feasible in exceptional cases, the test pieces shall be attached

beside the relevant tank weld and welded immediately on completion of the associated section of the weld under the same conditions as were used for the actual weld. The test pieces shall be stamped by TL expert before being removed from the tank. The positions and numbers of the test pieces shall be marked on the tank and indicated in the inspection schedule.

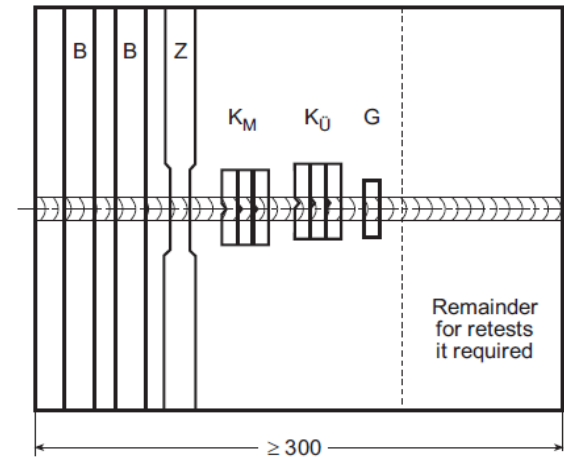

**Fig. 14.4 Test piece for production tests**

**4.2.1.2** The test pieces shall be subjected to the following tests (for shapes of specimens, see also, Section 11):

- Tensile test on one specimen (Z), shape of specimen according to EN ISO 4136; however, test length = width of weld + at least 80 mm.
- Technological bend test (B) to EN ISO 5173 on two specimens (one specimen each with opposite sides of the weld in tension). On the side in tension, after machining off the weld reinforcement the original surface of the test piece shall be preserved to the greatest possible extent. Sizeable depressions such as undercuts and root notches shall not be repaired.
- Notched bar impact tests on ISO V-notch specimens in accordance with EN ISO 9016 (DIN 50115), taking from each test piece one set of specimens with the notch in the centre of the weld metal (K<sub>M</sub>) and one set located at a point in the heat-affected zone (K<sub>Ü</sub>) at which the lowest impact energy values were measured in the welding procedure test.

- Structure examination (G) of one specimen (macrographic specimen).
- Hardness testing of the structure examination specimen according to d).
- A radiographic inspection in accordance with ISO 17636 shall be performed prior to sectioning of the test pieces.

#### **4.2.2 Quality inspection of pressure equipment with a weld factor $v > 0,85$**

**4.2.2.1** In the fabrication of all vessels, a test piece as shown in Fig. 14.4 is to be welded at the same time, regardless of the number of melts used for the plates. Two test pieces are required if there are more than five rings per pressure vessel.

**4.2.2.2** The test pieces shall be subjected to the scope of testing described in 4.2.1.2; however, the notched bar impact test specimens shall be prepared as follows:

- One set of notched bar impact test specimens with the notch in the centre of the weld (KM) shall be taken from each test piece.

- In addition, one set of notched bar impact test specimens shall be taken from the transition zone (KÜ) for:
  - all process pressure vessels with a design temperature below 0 °C
  - all alloy steels
  - all unalloyed steels where the wall thickness in the area of the weld is over 30 mm.

#### **4.2.3 Quality inspection of pressure equipment with a weld factor $v \leq 0,85$**

The manufacturer shall perform random quality inspections on his components as part of his quality assurance procedures in accordance with 4.2.2. These inspections shall cover 2 % of the components, but shall be performed at least one test piece a year for each material group and welding process. The results of the quality inspections shall be presented to TL's expert at the acceptance testing of pressure vessels.

#### **4.2.4 Requirements**

The requirements stated in Table 14.2 and, for cargo tanks and process vessels for liquefied gases, also those stated in Table 14.3 shall be met in the quality inspection. Failing this, the associated section of weld must be machined out and rewelded and its characteristics must be verified by testing of a new test piece.

## SECTION 15

### WELDING OF PIPELINES

	<b>Page</b>
<b>A. GENERAL</b> .....	15-2
1. Scope	
2. Other Relevant Standards	
3. Pipe Classes	
<b>B. APPROVAL OF WELDING SHOPS, WELDING PERSONNEL</b> .....	15-2
<b>C. QUALITY INSPECTION RESPONSIBILITY</b> .....	15-3
<b>D. MATERIALS, WELDABILITY</b> .....	15-4
<b>E. WELDING CONSUMABLES AND AUXILIARY MATERIALS</b> .....	15-4
<b>F. WELDING PROCEDURE TESTS</b> .....	15-7
1. General	
2. Welding of Tests Pieces, Welding Procedure Specification (WPS)	
3. Test Principles, Delimitation of Scope	
4. Tests, Scope of Tests	
5. Test Requirements	
6. Storage of Specimens	
7. Validity, Extension of Welding Procedure Tests	
<b>G. WELDING TECHNIQUE</b> .....	15-9
<b>H. PREHEATING</b> .....	15-10
<b>I. HEAT TREATMENT AFTER FORMING AND WELDING</b> .....	15-10
<b>J. INSPECTION OF WELDED PIPELINES</b> .....	15-12

**A. General****1. Scope**

1.1 These Rules apply to the fabrication and testing of welded pipelines made of

- Unalloyed steels,
- High-temperature steels,
- Steels tough at subzero temperatures,
- Stainless steels.

1.2 Welded pipelines fabricated from other materials not listed in 1.1 (e.g. copper-nickel wrought alloys) may be manufactured and tested to other rules or regulations issued by TL for specific uses or other engineering regulations recognized TL.

1.3 The design and testing of pipelines joined by other processes (e.g. brazed or bonded) are subject to agreement between the manufacturer and TL head office in each individual case (see Section 1, A.1.1).

1.4 The welding joints belonging to Class I or II piping systems shall be affected by approved procedures. Consumables and welders shall meet the requirements of TL.

1.5 Joint preparations and tolerance shall be appropriate to the welding process, in accordance with TL's Rules or recognized standards.

1.6 Welding shall be done according to applicable requirements and good practice; the weld preparations and the welded joint shall be inspected as may be necessary in the course of fabrication and after completion of the welding heat treatment.

1.7 The following requirements apply to the fabrication of Classes I and II piping systems operating at ambient or high temperature and made of steel of the types given hereunder:

.1 carbon and carbon-manganese steels having minimum tensile strength (Rm) 320, 360, 410, 460 and 490 N/mm<sup>2</sup>.

.2 low alloy carbon-molybdenum, chromium-molybdenum, chromium-molybdenum-vanadium steels having chemical composition 0,3 Mo; 1 Cr - 0,5 Mo; 2,25 Cr - 1 Mo; 5 Cr - 0,5 Mo - 0,25 V.

1.8 At the discretion of TL, these requirements may be applied also to the Class III piping systems and to repair welding of pipelines.

1.9 Refrigerated cargo installations piping systems operating at temperatures lower than -40°C will be given special consideration by TL.

**2. Other Relevant Standards**

2.1 The provisions of TL Chapter 4, Machinery, Section 16 shall also be complied with in the design and dimensioning of pipelines subject to pressure.

2.2 Cargo lines on ships designed for the bulk carriage of chemicals are also subject to the provisions of TL Rules, Chapter 8, Chemical Tankers, Section 1.

2.3 Cargo and process lines on ships designed to carry cooled liquefied gases are also subject to the provisions of TL Rules, Chapter 10, Liquefied Gas Tankers.

**3. Pipe classes**

Depending upon the nature of the pipe and its content (medium) and also the design pressure and design temperature, pipelines are classified into three pipe classes; see Chapter 4, Machinery, Section 16, Table 16.1. The type of pipe connections, welding requirements, the need for post-weld heat treatment and the scope of the non-destructive tests are stipulated in the following items or in other relevant rules, as applicable, in relation to the particular pipe class.

**B. Approval of Welding Shops, Welding Personnel**

1. All welding shops intending to perform welding work within the scope of these rules must satisfy the requirements applicable to welding shops and personnel set out in, Section 2 and must have been approved by TL. Applications for approval shall be submitted by the welding shops in good time

before starting the welding work, enclosing the information and documentation prescribed in, Section 2, A.3.

2. The welding personnel (welders and welding supervisors) and, where applicable, inspectors and inspection supervisors must satisfy the requirements set out in , Section 2, B.2., B.3. and B.4. and be recognized by **TL**. For the welder's qualification tests, see Section 3.

3. The scope of the approval is determined by the capabilities of the welding shop and by the intended range of application (pipe class, materials, welding processes, welding positions, etc.). The intended range of application shall be specified in the application for approval. For the period of validity of the approval, see Section 2, A.4. and A.5.

#### 4. Basic approval, extensions

4.1 For the welding of class III pipelines, as a general rule (basic) approval is granted first of all on the basis of a works inspection and, if necessary, welder's qualification tests in accordance with Section 3 normally for the manual arc welding (welding process 111), tungsten inert gas welding (welding process 141), gas welding (welding process 311) and/or semi-mechanized metal-arc active gas welding using solid and flux-cored wire (welding processes 135 and 136) of unalloyed tubular steels in the strength category 360 and 410 (see Chapter 2, Materials) and also comparable cast and forged steels. The range of wall thicknesses for these is determined by the scope of the valid welder's qualification tests.

4.2 This does not apply to welding in the vertical down position using these processes, for which welding procedure tests shall be performed in every case. See F.

4.3 A basic approval may be extended to include any welding procedure approvals on the basis of the welding procedure tests in accordance with , Section 4, (see also F.); in exceptional cases, however,

a limited approval may also be granted, in conjunction with a welding shop inspection, for one specific material and/or one specific welding process only.

#### C. Quality inspection responsibility

1. The manufacturer shall submit to **TL**, for inspection, drawings and other relevant documents containing at least the following information:

- The type of pipeline/medium
- The pipe grades and welding consumables to be used,
- The welding process, welding position and shape of the weld,
- The type of heat treatment, if required,
- The acceptable working pressure,
- The design temperature or, in the case of cargo and process pipelines for gas tankers, the minimum design temperature,
- The operating temperature,
- The test pressure,
- The nature and scope of the non-destructive tests,

2. If the quality or good working order of a component cannot be guaranteed or is in doubt due to inadequate or missing information in the manufacturing documents (e.g. production drawings), **TL** may demand appropriate improvements.

3. Welding shops shall ensure by means of regular in-house quality inspections during fabrication and on completion of the welding work that this work has been performed competently and satisfactorily (see Section 1, F.). For the duties and responsibilities of the welding supervisor, see also ISO 14731.



4. The welding shops are responsible for ensuring that the welding work conforms to these Rules, the approved manufacturing documents, any conditions stipulated in the approval documents and the latest state of welding practice. The inspections and checks to be performed by TL's Surveyor do not relieve the welding shops of this responsibility.

5. With regard to quality inspections and the responsibilities involved in awarding subcontracts to independent branches or suppliers or to approved or non-approved outside firms working in the welding shop (subcontractors), see Section 1, F. Subcontracting of work or employment of temporary workers shall be notified to TL.

6. The scope of the required quality inspections depends on the construction project in question. It is essential to ensure, however, that the intended materials, welding consumables and auxiliary materials are used and that the weld preparation, assembly, execution of the tack and final welds and the dimensional accuracy and completeness of the welded joints meets the requirements stated in 3. For non-destructive testing of the welded joints, see I.

7. Following internal inspection and, if necessary, repair by the welding shop, the components shall be presented to TL's Surveyor for checking at suitable stages of fabrication. For this purpose they shall be readily accessible and shall normally be uncoated. Where the previous inspection has been inadequate, the Surveyor may reject components and require that they be presented again after satisfactory workshop inspection and any necessary repair work has been performed.

8. TL is not responsible for guaranteeing that all the components and welded joints inspected to the prescribed extent (generally on a random basis) by its surveyors have been fabricated in accordance with the conditions and meet the requirements in every respect. Components or welded joints which subsequently turn out to be defective may be rejected or their repair may be demanded even if acceptance testing has already been carried out.

#### **D. Materials, Weldability**

1. The materials selected must be appropriate for the intended purpose, with allowance made for mechanical and thermal stresses. The characteristics of materials subjected to further processing shall be such that they are able to withstand the operating loads.

2. Welded structures may only be fabricated using base materials of proven weldability. Materials for pipelines (pipes, flanges, adapting pieces, fittings) must comply with the requirements set out in the relevant sections Chapter 2, Materials. Other comparable materials may only be used after TL has given its approval in each individual case.

3. Pipeline materials for cargo and process lines for liquefied gases must also meet the impact energy requirements at the stipulated test temperature; see Tables 15.1 to 15.3.

#### **E. Welding Consumables and Auxiliary Materials**

1. The welding consumables and auxiliary materials must enable a welded joint to be made which is appropriate to the pipeline material, the operating temperature and the conditions of service. The suitability of the welding consumables must also have been verified under the conditions prevailing in any potential heat treatment.

2. All the welding consumables and auxiliary materials used (e.g. covered electrodes, wire-gas combinations, wire-flux combinations, etc.) must have been approved by TL in accordance with , Section 5. They may also, however, be approved if tested at the same time as the welding process and restricted to the user's works (see, Section 4, B.3.2 and Section 5, A.1.4).

3. Welding consumables for steels tough at subzero temperatures must also meet the impact energy requirements for the weld metal at the stipulated test temperatures; see Table 15.2.

Table 15.1 Requirements as per item 5 for testing of welded joints in pipelines

Type of Test	Requirements		
Tensile test transversely to weld	Tensile strength as stipulated for the base material or in the assessment of suitability for the welding consumable		
Notched bar impact test (1) on ISO V-notch specimens taken from the centre of the weld metal	All pipelines except those indicated below	As stipulated for the base material, at least $\geq 27$ J. Test temperature as for testing of base material. When using ferritic-austenitic, austenitic and nickel-base alloy welding consumables, $\geq 40$ J.	
	Cargo and process lines of gas tankers	Test temperature as shown in Table 15.2. When using ferritic welding consumables, $\geq 27$ J (2); when using ferritic-austenitic, austenitic and nickel-base alloy welding consumables, $\geq 34$ J (2).	
Notched bar impact test (1) on ISO V-notch specimens taken from the weld transition zone	All pipelines except those indicated below	$\geq 27$ J (2) test temperature as for testing of base material	
	Cargo and process lines of gas tankers	Test temperature as shown in Table 15.2. $\geq 27$ J for carbon-manganese steels, $\geq 34$ J for nickel alloy steels, $\geq 41$ J for austenitic steels.	
Technological bend test	<b>Bending angle, degrees</b>	<b>Strength category</b>	<b>Bending mandrel diameter</b>
	180° (3)	Ferritic steels with minimum tensile strength $< 430$ N/mm <sup>2</sup> minimum tensile strength $\geq 430$ to $< 460$ N/mm <sup>2</sup>	2 × a 2,5 × a
	180° (3)	Austenitic stainless steels and austenitic steels tough at subzero temperatures High-temperature austenitic steels Ferritic steels with a minimum tensile strength $\geq 460$ N/mm <sup>2</sup>	2 × a 3 × a 3 × a
	If a bending angle of 180 degrees is not attained, the following applies:		
	$\geq 90^\circ$	Elongation ( $L_0$ = width of weld + wall thickness, simetrically to weld) $\geq$ minimum elongation A5 of base material	
	Or $< 90^\circ$	Elongation over width of weld $> 30$ % and faultless appearance of fracture	
	Metallographic examination	The macrographic specimen of the welded joint must reveal a satisfactory weld build-up and full penetration of the weld. Micrographic specimens are to be examined for cracks. Only hot cracks are acceptable, and then only if they are few in number and widely scattered and agreement has been reached with the expert as to their acceptability with regard to the material and the range of application.	
Hardness testing	The hardness in the heat-affected zones shall not exceed 350 HV 10. Hardness peaks in excess of this figure in narrow transition zones shall not give rise to complaints if the outcome of the technological tests meets the requirements.		
(1) For the requirements applicable to specimens with a depth of less than 10 mm, see Table 15.3.			
(2) Only one impact energy value may be lower than the minimum mean value, and only by max. 30 %.			
(3) The 180-degree requirement is deemed to have been met if the bend test was performed according to ISO 5173 and pressure was applied by the supports without cracks appearing.			

**Table 15.2 Test temperatures for notched bar impact testing of pipe steels tough at subzero temperatures**

Type of steel	Standard Designation	Standard	Minimum design temperature [°C]	Test temperature [°C]
Carbon and carbon-manganese steels	TT St 35 N TT St 35 V	EN 10216-4	- 40 - 50	5°C below minimum design temperature, but not exceeding – 20 °C
Nickel alloy steels containing				
0,5 % Nickel	13MnNi63		- 55	- 60
3,5 % Nickel	10Ni14		- 90	- 95
5 % Nickel	12Ni19	-105	- 110	
9 % Nickel	X8Ni9	- 165	- 196	
Austenitic steels (1) (2) (AISI 304 L) (AISI 316 L) (AISI 321) (AISI 347)	X2CrNi19-11 X2CrNiMo18-14-3 X6CrNiTi18-10 X6CrNiNb18-10	EN 10217-7 EN 10216-5	- 165	- 196

(1) The designations in brackets are comparable pipe steels to AISI standards.  
(2) Where austenitic pipe steels are used for design temperatures not less than -55 °C, a test temperature 5°C below the minimum design temperature but not exceeding -20 °C may be agreed upon.

**Table 15.3 Impact energy requirements for specimens of reduced size**

Required impact energy KV for standard specimens (1)	Required impact energy KV for specimen sizes (1)	
	7,5 × 10 mm	5 × 10 mm
10 × 10 mm		
[J]	[J]	[J]
27 (19)	22 (16)	18 (13)
34 (24)	28 (20)	23 (16)
41 (27)	34 (24)	27 (22)

(1) Figures in brackets are for the minimum individual value.

4. Welding consumables and auxiliary materials specified in a procedure approval document with a maker's or brand name (see F.3.5) may only be replaced by equivalent consumables approved by TL with an appropriate quality grade if this is explicitly stated in the respective approval document. Failing this, TL's agreement shall be obtained.

5. The welding consumables and auxiliary materials may only be used in the approved welding positions. The manufacturers' recommendations and

instructions for welding (e.g. type of current and polarity) shall be followed.

6. The welding consumables and auxiliary materials (especially hydrogen-controlled, basic-covered electrodes and basic welding fluxes) shall be re-dried before use in accordance with the manufacturer's instructions (observe maximum drying time!) and stored in a dry place (in heated containers or the like) at the workplace.

## F. Welding procedure tests

### *Preliminary remark:*

*In contrast to earlier issues of these Rules, welding procedure tests shall be performed in accordance with EN ISO 15607-EN ISO 15614, as applicable. This rule essentially covers requirements applicable to the welding of pipelines over and above those set out in EN ISO 15614-1.*

### 1. General

Only those welding procedures whose suitability for the application in question is evident from general experience or has been verified by means of a welding procedure test in accordance with , Section 4 and the following provisions may be used. Table 4.1 in, Section 4 gives a list of necessary verifications. The welding procedures must have been approved by **TL** for the particular welding shop in question as part of the welding shop approval (see also B.).

### 2. Welding of Test Pieces, Welding Procedure Specification (WPS)

**2.1** A preliminary "manufacturer's" welding procedure specification (pWPS) setting out all the major parameters shall be produced by the welding shop for the welding of test pieces in accordance with EN ISO 15609-1, as applicable.

**2.2** **TL**'s expert shall select one of the welders whose names are to be supplied by the manufacturer to weld the test pieces.

**2.3** The test pieces shall be made from materials whose properties are proven in accordance with the requirements specified in Chapter 2, Materials. Pre-treatment and after-treatment of the test pieces by preheating, heat treatment and the like is only permitted if stipulated for these materials during actual fabrication.

**2.4** The types of weld and welding positions employed in the fabrication process shall be qualified in the welding procedure test.

**2.5** The shape and dimensions of the test pieces are specified in EN ISO 15614-1.

## 3. Test Principles, Delimitation of Scope

Except in the case of basic approvals for pipe class III (see B.4.1 and Table 4.1 in Section 4), the qualification of the welding procedure shall be ascertained in accordance with EN ISO 15607 by means of welding procedure qualification tests, for steel in accordance with EN ISO 15614-1.

The test is valid within the limits described in 3.1 to 3.7.

The scope of the welding procedure test is specified by **TL** in writing. Any exceptions require the performance of a supplementary test, the scope of which shall be decided by **TL**.

### 3.1 Base materials, material groups

Above and beyond the grouping system of EN ISO 15614-1, the following provisions shall be observed:

- a) For materials which have to satisfy particular corrosion conditions (e.g. resistance to caustic cracking) the welding procedure tests shall be geared to these.
- b) A welding procedure qualification performed on group 1 killed steel does not apply to unkilld steels unless they were welded using basic covered electrodes.
- c) Depending on material composition and/or the type of post-weld treatment required, **TL** may also limit the scope to the base material used in the welding procedure test.
- d) For cargo and process pipelines designed to carry liquefied gases, the test applies only to the grade of steel inspected.

### 3.2 Welding process

Recognition applies only to the welding process employed in the welding procedure test.

### 3.3 Gas welding

In gas welding a test performed on the wall thickness  $t$  shall apply to the wall thickness range  $0,75 t$  to  $1,25 t$ .

### 3.4 Welding parameters

Welding procedure tests performed on multi-pass welds do not apply to single-pass welds.

### 3.5 Welding consumables and auxiliary materials

The requirements of EN ISO 15614-1 do not apply if the filler metal used is of the same type and has been approved by TL to be under the scope of the welding procedure qualification (see E.4).

### 3.6 Heat treatment

The welding procedure test applies to the heat treated condition existing at the time of the test. Heat treatment of the test piece shall be performed so that a heat treated condition is achieved which is comparable to that of the component.

### 3.7 Special cases

For special cases, for example difficult repairs to be performed in the course of fabrication on steels which are susceptible to cracking due to hardening of the heat affected zone, welding procedure tests are necessary which are geared to these particular cases. The tests required and their scope are specified by TL in each individual case.

## 4. Tests, Scope of Tests

Testing comprises both non-destructive and destructive tests and shall be performed in accordance with EN ISO 15614-1.

Deviating from EN ISO 15614-1, the following specimens shall also be taken from the test pieces:

**4.1** Notched bar impact test on ISO V-notch specimens to EN ISO 9016 (DIN 50115) taken from the centre of the weld metal (KM) (one set of specimens per welding position) as follows:

- For cargo and process lines for gas tankers where the wall thickness is  $\geq 4$  mm **(1)**
- For other alloy steels and fine-grained structural steels where the wall thickness is  $\geq 6$  mm.

**4.2** Notched bar impact test on ISO V-notch specimens as above, but with the notch in the transition zone (KÜ) where the wall thickness is  $\geq 6$  mm.

For austenitic pipe steels, the test is only required for wall thicknesses  $\geq 10$  mm.

**4.3** Macro and micrographic specimens are required for alloy steels. In particular, micro-graphic specimens shall be examined for micro-cracks. The metallographic structure is to be described or verified by means of photographs.

**4.4** An analysis of the weld metal, except for unalloyed steels.

## 5. Test Requirements

The irregularities in the test piece must fall within the limits specified for quality level B in accordance with ISO 5817, exceptions being: excessive convexity and excessive throat thickness (fillet welds) which fall into quality level C.

For the mechanical and technological tests, Table 15.1 applies in conjunction with Table 15.2 which indicates the impact energy requirements for cargo and process lines for gas tankers.

---

**(1)** *Size of specimen and requirements for wall thickness  $< 6$  mm must be separate agreed.*

## 6. Storage of Specimens

The tested specimens and the remaining portions of the test pieces shall be stored until the report on the welding procedure test has been issued (see also Section 4, C.3.).

## 7. Validity, extension of welding procedure tests

The validity of a welding procedure test is generally 1 year provided that the preconditions under which it was granted have not significantly changed. It may be continued by means of regular verifications of quality, e.g. the results of non-destructive tests or production tests.

The welding procedure test shall be repeated if there is a break in the fabrication of pipelines or pipeline components lasting longer than one year.

## G. Welding Technique

1. Welds must exhibit full penetration over their entire cross section and must not have any cracks or lack of fusion defects. The welds shall be made in the workshop as far as possible.

2. Permanent backing rings shall be of such a shape that they can neither impede the flow nor cause corrosion. Backing rings shall be made of pipe steels of the same composition as the base metal; with unalloyed and low-alloy pipe grades, they may also, where appropriate, be made of low-carbon steels ( $C \leq 0,10 \%$ ).

3. In the case of pipelines fabricated from austenitic steels and all other pipelines with working pressures in excess of 10 bar and design temperatures of  $-10^{\circ}\text{C}$  and below, permanent backing rings may not be used on principle.

4. For butt-welded joints in lines with design temperatures below  $-10^{\circ}\text{C}$  and for all stainless pipe steels, the root passes shall as a rule be laid down by

tungsten inert gas welding with gas shielding on both the inside and the outside of the pipe.

5. Wherever possible, adequately dimensioned pipe fittings shall be used for branches. Where outward flanged pipeline connections are used, the inside diameter ratio shall not exceed 0,8. Outward flanges shall be made by established methods.

6. The preparation of welds must conform to recognized standards.

Wherever possible, welding edges shall be prepared by machining or with a mechanically guided cutting torch. Slag, scale, drag lines and other irregularities shall be removed. Where necessary, the same applies to the heat-affected boundary zone in the case of austenitic steels. The welding edges of steel forgings and castings must be machined.

7. Tack welds may only be made with consumables which are also compatible with the pipe material. Where tack welds are to be left in place, they must be of the same quality as the root welds. The rules for preheating shall also apply to tack welding.

8. Flange-pipe joints shall be chosen in accordance with the Chapter 4, Machinery, Section 16 in relation to the pipe class.

9. Pipeline sections to be welded must be axially aligned. The internal misalignment of the pipe ends may not exceed the values stated in Table 15.4.

10. Weld reinforcements shall lie within the following tolerances (see Fig. 15.1):

Cover pass reinforcement:

$$\ddot{U}_D \leq 1 + 0,1 B \quad [\text{mm}]$$

Root pass reinforcement:

$$\ddot{U}_W \leq 1 + 0,3 b \quad [\text{mm}]$$

(see also ISO 5817, quality level B)

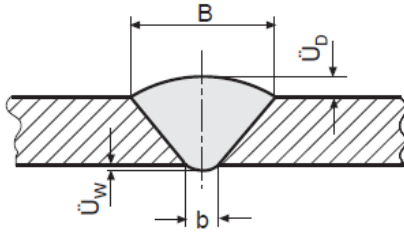

**Fig. 15.1 Weld reinforcements**

11. Welding of pipeline components made of ferritic steels in areas subjected to cold forming where the outer fibres have been stretched by more than 5 % (e.g. where pipe bending is carried out with a radius  $r_m < 10 D_a$ ) is only allowed if the effects of cold-forming have been eliminated by means of appropriate heat treatment. This shall generally be accomplished by normalizing heat treatment or quenching and tempering.

This requirement may be waived if proof is furnished that the properties of the material are no more than insignificantly impaired with regard to the intended use or if the conditions specified in para. H.1. or H.2., as applicable, are met.

## H. Preheating

Preheating of the different types of steels will be dependent upon their thickness and chemical composition as indicated in Table 15.5.

In any case, dryness is to be ensured using, if necessary, suitable preheating.

Table 15.5 values are based on use of low hydrogen processes; consideration should be given to using higher preheating temperatures when low hydrogen processes are not used.

## I. Heat-treatment after forming and welding

1. The heat treatments are not to impair the specified properties of the materials; verifications may be required to this effect as necessary.

The heat treatments are preferably to be carried out in suitable furnaces provided with temperature recording equipment. However, also localized heat treatments on a sufficient portion of the length way of the welded joint, carried out with approved procedures, can be accepted.

**Table 15.4 Tolerances on internal misalignment of pipe ends**

Type of joint	Inside diameter Di	Wall thickness t [mm]	Tolerances on internal misalignment
With permanent backing rings	Any	Any	max. 0,5 mm
Without backing rings	Di < 150	t ≤ 6	t/4 max. 1 mm
	150 ≤ Di < 300	t ≤ 9.5	t/4 max. 1.5 mm
	300 ≤ Di	any	t/4 max. 2,0 mm
	any	t > 9.5	t/4 max. 2,0 mm

**Note:**  
 For Class III piping systems, the requirements for alignment tolerances may be waived at the discretion TL.  
 Assembling for welding is to be appropriate and within the prescribed tolerances.  
 Tack welds should be made with an electrode suitable for the base metal; tack welds which form part of the finished weld should be made using approved procedures.  
 When welding materials require preheating, the same preheating should be applied during tack welding.

Table 15.5 Preheating

Type of steel		Thickness of thicker part (mm)	Minimum preheating temperature (°C)
C and C/Mn steels	$C + \frac{Mn}{6} \leq 0,40$	$\geq 20$ (2)	50
	$C + \frac{Mn}{6} > 0,40$	$\geq 20$ (2)	100
0,3 Mo		$> 13$ (2)	100
1 Cr 0,5 Mo		$< 13$	100
		$\geq 13$	150
2,25 Cr 1 Mo and 0,5 Cr 0,5 Mo 0,25 V (1)		$< 13$	150
		$\geq 13$	200

(1) For these materials, preheating may be omitted for thicknesses up to 6 mm if the results of hardness tests carried out on welding procedure qualification are considered acceptable by TL.

(2) For welding in ambient temperature below 0°C, the minimum preheating temperature is required independent of the thickness unless specifically approved by TL.

2. Hot forming is to be generally carried out in the temperature range 1000°C - 850°C for all grades; however, the temperature may decrease to 750°C during the forming process.

2.1 When the hot forming is carried out within this temperature range, the following generally applies:

- For C, C-Mn and C-Mo steels, no subsequent heat treatment is required;
- For Cr-Mo and C-Mo-V steels, a subsequent stress relieving heat treatment accordance with Table 15.6 is required.

2.2 When the hot forming is carried outside the above temperature range, a subsequent new heat treatment in accordance with Table 15.7 is generally required for all grades.

3. After cold forming, when  $r < 4D$  (where  $r$  is the mean bending radius and  $D$  is the outside diameter of pipe) consideration is to be given to a complete heat

treatment in accordance with Table 15.7; in any case, a stress relieving heat treatment in accordance with Table 15.6 is required for all grades other than carbon and carbon-manganese steels with  $R_m$  320, 360 and 410.

Table 15.6 Hot forming

Type of steel	Thickness of thicker part (mm)	Stress relief heat treatment temperature (°C)
C and C/Mn	$\geq 15$ (1,3)	550 to 620
0,3 Mo	$> 15$ (1)	580 to 640
1 Cr 0,5 Mo	$> 8$	620 to 680
2,25 Cr 1 Mo and 0,5 Cr 0,5 Mo 0,25 V	Any (2)	650 to 720

(1) When steels with specified Charpy V notch impact properties at low temperature are used, the thickness above which postweld heat treatment shall be applied may be increased by special agreement with TL.

(2) Heat treatment may be omitted for pipes having thickness  $< 8$  mm, diameter  $< 100$  mm and minimum service temperature 450°C.

(3) For C and C-Mn steels, stress relieving heat treatment may be omitted up to 30 mm thickness by special agreement with TL.

Table 15.7 Hot forming above 1000-850°C range

Type of steel	Heat treatment temperature (°C)
C and C-Mn	Normalizing 880 to 940
0,3 Mo	Normalizing 900 to 940
1 Cr – 0,5 Mo	Normalizing 900 to 960 Tempering 640 to 720
2,25 Cr – 1	Normalizing 900 to 960 Tempering 650 to 780
0,5 Cr – 0,5 Mo – 0,25 V	Normalizing 930 to 980 Tempering 670 to 720

4. Stress relieving heat treatment after welding for other than the oxy-acetylene welding process is required as indicated in Table 15.6 depending on the type of steel and thickness.



The temperature ranges given in the Table are in accordance with common practice. Other values for upper and lower temperature limits may be stipulated by **TL**.

The stress relieving heat treatment is to consist in heating the piping slowly and uniformly to a temperature within the range indicated in the Table 15.6, soaking at this temperature for a suitable period, in general one hour per 25 mm of thickness with minimum half an hour, cooling slowly and uniformly in the furnace to a temperature not exceeding 400°C and subsequently cooling in a still atmosphere.

In any case, the heat treatment temperature is not to be higher than  $t_T = - 20^\circ\text{C}$  where  $t_T$  is the temperature of the final tempering treatment of the material.

**5.** Unless otherwise specified, for oxyacetylene welding, the heat treatment indicated in Table 15.7 depending on the type of steel is required.

The temperature ranges given in the Table are in accordance with common practice. Different values for upper and lower temperature limits may be stipulated by **TL**.

## **6. Heat Treatment of Pipe Fittings**

The provisions of Chapter 2, Materials, Section 4, F.

## **7. Post-Weld Heat Treatment**

**7.1** Heat treatment shall be applied in accordance with Section 9. Welded joints in pipelines fabricated from ferritic steels shall be heat-treated after welding in accordance with the stipulations of the relevant standards or **TL**'s approval document where the conditions stated in 7.1.1 and 7.1.2 apply. Unless otherwise stipulated, the post-weld heat treatment shall consist of stress relief heat treatment.

**7.1.1** Electrically fusion-welded pipe joints shall undergo stress relief heat treatment if the limit wall thicknesses shown in Table 15.6 in relation to the type of pipe steel are exceeded.

**7.1.2** Gas fusion-welded joints shall undergo normalizing heat treatment or quenching and tempering, depending on the type of material, if the wall thickness of the pipe exceeds 3,2 mm or the outside diameter exceeds 88,9 mm.

**7.1.3** For pipes made of nickel alloy steels tough at subzero temperatures, the need for post-weld heat treatment and the limit wall thicknesses will be determined during the welding procedure test.

**7.2** For pipelines fabricated from austenitic and austenitic- ferritic steels, post-weld heat treatment is generally unnecessary if the pipeline materials are in the proper heat-treated condition prior to welding.

## **J. Inspection of Welded Pipelines**

The inspection shall consist of an internal hydraulic pressure test and non-destructive tests. The non-destructive tests shall be performed in accordance with Section 10.

**1.** Completed pipeline sections shall be subjected to a hydraulic pressure test at 1,5 times the working pressure in the presence of the Surveyor. The pipeline section may not exhibit any leaks during the hydraulic pressure test or any permanent deformation afterwards.

**2.** An external and, wherever possible, also an internal inspection of the completed pipeline sections and especially of the welds shall be performed. For the inspections, the sections shall have a smooth external and internal surface corresponding to the asfabricated condition which enables major surface defects to be detected, and pipelines fabricated from austenitic and austenitic-ferritic steels must be free from harmful temper colours.

**3.** The misalignment of pipe ends, the external weld reinforcements and - where accessible - the internal weld reinforcements shall be checked. They must lie within the tolerances specified in G.9. and G.10.

4. The butt-welded joints of the following pipelines shall be subjected to radiographic inspection as follows:

- All pipelines in pipe class I: 100%.

A reduction in the scope of the test may be agreed on application for pipelines with an inside diameter  $\leq 75$  mm, provided that proof is furnished that the results are consistently good and that the percentage of repairs is relatively low.

- All cargo and process lines of gas tankers with a service temperature below  $-10^{\circ}\text{C}$ : 100 %.

A reduction in the scope of the test may be agreed on application for pipelines with an inside diameter  $\leq 75$  mm or wall thicknesses  $\leq 10$  mm provided that proof is furnished that the results are consistently good and that the percentage of repairs is relatively low.

- All pipelines in pipe class II: 10 %.

A reduction in the scope of the test may be agreed on application for pipelines with an inside diameter  $\leq 100$  mm provided that proof is

furnished that the results are consistently good and that the percentage of repairs is relatively low.

- Where the execution of welding operations gives rise to doubts as to the quality of the welded joints, the TL may also call for a random radiographic test to be carried out on the butt welds of pipe class III.

The radiographic inspection shall as a rule be performed with an X-ray tube. With TL's consent, radiographic inspection may be replaced by ultrasonic inspection for ferritic steel pipes with wall thicknesses  $\geq 20$  mm.

5. Fillet welds of flanges, sockets and nipples of pipelines in class I, including cargo and process lines of gas tankers, shall be 100 % tested for surface cracks.

For pipelines in pipe class II and III, random testing covering 10 % of the welds is required.

**Note:**

*The scope of the tests to be applied to series-manufactured pipe fittings is specified separately; see Chapter 2, Materials, Section 4, F.*

**SECTION 16****WELDING OF MACHINERY COMPONENTS**

	<b>Page</b>
<b>A. GENERAL</b> .....	<b>16-2</b>
1. Scope	
2. Other Relevant Rules and Regulations	
<b>B. APPROVAL OF WELDING SHOPS, WELDING PERSONNEL</b> .....	<b>16-2</b>
1. Works and Works Divisions	
2. Requirements, Scope of Approval	
3. Basic Approval, Extensions	
<b>C. QUALITY INSPECTION, RESPONSIBILITY</b> .....	<b>16-3</b>
<b>D. MATERIALS, WELDABILITY</b> .....	<b>16-4</b>
<b>E. WELDING CONSUMABLES AND AUXILIARY MATERIALS</b> .....	<b>16-4</b>
<b>F. WELDING PROCEDURE TESTS</b> .....	<b>16-4</b>
1. General	
2. Scope of Tests, Test Schedule, Limits of Application	
3. Test Pieces, Fabrication (Welding), (Postweld) Heat Treatment	
4. Non-Destructive Tests	
5. Sectioning of Test Pieces, Type and Number of Specimens	
<b>G. DESIGN, WELDING TECHNIQUE</b> .....	<b>16-10</b>
<b>H. POST-WELD HEAT TREATMENT</b> .....	<b>16-11</b>
<b>I. INSPECTION OF WELDED COMPONENTS</b> .....	<b>16-11</b>

**A. General****1. Scope**

1.1 These Rules apply to all welding work performed during the fabrication and repair of machinery components such as bedplates, frames, housings for diesel engines, gear boxes, wheel bodies, steering engine housings, quadrants and similar components of a corresponding nature.

**Note:**

*Since the machinery components listed above are mostly "steel components" which are not significantly different from hull structures in their materials, welding processes and welding works (see also Table 4.1 in Section 4), the specifications set out in Section 12 applicable to the welding of hull structures may also be applied here where no special provisions are prescribed in the following items.*

1.2 They also apply to welding work performed on machinery components such as axles or shafts, pistons, propellers, hubs, machinery tanks, hydraulic cylinders, valve housings, valves etc. where **TL** has approved welding work to be carried out on components of this kind either as a general approval or in an individual case. They apply to welding work performed in the course of new fabrications and also to repair welds on machinery components.

1.3 For the use of welding as a production process during the course of the manufacture of materials and/or semi-finished products, such as the "fabrication welding" of the forgings or castings used in machinery components (e.g. propellers), see also the Rules for Materials and the iron and steel material specification welding procedure tests for production welds made on cast steel.

**2. Other Relevant Rules and Regulations**

The design and dimensions of welded joints and also the welding technique are subject to the provisions of Chapter 2, Materials and other rules or regulations issued by **TL** for specific ranges of application. For other relevant standards, etc., see Section 1, B. of these Rules for Welding.

**B. Approval of Welding Shops, Welding Personnel****1. Works and Works Divisions**

1.1 In the following items, the term "welding shop" refers to the welding fabrication shop which may be considered an independent unit with regard to its physical and organizational situation.

1.2 Branches and subcontractors are thus generally deemed to be "independent" welding shops which have to satisfy the requirements prescribed below. In particular, every welding shop must have a welding supervisor who is a permanent member of the welding shop staff (see Section 2).

1.3 Outside firms working in welding shops may be granted approval as independent welding shops. On this and on temporary workers, see also C.3. and Section 1, F.

**2. Requirements, Scope of Approval**

2.1 All welding shops intending to perform welding work covered by these rules must satisfy the requirements relating to the welding shop and its personnel set out in Section 2 and must have been approved for this work by **TL**. Applications for approval shall be submitted by the shipyards and welding shops in good time before starting the welding work, enclosing the information and documentation prescribed in Section 2, A.3.

2.2 Welding personnel (welders, operators and supervisory staff) and where applicable inspectors and test supervisors must meet the requirements set out in Section 2, B.2., B.3. and B.4. and be recognized by **TL**. For welder's qualification tests, see Section 3.

2.3 The scope of the approval is determined by the capabilities of the welding shop and by the intended range of application (components, materials, welding processes, welding positions, etc.). The intended range of application shall be specified in the application for approval. For the period of validity of the approvals, see Section 2, A.4. and A.5.

### 3. Basic Approval, Extensions

3.1 For welding machinery components, as a general rule (basic) approval is granted first of all on the basis of a works inspection and, if necessary, welder's qualification tests in accordance with Section 3 (see also 4.) normally for manual arc welding (welding process 111) and/or for semimechanized metal-arc active gas welding using solid and flux-cored wire electrodes (welding processes 135 and 136) of normal-strength structural steels and other comparable grades of forged and cast steel. The thickness range is in this case determined by the scope of the valid welder's qualification tests.

3.2 Welding procedure tests shall be performed for other components, materials and/or welding processes, see F. Single-wire submerged arc welding (welding process 121) may also be covered in the basic approval described in 3.1 on the basis of documentary proof of satisfactory operational handling (see F.1.3) (for the normal welding in one run on each side [two-run technique] on plates 4 to 25 mm thick and for multi-pass welding up to 40 mm).

3.3 Basic approval may be extended to include any welding process approvals on the basis of welding procedure tests as set out in Section 4 (see also F.); in exceptional cases, however, limited approval may also only be granted (in conjunction with a works inspection) for a specific material and/or welding process.

4. Welding staff (welders and supervisors) must meet the requirements set out in Section 2, B.2. and B.3. and be recognized by TL. For welder's qualification tests see Section 3.

### C. Quality Inspection, Responsibility

1. Welding shops shall ensure by means of regular in-house quality inspections during fabrication and on completion of the welding work that this work has been performed competently and satisfactorily (see Section 1, F.). For the duties and responsibilities of the welding supervisor, see also ISO 14731.

2. The welding shops are responsible for ensuring that the welding work conforms to these Rules, the approved manufacturing documents, any conditions stipulated in the approval documents, good machinery building practice and the latest state of welding practice. The inspections and checks to be performed by TL Surveyor do not relieve the welding shops of this responsibility.

3. With regard to quality inspections and the responsibilities involved in awarding subcontracts to independent branches or suppliers or to approved or non-approved outside firms working in the welding shop (subcontractors), see Section 1, F.; the "prime contractor" shall ensure that "subcontractors" also meet the conditions specified in 1.

4. Where non-approved outside firms and temporary staff are employed in the welding shop, the welding shop is responsible for carrying out quality inspections and for compliance with the conditions stated in para. 1. Subcontracting of work or the employment of temporary staff shall be notified to TL.

5. The scope of the required quality inspections depends on the construction project in question. It is essential to ensure, however, that the intended materials, welding consumables and auxiliary materials are used and that the weld preparation, assembly, execution of welding work and the dimensional accuracy and completeness of the welded joints meets the requirements stated in 2. For non-destructive testing of the welded joints, see I.

6. Following inspection and, if necessary, repair by the welding shop, the components shall be presented to TL's Surveyor for checking at suitable stages of fabrication. For this purpose they shall be readily accessible and shall normally be uncoated. Where the previous inspection has been inadequate, the Surveyor may reject components and require that they be presented again after satisfactory workshop inspection and any necessary repair work has been performed.

7. If the quality or good working order of a component cannot be guaranteed or is in doubt due to

inadequate or missing information in the manufacturing documents (e.g. production drawings), **TL** may demand appropriate improvements. This applies in analogous manner to supplementary or additional measures, even if these measures were not stipulated when the drawings were scrutinized or could not be stipulated due to insufficiently detailed representation in the production documents.

8. Responsibility for the proper performance of quality inspections and compliance with the conditions stated above lies with the welding shop. The inspections and checks to be performed by **TL**'s Surveyor do not relieve the welding shops from this responsibility.

9. **TL** is not responsible for guaranteeing that all the components and welded joints inspected to the prescribed extent (generally on a random basis) by its surveyors have been fabricated in accordance with the conditions and meet the requirements in every respect. Components or welded joints which subsequently turn out to be defective may be rejected or their repair may be demanded even if acceptance testing has already been carried out.

#### **D. Materials, Weldability**

1. Welded structures may only be fabricated using base materials of proven weldability. Materials must comply with Chapter 2, Materials. Other comparable materials (e.g. structural steels conforming to the standards) may only be used after **TL** has given its approval in each individual case.

2. Any conditions relating to working and welding imposed by the approval certificate and the recommendations of the material producer shall be complied with. For the selection of materials for the ship's hull, see the Chapter 1, Hull, Section 3,A Material, and in other rules and regulations issued by **TL** for specific ranges of application.

3. Steel castings and forgings shall comply with the Chapter 2, Materials and shall have been tested by **TL**. The carbon content of components made from carbon and carbon-manganese steels or cast steels

for welded structures shall not exceed 0,23 % C at ladle analysis (check analysis: max. 0,25 % C).

#### **E. Welding Consumables and Auxiliary Materials**

1. All the welding consumables and auxiliary materials used (e.g. covered electrodes, wire-gas combinations, wire-flux combinations, etc.) must have been approved by **TL** in accordance with Section 5. The quality grade required depends on the base materials to be welded and is shown in the relevant tables in Section 5.

2. The welding consumables must enable a welded joint to be made which is appropriate to the base material and the type of stress to which it is subjected and also enable trouble-free further processing. For joints between dissimilar materials (with the exception of high-alloy, austenitic steels), the welding consumable should, wherever possible, be geared to the lower alloyed material or the material with the lower strength.

3. For welding very thick-walled, rigid components (approx. 30 mm and over) and welding of forgings and castings, hydrogen-controlled welding consumables and auxiliary materials shall be used wherever possible, e.g. those of quality grade ... H15(H) or lower or ...Y.. H10 (HH) or lower for higher-strength structural steels.

4. Hydrogen-controlled welding consumables and auxiliary materials should also be used for components which are subjected to full load immediately after welding (e.g. lifting lugs or as a result of pressure tests) or where allowance has to be made for a high degree of residual stress due to the rigidity of the structure and, where applicable, a high yield strength or strength of a structure.

#### **F. Welding procedure tests**

##### **1. General**

1.1 Only welding procedures whose suitability

for the application in question is evident from general experience or has been verified by means of a welding procedure test in accordance with Section 4 and the following provisions may be used. Table 4.1 in Section 4 gives a list of the requisite verifications. The welding procedure must have been approved by TL for the welding shop in question as part of the welding shop approval (see also B.).

**1.2** Welding procedure tests supervised by TL verification of satisfactory operational handling and a trouble-free execution of the procedure, and also adequate quality properties for the welded joints made under production conditions at the user's works are in general required for all materials and welding processes other than those covered by the (basic) approval as described in B.3.1.

**1.3** For conventional single-wire submerged-arc butt welding processes using solid wire electrodes for welding normal-strength structural steels, comparable forged steels and cast steels from both sides, proof prior to initial use of the reliability and technical suitability of the method by means of trial welds and non-destructive (e.g. radiographic) tests as directed by the Surveyor is sufficient. The welding consumables and auxiliary materials used must have been approved by TL.

**1.4** TL may additionally require welding procedure tests for specific (difficult) component shapes or combinations of materials, particular weld shapes, process variants or combinations, and also for particular welding consumables and auxiliary materials. The same applies in analogous manner to other joining processes or (surface) finishing operations such as thermal cutting or flame straightening.

**1.5** The information in the preceding and following items, especially the information on test pieces, specimen shapes, tests and requirements, applies to the normal materials, welding processes and weld shapes in current use in ship-machine building, the behaviour of which under service conditions has been verified by experience and/or test results. In cases of doubt, TL may call for additional and/or different test pieces, specimen shapes or tests to verify satisfactory suitability for use.

**1.6** In the case of welding processes whose characteristics result in weld shapes other than those verified by experience and/or test results (e.g. those with a considerable notch effect), the influence of the weld shape on the fatigue strength behaviour of the welded joints may be investigated in addition to carrying out the prescribed tests. The same applies in analogous manner to other characteristics of the welded joints, e.g. corrosion resistance.

## **2. Scope of Tests, Test Schedule, Limits of Application**

### **2.1 Test schedule, test details**

**2.1.1** The scope of the welding procedure tests (materials, test pieces, heat treatment, specimens, tests, etc.) shall be laid down in a test schedule to be submitted for approval in good time prior to testing, in accordance with Section 4, B.1. Depending on the nature and application of a welding process, the process details stipulated in Section 4, B.1.1 shall be specified and taken into account in the tests.

**2.1.2** Where no further details on the welding procedure tests are given in the following items, the provisions of Section 4 shall apply. The standards of the series EN ISO 15607-15614 may be applied, however TL reserve the right to set supplementary or different requirements above and beyond the provisions stated in the following items, e.g. for the scope of application (materials, weld types, welding positions, see 2.1.3).

**2.1.3** For welding procedure tests for the welding of (steel) machinery components, the provisions set out in Section 12, F. relating to the welding procedure tests for (hull) structural steels shall apply in analogous manner. This shall also particularly apply with regard to weld types and welding positions. Accordingly, both butt and fillet welds (or other particular weld forms) are also covered in the welding procedure tests, as are all the welding positions encountered.

**2.1.4** Welding procedure tests for the (repair) welding of propellers shall be performed in accordance with the provisions applicable to "production welds" in the Chapter 2, Materials issued by TL. These

must also be complied with for the welding consumables and heat treatment recommended and also the areas where welding is not permitted.

**2.1.5** For special welding processes, such as flash butt welding, friction welding, electron-beam or laser welding and also for special applications such as build-up welding on shafts, pistons or valves, the type and scope (form and dimensions of the test pieces) of the welding procedure tests and their scope in accordance with the foregoing provisions are specified separately in each individual case.

### **3. Test Pieces, Fabrication (Welding), (Post-Weld) Heat Treatment**

**3.1** For (steel) machinery components welding shall be performed on butt and fillet weld test pieces (where these are encountered in the production process) in analogous manner to Section 12, F.3. or, by agreement with **TL**, in accordance with the standards of the series EN ISO 15607-15614. Test pieces for other components, particular welding processes or applications shall be agreed with **TL** in each individual case.

**3.2** The direction of rolling of butt and fillet weld test pieces shall generally be parallel to the direction of the weld. The weld shapes shall correspond to those used in the fabrication process.

**3.3** For welding, the test pieces shall be made from materials whose properties may be unequivocally proved in accordance with the requirements specified in the Chapter 2, Materials or approved material specifications by the submission of certificates and by marking the material (stamping). In cases of doubt, **TL** may call for appropriate material examinations to be carried out. See Section 4, B.3.

**3.4** The welding parameters stipulated in the preliminary welding procedure specification (pWPS) shall be prepared and it is necessary to record the parameters used in the tests and specify these in the final welding procedure specification. See Section 4, B.5.

**3.5** Pre-treatment and after-treatment of the test pieces by preheating, heat treatment or the like is only permitted if stipulated for these materials during actual fabrication. This treatment shall also be recorded and specified in the final welding procedure specification. See Section 4, B.6.

### **4. Non-Destructive Tests**

Prior to sectioning, the test pieces shall undergo comprehensive non-destructive tests to detect welding defects or defects in the welding procedure. The test method or methods (a combination) to be applied are determined by the nature of the test piece or weld and shall be agreed with **TL** and stipulated in the test schedule. See Section 4, B.7.

### **5. Sectioning of Test Pieces, Type and Number of Specimens**

**5.1** The sectioning of test pieces and the preparation of specimens is subject to the provisions of Chapter 1, Section 4, B.8.

**5.2** Unless otherwise agreed in a particular case, one set of butt weld specimens shall comprise the following specimens. The specimen shapes and dimensions shall conform to the provisions of the standards or Section 11 as applicable:

- 2 transverse tensile test specimens in accordance with ISO 4136 (for larger plate thicknesses a correspondingly greater number of specimens shall be provided to cover the full cross-section),
- 1 round tensile test specimen by analogy to the provisions of Section 5, B.2.3 (Fig. 16.1 and 16.2) taken lengthwise from the weld metal if welding consumables and auxiliary materials not approved by **TL** are to be used (see Section 4, B.3.2),

if different materials are to be joined, if welds are made using dissimilar welding consumables or if the characteristics of the welding process suggest that the weld metal itself is likely to be considerably affected.



A round tensile test specimen is to be prepared in every case (except for aluminium alloys) where the mechanical properties of the weld metal are inferior to those of the base material (e.g. when welding high-strength steels). The diameter "d0" of the specimen shall be as large as possible (but not more than 10 mm) and the gauge length "L0" shall be  $5 \times d0$ . The provisions of Section 5, B.2. are to be applied in analogous manner. For plate thicknesses  $\leq 20$  mm the TL may dispense with the round tensile specimen.

- 4 transverse bend test specimens, in accordance with ISO 5173 half to be bent with the final pass in tension (FBB) and half with the root pass in tension (RBB),

or

- 2 transverse bend test specimens (1FBB and 1RBB) as before and

2 side bend test specimens taken at right angles to the butt weld (SBB) in accordance with ISO 5173 in the case of test pieces over 12 mm thick, or

- 4 side bend test specimens (SBB) in the case of test pieces more than 20 mm thick and welding processes liable to give rise to segregations, solidification cracking, lack of fusion or similar defects inside the weld (e.g. single-side and vertical-down welding)

**Note:**

*In the case of pairs of materials which differ in strength, it may be advisable to use butt-welded longitudinal bend test specimens (FBB and RBB) in accordance with ISO 5173 with the weld seam in the centre of the specimen instead of butt-welded transverse bend test specimens. See also Section 11. The details of this test and the requirements (as a rule a qualitative assessment of the bending behaviour) shall be agreed on a case-by-case basis.*

- 3 notched bar impact test specimens each (Charpy V-notch specimens with the notch perpendicular to the surface of the plate)

in accordance with ISO 9016, from the centre of the weld (VWT 0/1), from the fusion boundary/transition zone (VHT 0/1) and from the heat-affected zone (VHT 2/1), taken from the last side welded. Where plate and castings are to be united, the notched bar impact test specimens shall be taken from the fusion boundary/transition zone and heat affected zone of both materials. With very large plate thicknesses, notched bar impact test specimens shall be taken from the surface and back of the weld and in the case of welding processes liable to cause segregation in the central zone, an additional 3 notched bar impact test specimens of each type shall be taken from the same areas in middle of the plate thickness.

The dimension "a" (see ISO 9016) shall be such that the point of intersection of the centre line of the specimen and the middle of the notch lies in the coarse-grained area of the heat-affected zone. This dimension may be generally taken as 2 mm. Where welding procedure tests are performed on steels tough at subzero temperatures, test specimens with notches located at  $a = 1$  mm,  $a = 3$  mm and  $a = 5$  mm shall be prepared, unless otherwise specified in an individual case.

Depending on the base material and welding process concerned, further notched bar impact test specimens from other areas may be stipulated. Notched bar impact test specimens may be partly or wholly dispensed with where the results of these tests in connection with the use of a particular welding process are of minor significance for certain materials, e.g.

austenitic stainless steels or aluminium alloys (except for low-temperature applications).

- 2 macrographic specimens for evaluating the grain structure and if necessary (e.g. for alloy steels) micrographic specimens.
- Hardness tests (Vickers HV5 or HV10) in accordance with EN ISO 9015-1 (EN ISO

9015-2 in the case of laser welding) shall be carried out where, having regard to the base material and the welding process, the possibility cannot be discounted that preheating and/or the heat flow during welding may affect the hardness values in such a way as to impair the toughness or strength characteristics of the weld. Hardness measurements shall always be performed on higher-strength structural steels and on high-strength (quenched and tempered) fine-grained structural steels with minimum yield strengths of more than 355 N/mm<sup>2</sup>.

- Weld metal analysis, if necessary and if agreed with TL.

**5.3** Two or more macrographic specimens, as applicable depending on the length of the test piece, shall be taken from the simplified (T-jointed) filletwelded test pieces in accordance with EN ISO 15607-15614 to evaluate the penetration conditions, any irregularities in the welded joints and the grain structure. If necessary, hardness measurements as described in EN ISO 9015-1 and 9015-2 shall be performed (see 5.2) and (in the case of alloy steels) micrographic specimens taken. The remainder of the test pieces is to be divided into convenient portions which, after removal of one of the welds, are to be broken open on alternate sides for evaluation of the fracture (see ISO 9017).

**5.4** A set of double T-joint (cruciform) fillet weld test specimens according to Fig. 16.1 shall comprise the following specimens. The specimen shapes and dimensions shall conform to the provisions of, Section 11:

- 3 cruciform tensile test specimens (Z) as shown in Fig. 16.2 for determining the tensile- shear strength of the weld metal
- 2 macrographic specimens (M) for evaluating the penetration conditions, any irregularities in the welded joints and the grain structure. If necessary, hardness measurements (see 5.2) shall be performed

in accordance with EN ISO 9015-1 and 9015-2. Where necessary (e.g. in the case of alloy steels), micrographic specimens.

The remainder of the test pieces is to be divided into convenient portions which, after removal of one of the welds, are to be broken open on alternate sides for evaluation of the fracture (see EN 1320).

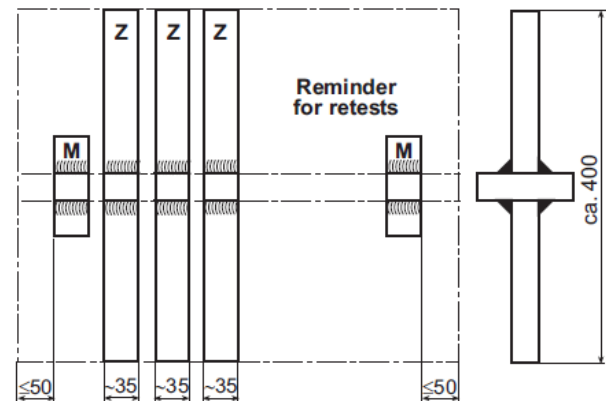

**Fig. 16.1 Set of double T-joint (cruciform) specimens**

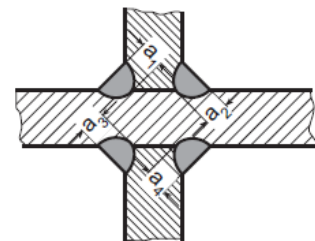

$$a_1 + a_2 = \text{fracture section } S_{1/2}$$

$$a_3 + a_4 = \text{fracture section } S_{3/4}$$

$$\text{Tensile-shear strength} = \frac{\text{Breaking load } F}{S_B \cdot \text{width of specimen}} \quad [\text{N/mm}^2]$$

$$S_B = S_{1/2} \text{ or } S_{3/4} \text{ according to position of fracture}$$

**Fig. 16.2 Cruciform tensile test specimen, weld cross-section**

**5.5** The specimens and tests for particular components, materials, welding processes and/or their uses (see 2.1.5) will be specified separately in accordance with the foregoing provisions in each individual case.

Table 16.1 Requirements applicable to the testing of welded joints (1)

Type of test	Requirements		
Tensile test transversely to weld	Tensile strength as stipulated for the base material or in the assessment of suitability for the welding consumable		
Tensile test on a specimen of the weld metal	Yield strength or 0,2 % proof stress. Tensile strength and elongation as for the base material or as specified in the assessment of suitability for the welding consumable.		
Notched bar impact test on ISO-V-notch specimens taken from the centre of the weld	As specified for the base material in transverse direction or as specified in the assessment of suitability for the welding consumable. When using ferritic-austenitic, austenitic and nickel- base alloy welding consumables, $\geq 40$ J (2)		
Notched bar impact test on ISO-V-notch specimens taken from the weld transition zone	70 % of the required value for the base material in transverse direction, but at least 20 J (2)		
Technological bend test	<b>Bending angle</b> Degrees	<b>Strength category</b>	<b>Bending mandrel dia.</b>
	180° (3)	Ferritic steels with min. tensile strength $< 430$ N/mm <sup>2</sup> min. tensile strength $\geq 430$ to $460$ N/mm <sup>2</sup>	2 × a 2,5 × a
	180° (3)	Austenitic stainless steels and austenitic steels tough at subzero temperatures Ferritic steels with a minimum tensile strength $\geq 460$ N/mm <sup>2</sup>	2 × a 3 × a
	If a bending angle of 180 degrees is not attained, the following applies:		
	$\geq 90^\circ$ or $< 90^\circ$	Elongation ( $L_0$ = width of weld + wall thickness, symmetrical to weld) $\geq$ minimum elongation $A_5$ of base material Elongation over width of weld $> 30$ % (4) and faultless appearance of	
Metallographic examination	The macrographic specimen of the welded joint must reveal a satisfactory weld build-up and full penetration of the weld.		
	Micrographic specimens are to be examined for cracks. Only hot cracks are acceptable, and then only if they are few in number and widely scattered and agreement has been reached with the Surveyor as to their acceptability with regard to the materials and the range of application		
Hardness testing	The hardness in the heat-affected zones shall not exceed 350 HV 10. Hardness peaks in excess of this figure in narrow transition zones shall not give rise to complaints if the outcome of the technological test meets the requirements		
<p>1) Where special welding processes are used as described in 2.1.5, the values shall be agreed with TL.</p> <p>2) Only one impact energy value may be lower than the minimum mean value, and only by max. 30 %.</p> <p>3) The 180-degree requirement is deemed to have been met if the bend test was performed according to ISO 5173 and pressure was applied by the supports without cracks appearing.</p> <p>4) For steels welded with dissimilar consumables, different values may be agreed with TL.</p>			

## 6. Mechanical and Technological Tests, Requirements

6.1 The mechanical and technological tests shall be performed according to the provisions of Section 11 or to the standards stipulated therein. For retests, see Section 4, C.2.

6.2 The results of the mechanical and technological tests must satisfy the requirements stated in Table 16.1. TL may stipulate different or supplementary requirements especially for the specimens and tests described in 2.1.5 and 5.5.

## G. Design, Welding Technique

1. The general design principles described in Section 7 shall be observed. With regard to design and dimensioning (particularly that of (steel) machinery components in accordance with A.1.1), TL may call for application, in analogous manner, of the provisions Section 12, G.

2. Butt welds which are critical to the strength of the component must be executed as full-penetration welds. This category includes, for example, the butt welds joining the web and flange plates of engine bedplates and the butt welds uniting bearing brackets and connecting plates.

3. The fillet welds of load-bearing members, e.g. the neck seams of plate girders for uniting flange and web plates, must be capable of being welded without a break. For this purpose, the stiffeners or web plates are either to be added on close to the neck seams at a later date or adequate welding apertures are to be provided.

4. Components shall be designed so as to avoid seam intersections wherever possible. Individual components of complicated shape which, if welded, would result in a clustering of weld seams, e.g. bearing brackets, should either be cast in steel or, if welded, should undergo stress relief heat treatment. See H.

5. All parts to be joined by welding have to be carefully aligned and mounted and tacked in such a way that welding can be carried out with a minimum of distortion and residual stress. Wherever possible, welding should be performed in the downhand position.

6. Wherever possible, stiffening plates and web plates which are open at the ends are to be cut off at the ends as shown in Fig. 16.3 (corresponding to the thickness of the weld) at an angle of  $90^\circ$  to the mounting plane and welded round at the ends.

7. Castings and forgings that are to be joined to thin-walled components shall be provided with welding flanges which have been cast or forged on. Before welding, the welding edges of castings and forgings must be metallically clean and bright and must have been inspected for material defects using a suitable process.

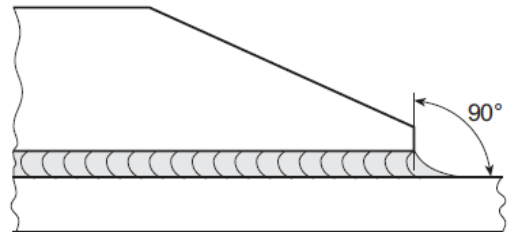

**Fig. 16.3** Welding round of stiffening plates or web plates

8. Tack welds which are to be left in place as part of the seam are subject to the same qualitative requirements as root passes. Defective tack welds may not be welded over. They are to be removed.

9. If the thickness of flange plates or web plates changes at butt joints, to give a better transition to the thicker section the edges which stand proud by more than 10 mm shall be bevelled off with a gradient of 1:1 or shallower, as shown in Fig. 16.4. Differences in thickness less than 10 mm may be compensated for in the weld.

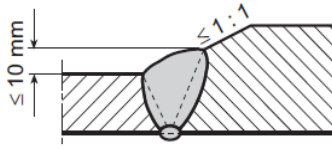

a) Butt joint in flange plate

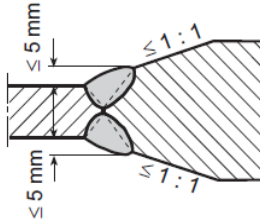

b) Butt joint in web plate

**Fig. 16.4 Butt-welded joints in plates of different thickness**

Where the loading transversely to the weld is predominantly dynamic, the transitions are to be made shallower and in this case the provisions of Section 12, G.3. shall be applied in analogous manner.

**10.** Welding may be performed in areas of components where cold forming has been carried out, including the adjoining surfaces over a width of 5 times the plate thickness  $t$ , provided that the conditions (bending radii) specified in Section 12, G.8. are met. Where components subjected to cold forming undergo normalizing heat treatment prior to welding, these conditions need not be adhered to.

**11.** Where approved by TL allowing for the relevant load conditions, build-up welds on machinery components subject to dynamic loads (e.g. shafts) shall be executed in a circumferential direction using a fully-mechanized welding process. The provisions of Section 12, G.9. shall apply in analogous manner.

## H. Post-Weld Heat Treatment

**1.** Thick-walled, rigid components or those of complicated design which exhibit high levels of residual stress after joining must be heat-treated after welding in accordance with the relevant standards or TL's approval

document. Examples are bedplates for diesel engines, gear boxes and welded gear wheels. See also G.4.

**Note:**

*Post-weld heat treatment (stress-relief heat treatment) may be advisable whenever components have, subsequently, to undergo machining and where therefore there is a risk of stresses being produced during the machining process leading to distortion of the components.*

**2.** The heat treatment generally takes the form of stress relief heat treatment. Depending on the material, however, annealing heat treatment or quenching and tempering may also be advisable or necessary. "Black to white" joints between unalloyed steels and austenitic stainless steels may not be subjected to a post-weld heat treatment. For the type and performance of the heat treatment, see Section 9.

## I. Inspection of Welded Components

**1.** The manufacturer shall present the components for the required intermediate and final inspections, (see also Section 1, F.1. and G.) in which the following shall be demonstrated to TL Surveyor:

- Proper weld preparation and execution of welding work,
- The satisfactory external condition of the components and especially of the welds,
- Use of the prescribed materials and dimensions by presentation of the documents relating to materials,
- The existence of relevant, valid welder's qualification and welding procedure tests covering the range of application,
- The proper performance of heat treatments by presentation of the relevant records and/or certificates,
- Compliance with the specified dimensions and tolerances by presentation of the records of dimensional data.

2. The following components shall be subjected to non-destructive testing in every case. TL Surveyor may also demand additional tests, as follows:

- Welded wheel bodies:

Ultrasonic and/or radiographic inspections together with surface crack inspections of the scope specified when the drawing was approved.

- Engine bedplates:

Surface crack inspection and random ultrasonic tests applied to the transverse girder welds, especially those of the bearing brackets.

- Other components:

Testing of the scope specified when the drawings were approved or when individual approval was granted.

Annex A - Comparison of Equivalent,  
Internationally Recognized Film System Classes

**ANNEX A**

**Comparison of Equivalent, Internationally Recognized Film System Classes**

Manufacturer / Film type	ASTM (1)	DIN (3)	EN (3)	ISO (2)	RCC-M(4)
<b>AGFA (5)</b>					
Structurix D2	special	G1	C1	GI	1
Structurix D3	1	G1	C2	GI	1
Structurix D3s.c.	1	G1	C2	GI	2
Structurix D4	1	G2	C3	GI	3
Structurix D5	1	G2	C4	GII	3-4
Structurix D7	2	G3	C5	GIII	4
Structurix D8	2	G4	C6	GIII	5
<b>Fuji (5)</b>					
IX 25	1	G2	C3	GI	3
IX 50	special	G1	C1	GI	1
IX 80	1	G2	C3	GI	3
IX 100	1	G2	C4	GII	3-4
IX 150	2	G4	6	GII	4-5
<b>Kodak (5)</b>					
DR	special	G1	C1	GI	
M	1	G1	C2	GI	
MX125	1	G2	C3	GI	
T200	1	G2	C4	GII	
AA400	2	G3	C5	GIII	
CX	3	G4	C6	GIII	
B	W-B			GIII	
<p><b>(1)</b> ASTM E 94-04  <b>(2)</b> ISO 5579  <b>(3)</b> Classification in accordance with EN ISO 11699-1.  <b>(4)</b> French standard.  <b>(5)</b> Provided that the appropriate proof of suitability is furnished, equivalent film types produced by other film manufacturers may also be considered.</p>					

**ANNEX B**

**Welding Positions**

**1. Welding positions according to ISO Standard**

**1.1 Butt Welds for Plates**

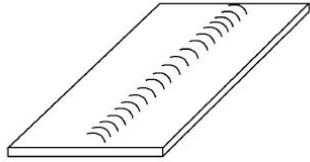

PA Flat

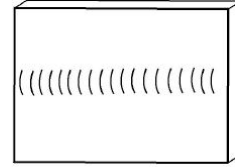

PC Horizontal Vertical

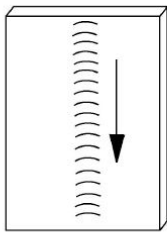

PG Vertical (downwards)

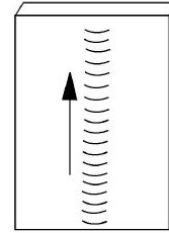

PF Vertical (upwards)

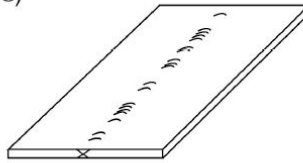

PO Overhand

**1.2 Fillet Welds for Plates**

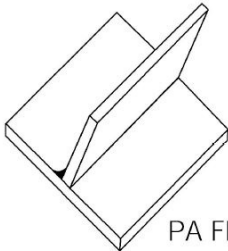

PA Flat

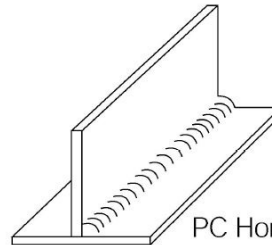

PC Horizontal Vertical

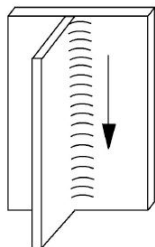

PG Vertical (downwards)

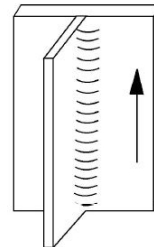

PF Vertical (upwards)



PO Overhand



2. Welding positions according to AWS-Code

2.1 Butt Weld for Plates

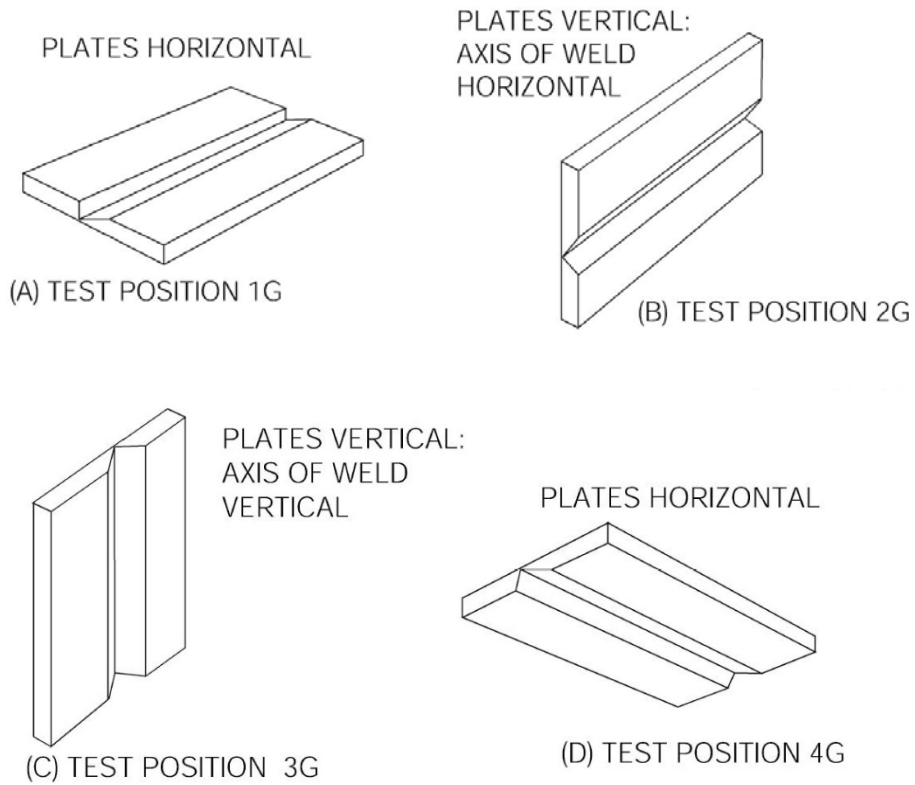

2.2 Fillet Welds for Plates

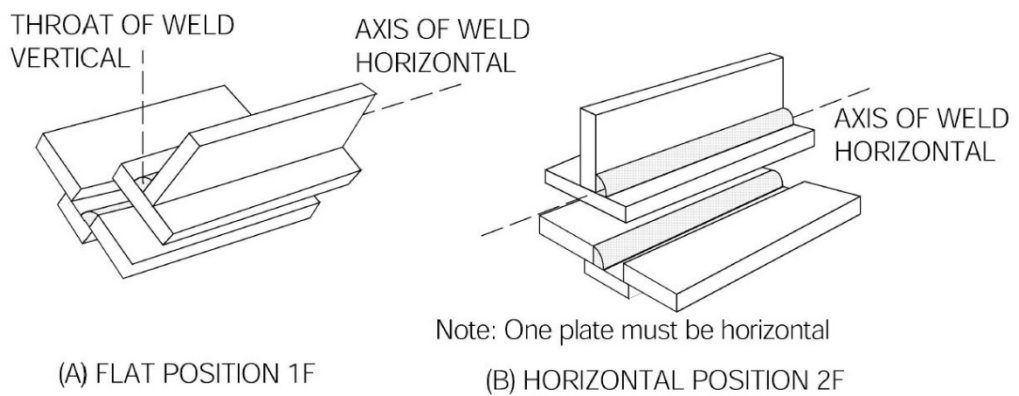

AXIS OF WELD VERTICAL

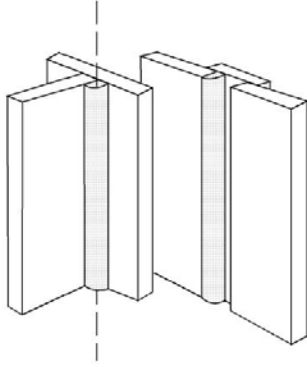

(C) VERTICAL POSITION 3F

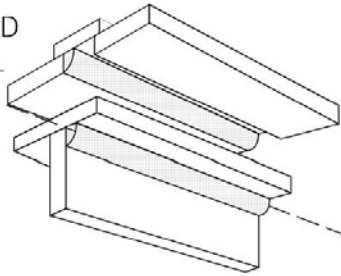
AXIS OF WELD  
HORIZONTAL

Note: One plate must be horizontal

(D) OVERHEAD POSITION 4F