

# M44 Documents for the approval of diesel engines

(1982)

(Rev.1

1983)

(Rev.2

1984)

(Rev.3

1986)

(Rev.4

1989)

(Rev.5

1992)

(Rev.6

Nov

2003)

(Rev.7

May

2004)

(Rev.8

Mar

2015

Complete

Revision)

## 1. Scope

The documents necessary to approve a diesel engine design for conformance to the Rules and for use during manufacture and installation are listed. The document flow between engine designer, Classification Society approval centre, engine builder/licensee and Classification Society's Surveyors is provided.

## 2. Definitions

Definitions relating to approval of diesel engines are given in Appendix 1.

## 3. Overview

### 3.1 Approval process

#### 3.1.1 Type approval certificate

For each type of engine that is required to be approved, a type approval certificate is to be obtained by the engine designer. The process details for obtaining a type approval certificate are in Section 4. This process consists of the engine designer obtaining:

- drawing and specification approval,
- conformity of production,
- approval of type testing programme,
- type testing of engines,
- review of the obtained type testing results, and
- evaluation of the manufacturing arrangements,
- issue of a type approval certificate upon satisfactorily meeting the Rule requirements.

---

#### Notes:

1. The requirements of M44 Rev.8 are to be uniformly implemented by IACS Societies for engines; when an application for certification for an engine is dated on or after 1 July 2016.
2. The "date of application for certification of the engine" is the date of whatever document the Classification Society requires/accepts as an application or request for certification of an individual engine.

**M44**  
**(cont)****3.1.2 Engine certificate**

Each diesel engine manufactured for a shipboard application is to have an engine certificate. The certification process details for obtaining the engine certificate are in Section 5. This process consists of the engine builder/licensee obtaining design approval of the engine application specific documents, submitting a comparison list of the production drawings to the previously approved engine design drawings referenced in 3.1.1, forwarding the relevant production drawings and comparison list for the use of the Surveyors at the manufacturing plant and shipyard if necessary, engine testing and upon satisfactorily meeting the Rule requirements, the issuance of an engine certificate.

**3.2 Document flow for diesel engines****3.2.1 Document flow for obtaining a type approval certificate**

3.2.1.1 For the initial engine type, the engine designer prepares the documentation in accordance with requirements in Tables 1 and 2 and forwards to the Classification Society according to the agreed procedure for review.

3.2.1.2 Upon review and approval of the submitted documentation (evidence of approval), it is returned to the engine designer.

3.2.1.3 The engine designer arranges for a Surveyor to attend an engine type test and upon satisfactory testing the Classification Society issues a type approval certificate.

3.2.1.4 A representative document flow process for obtaining a type approval certificate is shown in Appendix 2, Figure 1.

**3.2.2 Document flow for engine certificate**

3.2.2.1 The engine type must have a type approval certificate. For the first engine of a type, the type approval process and the engine certification process (ECP) may be performed simultaneously.

3.2.2.2 Engines to be installed in specific applications may require the engine designer/licensor to modify the design or performance requirements. The modified drawings are forwarded by the engine designer to the engine builder/licensee to develop production documentation for use in the engine manufacture in accordance with Table 3.

3.2.2.3 The engine builder/licensee develops a comparison list of the production documentation to the documentation listed in Tables 1 and 2. An example comparison list is provided in Appendix 4. If there are differences in the technical content on the licensee's production drawings/documents compared to the corresponding licensor's drawings, the licensee must obtain agreement to such differences from the licensor using the template in Appendix 5.

If the designer acceptance is not confirmed, the engine is to be regarded as a different engine type and is to be subjected to the complete type approval process by the licensee.

3.2.2.4 The engine builder/licensee submits the comparison list and the production documentation to the Classification Society according to the agreed procedure for review/approval.

3.2.2.5 The Classification Society returns documentation to the engine builder/licensee with confirmation that the design has been approved. This documentation is intended to be used

**M44**  
**(cont)**

by the engine builder/licensee and their subcontractors and attending Surveyors. As the attending Surveyors may request the engine builder/licensee or their subcontractors to provide the actual documents indicated in the list, the documents are necessary to be prepared and available for the Surveyors.

3.2.2.6 The attending Surveyors, at the engine builder/licensee/subcontractors, will issue product certificates as necessary for components manufactured upon satisfactory inspections and tests.

3.2.2.7 The engine builder/licensee assembles the engine, tests the engine with a Surveyor present. An engine certificate is issued by the Surveyor upon satisfactory completion of assembly and tests.

3.2.2.8 A representative document flow process for obtaining an engine certificate is shown in Appendix 2, Figure 2.

### **3.3 Approval of diesel engine components**

Components of engine designer's design which are covered by the type approval certificate of the relevant engine type are regarded as approved whether manufactured by the engine manufacturer or sub-supplied. For components of subcontractor's design, necessary approvals are to be obtained by the relevant suppliers (e.g. exhaust gas turbochargers, charge air coolers, etc.).

### **3.4 Submission format of documentation**

The Classification Society determines the documentation format: electronic or paper. If documentation is to be submitted in paper format, the number of copies is determined by each Society.

## **4. Type approval process**

The type approval process consists of the steps in 4.1 to 4.4. The document flow for this process is shown in Appendix 2, Figure 1.

The documentation, as far as applicable to the type of engine, to be submitted by the engine designer/licensor to the Classification Society is listed in Tables 1 and 2.

### **4.1 Documents for information Table 1**

Table 1 lists basic descriptive information to provide the Classification Society an overview of the engine's design, engine characteristics and performance. Additionally, there are requirements related to auxiliary systems for the engine's design including installation arrangements, list of capacities, technical specifications and requirements, along with information needed for maintenance and operation of the engine.

### **4.2 Documents for approval or recalculation Table 2**

Table 2 lists the documents and drawings, which are to be approved by the Classification Society.

### **4.3 Design approval/appraisal (DA)**

DA's are valid as long as no substantial modifications have been implemented. Where substantial modifications have been made the validity of the DA's may be renewed based on

**M44**  
(cont)

evidence that the design is in conformance with all current Rules and statutory regulations (e.g. SOLAS, MARPOL). See also 4.6.

**4.4 Type approval test**

A type approval test is to be carried out in accordance with IACS UR M71 and is to be witnessed by the Classification Society.

The manufacturing facility of the engine presented for the type approval test is to be assessed in accordance with IACS UR M72.

**4.5 Type approval certificate**

After the requirements in M44.4.1 through M44.4.4 have been satisfactorily completed the Classification Society issues a type approval certificate (TAC).

**4.6 Design modifications**

After the Classification Society has approved the engine type for the first time, only those documents as listed in the tables, which have undergone substantive changes, will have to be resubmitted for consideration by the Classification Society.

**4.7 Type approval certificate renewals**

A renewal of type approval certificates will be granted upon:

4.7.1 Submission of information in either 4.7.1.1 or 4.7.1.2.

4.7.1.1 The submission of modified documents or new documents with substantial modifications replacing former documents compared to the previous submission(s) for DA.

4.7.1.2 A declaration that no substantial modifications have been applied since the last DA issued.

**4.8 Validity of type approval certificate**

The Classification Society reserves the right to limit the duration of validity of the type approval certificate. The type approval certificate will be invalid if there are substantial modifications in the design, in the manufacturing or control processes or in the characteristics of the materials unless approved in advance by the Classification Society.

**4.9 Document review and approval**

4.9.1 The assignment of documents to Table 1 for information does not preclude possible comments by the individual Classification Society.

4.9.2 Where considered necessary, the Classification Society may request further documents to be submitted. This may include details or evidence of existing type approval or proposals for a type testing programme in accordance with UR M71.

**5. Certification process**

The certification process consists of the steps in 5.1 to 5.5. This process is illustrated in Appendix 2, Figure 2 showing the document flows between the:

**M44**  
**(cont)**

- engine designer/licensor,
- engine builder/licensee,
- component manufacturers,
- Classification Society approval centre, and
- Classification Society site offices.

For those cases when a licensor – licensee agreement does NOT apply, an “engine designer” shall be understood as the entity that has the design rights for the engine type or is delegated by the entity having the design rights to modify the design.

The documents listed in Table 3 may be submitted by:

- the engine designer (licensor),
- the manufacturer/licensee.

**5.1 Document development for production**

Prior to the start of the engine certification process, a design approval is to be obtained per 4.1 through 4.3 for each type of engine. Each type of engine is to be provided with a type approval certificate obtained by the engine designer/licensor prior to the engine builder/licensee beginning production manufacturing. For the first engine of a type, the type approval process and the certification process may be performed simultaneously.

The engine designer/licensor reviews the documents listed in Tables 1 and 2 for the application and develops, if necessary, application specific documentation for the use of the engine builder/licensee in developing engine specific production documents.

If substantive changes have been made, the affected documents are to be resubmitted to the Classification Society as per 4.6.

**5.2 Documents to be submitted for inspection and testing**

Table 3 lists the production documents, which are to be submitted by the engine builder/licensee to the Classification Society following acceptance by the engine designer/licensor. The Surveyor uses the information for inspection purposes during manufacture and testing of the engine and its components. See 3.2.2.3 through 3.2.2.6.

**5.3 Alternative execution**

If there are differences in the technical content on the licensee’s production drawings/documents compared to the corresponding licensor’s drawings, the licensee must provide to the Classification Society approval centre a “Confirmation of the licensor’s acceptance of licensee’s modifications” approved by the licensor and signed by licensee and licensor. Modifications applied by the licensee are to be provided with appropriate quality requirements. See Appendix 5 for a sample format.

**5.4 Manufacturer approval**

The Classification Society assesses conformity of production with the Classification Society’s requirements for production facilities comprising manufacturing facilities and processes,

**M44**  
(cont)

machining tools, quality assurance, testing facilities, etc. See IACS UR M72. Satisfactory conformance results in the issue of a class approval document.

**5.5 Document availability**

In addition to the documents listed in Table 3, the engine builder/licensee is to be able to provide to the Surveyor performing the inspection upon request the relevant detail drawings, production quality control specifications and acceptance criteria. These documents are for supplemental purposes to the survey only.

**5.6 Engine assembly and testing**

Each engine assembly and testing procedure required according to relevant IACS URs are to be witnessed by the Classification Society unless an Alternative Certification Scheme meeting the requirements of UR Z26 is agreed between manufacturer and the Society.

**M44**  
 (cont)

**Table 1 Documentation to be submitted for information, as applicable**

No.	Item
1	Engine particulars (e.g. Data sheet with general engine information (see Appendix 3), Project Guide, Marine Installation Manual)
2	Engine cross section
3	Engine longitudinal section
4	Bedplate and crankcase of cast design
5	Thrust bearing assembly <sup>1</sup>
6	Frame/framebox/gearbox of cast design <sup>2</sup>
7	Tie rod
8	Connecting rod
9	Connecting rod, assembly <sup>3</sup>
10	Crosshead, assembly <sup>3</sup>
11	Piston rod, assembly <sup>3</sup>
12	Piston, assembly <sup>3</sup>
13	Cylinder jacket/ block of cast design <sup>2</sup>
14	Cylinder cover, assembly <sup>3</sup>
15	Cylinder liner
16	Counterweights (if not integral with crankshaft), including fastening
17	Camshaft drive, assembly <sup>3</sup>
18	Flywheel
19	Fuel oil injection pump
20	Shielding and insulation of exhaust pipes and other parts of high temperature which may be impinged as a result of a fuel system failure, assembly
	For electronically controlled engines, construction and arrangement of:
21	Control valves
22	High-pressure pumps
23	Drive for high pressure pumps
24	Operation and service manuals <sup>4</sup>
25	FMEA (for engine control system) <sup>5</sup>
26	Production specifications for castings and welding (sequence)
27	Evidence of quality control system for engine design and in service maintenance
28	Quality requirements for engine production
29	Type approval certification for environmental tests, control components <sup>6</sup>

## FOOTNOTES:

1. If integral with engine and not integrated in the bedplate.
2. Only for one cylinder or one cylinder configuration.
3. Including identification (e.g. drawing number) of components.
4. Operation and service manuals are to contain maintenance requirements (servicing and repair) including details of any special tools and gauges that are to be used with their fitting/settings together with any test requirements on completion of maintenance.
5. Where engines rely on hydraulic, pneumatic or electronic control of fuel injection and/or valves, a failure mode and effects analysis (FMEA) is to be submitted to demonstrate that failure of the control system will not result in the operation of the engine being degraded beyond acceptable performance criteria for the engine. The FMEA reports required will not be explicitly approved by the Classification Society.
6. Tests are to demonstrate the ability of the control, protection and safety equipment to function as intended under the specified testing conditions per UR E10.

# M44

(cont)

**Table 2 Documentation to be submitted for approval, as applicable**

No.	Item
1	Bedplate and crankcase of welded design, with welding details and welding instructions <sup>1,2</sup>
2	Thrust bearing bedplate of welded design, with welding details and welding instructions <sup>1</sup>
3	Bedplate/oil sump welding drawings <sup>1</sup>
4	Frame/framebox/gearbox of welded design, with welding details and instructions <sup>1,2</sup>
5	Engine frames, welding drawings <sup>1,2</sup>
6	Crankshaft, details, each cylinder No.
7	Crankshaft, assembly, each cylinder No.
8	Crankshaft calculations (for each cylinder configuration) according to the attached data sheet and UR M53
9	Thrust shaft or intermediate shaft (if integral with engine)
10	Shaft coupling bolts
11	Material specifications of main parts with information on non-destructive material tests and pressure tests <sup>3</sup>
	Schematic layout or other equivalent documents on the engine of:
12	Starting air system
13	Fuel oil system
14	Lubricating oil system
15	Cooling water system
16	Hydraulic system
17	Hydraulic system (for valve lift)
18	Engine control and safety system
19	Shielding of high pressure fuel pipes, assembly <sup>4</sup>
20	Construction of accumulators (common rail) (for electronically controlled engine)
21	Construction of common accumulators (common rail) (for electronically controlled engine)
22	Arrangement and details of the crankcase explosion relief valve (see UR M9) <sup>5</sup>
23	Calculation results for crankcase explosion relief valves (see UR M9)
24	Details of the type test program and the type test report <sup>7</sup>
25	High pressure parts for fuel oil injection system <sup>6</sup>
26	Oil mist detection and/or alternative alarm arrangements (see UR M10)
27	Details of mechanical joints of piping systems (see UR P2)
28	Documentation verifying compliance with inclination limits (see UR M46)
29	Documents as required in UR E22, as applicable

FOOTNOTES:

1. For approval of materials and weld procedure specifications. The weld procedure specification is to include details of pre and post weld heat treatment, weld consumables and fit-up conditions.
2. For each cylinder for which dimensions and details differ.
3. For comparison with Society requirements for material, NDT and pressure testing as applicable.
4. All engines.
5. Only for engines of a cylinder diameter of 200 mm or more or a crankcase volume of 0.6 m<sup>3</sup> or more.
6. The documentation to contain specifications for pressures, pipe dimensions and materials.
7. The type test report may be submitted shortly after the conclusion of the type test.



# M44

(cont)

**Table 3 Documentation for the inspection of components and systems**

- Special consideration will be given to engines of identical design and application
- For engine applications refer to UR M72

No.	Item
1	Engine particulars as per data sheet in Appendix 3
2	Material specifications of main parts with information on non-destructive material tests and pressure tests <sup>1</sup>
3	Bedplate and crankcase of welded design, with welding details and welding instructions <sup>2</sup>
4	Thrust bearing bedplate of welded design, with welding details and welding instructions <sup>2</sup>
5	Frame/framebox/gearbox of welded design, with welding details and instructions <sup>2</sup>
6	Crankshaft, assembly and details
7	Thrust shaft or intermediate shaft (if integral with engine)
8	Shaft coupling bolts
9	Bolts and studs for main bearings
10	Bolts and studs for cylinder heads and exhaust valve (two stroke design)
11	Bolts and studs for connecting rods
12	Tie rods
	Schematic layout or other equivalent documents on the engine of: <sup>3</sup>
13	Starting air system
14	Fuel oil system
15	Lubricating oil system
16	Cooling water system
17	Hydraulic system
18	Hydraulic system (for valve lift)
19	Engine control and safety system
20	Shielding of high pressure fuel pipes, assembly <sup>4</sup>
21	Construction of accumulators for hydraulic oil and fuel oil
22	High pressure parts for fuel oil injection system <sup>5</sup>
23	Arrangement and details of the crankcase explosion relief valve (see UR M9) <sup>6</sup>
24	Oil mist detection and/or alternative alarm arrangements (see UR M10)
25	Cylinder head
26	Cylinder block, engine block
27	Cylinder liner
28	Counterweights (if not integral with crankshaft), including fastening
29	Connecting rod with cap
30	Crosshead
31	Piston rod
32	Piston, assembly <sup>7</sup>
33	Piston head
34	Camshaft drive, assembly <sup>7</sup>
35	Flywheel
36	Arrangement of foundation (for main engines only)
37	Fuel oil injection pump
38	Shielding and insulation of exhaust pipes and other parts of high temperature which may be impinged as a result of a fuel system failure, assembly
39	Construction and arrangement of dampers
	For electronically controlled engines, assembly drawings or arrangements of:
40	Control valves

**M44**  
 (cont)

No.	Item
41	High-pressure pumps
42	Drive for high pressure pumps
43	Valve bodies, if applicable
44	Operation and service manuals <sup>8</sup>
45	Test program resulting from FMEA (for engine control system) <sup>9</sup>
46	Production specifications for castings and welding (sequence)
47	Type approval certification for environmental tests, control components <sup>10</sup>
48	Quality requirements for engine production

## FOOTNOTES:

1. For comparison with Society requirements for material, NDT and pressure testing as applicable.
2. For approval of materials and weld procedure specifications. The weld procedure specification is to include details of pre and post weld heat treatment, weld consumables and fit-up conditions.
3. Details of the system so far as supplied by the engine manufacturer such as: main dimensions, operating media and maximum working pressures.
4. All engines.
5. The documentation to contain specifications for pressures, pipe dimensions and materials.
6. Only for engines of a cylinder diameter of 200 mm or more or a crankcase volume of 0.6 m<sup>3</sup> or more.
7. Including identification (e.g. drawing number) of components.
8. Operation and service manuals are to contain maintenance requirements (servicing and repair) including details of any special tools and gauges that are to be used with their fitting/settings together with any test requirements on completion of maintenance.
9. Required for engines that rely on hydraulic, pneumatic or electronic control of fuel injection and/or valves.
10. Documents modified for a specific application are to be submitted to the Classification Society for information or approval, as applicable. See 3.2.2.2, Appendix 4 and Appendix 5.

# M44

(cont)

## UR M44 - APPENDIX 1 - GLOSSARY

Term	Definition
Acceptance criteria	A set of values or criteria which a design, product, service or process is required to conform with, in order to be considered in compliance
Accepted	Status of a design, product, service or process, which has been found to conform to specific acceptance criteria
Alternative Certification Scheme (ACS)	<p>A system, by which a society evaluates a manufacturer's quality assurance and quality control arrangements for compliance with Rule requirements, then authorizes a manufacturer to undertake and witness testing normally required to be done in the presence of a Surveyor. The Alternative Certification Scheme as presently administrated by the Member Societies is generally known as:</p> <p>ABS: Product Quality Assurance            BV: Alternative Survey Scheme            CCS: Type Approval-A            CRS: Examination of the manufacturing process and quality assurance system            DNV-GL: Manufacturing Survey Arrangement            IRS: IRS Quality Assurance Scheme            KR: Quality Assurance System            LR: LR Quality Schemes            NK: Approval of Manufacturers            RINA: Alternative Survey Scheme            RS Agreement on Survey</p>
Appraisal	Evaluation by a competent body
Approval	The granting of permission for a design, product, service or process to be used for a stated purpose under specific conditions based upon a satisfactory appraisal
Assembly	Equipment or a system made up of components or parts
Assess	Determine the degree of conformity of a design, product, service, process, system or organization with identified specifications, Rules, standards or other normative documents
Audit	Planned systematic and independent examination to determine whether the activities are documented, the documented activities are implemented, and the results meet the stated objectives
Auditor	Individual who has the qualifications and experience to perform audits
Certificate	A formal document attesting to the compliance of a design, product, service or process with acceptance criteria
Certification	A procedure whereby a design, product, service or process is approved in accordance with acceptance criteria

**M44**  
 (cont)

Term	Definition
Class	Short for Classification Society
Class approval	Approved by a Classification Society
Classification	Specific type of certification, which relates to the Rules of the relevant Classification Society
Competent body	Organization recognized as having appropriate knowledge and expertise in a specific area
Component	Part, member of equipment or system
Conformity	Where a design, product, process or service demonstrates compliance with its specific requirements
Contract	Agreement between two or more parties relating to the scope of service
Contractor	see Supplier
Customer	Party who purchases or receives goods or services from another
Design	All relevant plans, documents, calculations described in the performance, installation and manufacturing of a product
Design analysis	Investigative methodology selectively used to assess the design
Design appraisal	Evaluation of all relevant plans, calculations and documents related to the design
Design review	Part of the appraisal process to evaluate specific aspects of the design
Drawings approval/ plan approval	Part of the design approval process which relates to the evaluation of drawings and plans
Equipment	Part of a system assembled from components
Equivalent	An acceptable, no less effective alternative to specified criteria
Evaluation	Systematic examination of the extent to which a design, product, service or process satisfies specific criteria
Examination	Assessment by a competent person to determine compliance with requirements
Inspection	Examination of a design, product service or process by an Inspector
Inspection plan	List of tasks of inspection to be performed by the Inspector

**M44**  
 (cont)

Term	Definition
Installation	The assembling and final placement of components, equipment and subsystems to permit operation of the system
Manufacturer	Party responsible for the manufacturing and quality of the product
Manufacturing process	Systematic series of actions directed towards manufacturing a product
Manufacturing process approval	Approval of the manufacturing process adopted by the manufacturer during production of a specific product
Material	Goods supplied by one manufacturer to another manufacturer that will require further forming or manufacturing before becoming a new product
Modification	A limited change that does not affect the current approval
Modification notice	Information about a design modification with new modification index or new drawing number replacing the earlier drawing
Performance test	Technical operation where a specific performance characteristic is determined
Producer	See manufacturer
Product	Result of the manufacturing process
Prototype test	Investigations on the first or one of the first new engines with regard to optimization, fine tuning of engine parameters and verification of the expected running behaviour
Quality assurance	All the planned and systematic activities implemented within the quality system, and demonstrated as needed to provide adequate confidence that an entity will fulfil requirements for quality. Refer to ISO 9000 series
Regulation	Rule or order issued by an executive authority or regulatory agency of a government and having the force of law
Repair	Restore to original or near original condition from the results of wear and tear or damages for a product or system in service
Requirement	Specified characteristics used for evaluation purposes
Information	Additional technical data or details supplementing the drawings requiring approval
Revision	Means to record changes in one or more particulars of design drawings or specifications
Specification	Technical data or particulars which are used to establish the suitability of materials, products, components or systems for their intended use

**M44**  
 (cont)

Term	Definition
Substantive modifications or major modifications or major changes	Design modifications, which lead to alterations in the stress levels, operational behaviour, fatigue life or an effect on other components or characteristics of importance such as emissions
Subsupplier/subcontractor	One who contracts to supply material to another supplier
Supplier	One who contracts to furnish materials or design, products, service or components to a customer or user
Test	A technical operation that consists of the determination of one or more characteristics or performance of a given product, material, equipment, organism, physical phenomenon, process or service according to a specified procedure. A technical operation to determine if one or more characteristic(s) or performance of a product, process or service satisfies specific requirements
Traceability	Ability to follow back through the design and manufacturing process to the origin
Type approval	<p>The establishment of the acceptability of a product through the systematic:</p> <ol style="list-style-type: none"> <li>1. Evaluation of a design to determine conformance with specifications</li> <li>2. Witnessing manufacture and testing of a type of product to determine compliance with the specification</li> <li>3. Evaluation of the manufacturing arrangements to confirm that the product can be consistently produced in accordance with the specification</li> </ol>
Type approval test	Last step of the type approval procedure. Test program in accordance with UR M71
Witness	Individual physically present at a test and being able to record and give evidence about its outcome

# M44

(cont)

## UR M44 - APPENDIX 2 - REPRESENTATIVE DOCUMENT FLOW DIAGRAMS

The document flow diagrams in this appendix are provided as an aid to all parties involved in the engine certification process as to their roles and responsibilities. Variations in the document flow may vary in response to unique issues with regard to various factors related to location, availability of components and surveys. In any case, the text in the UR takes precedence over these flow diagrams.

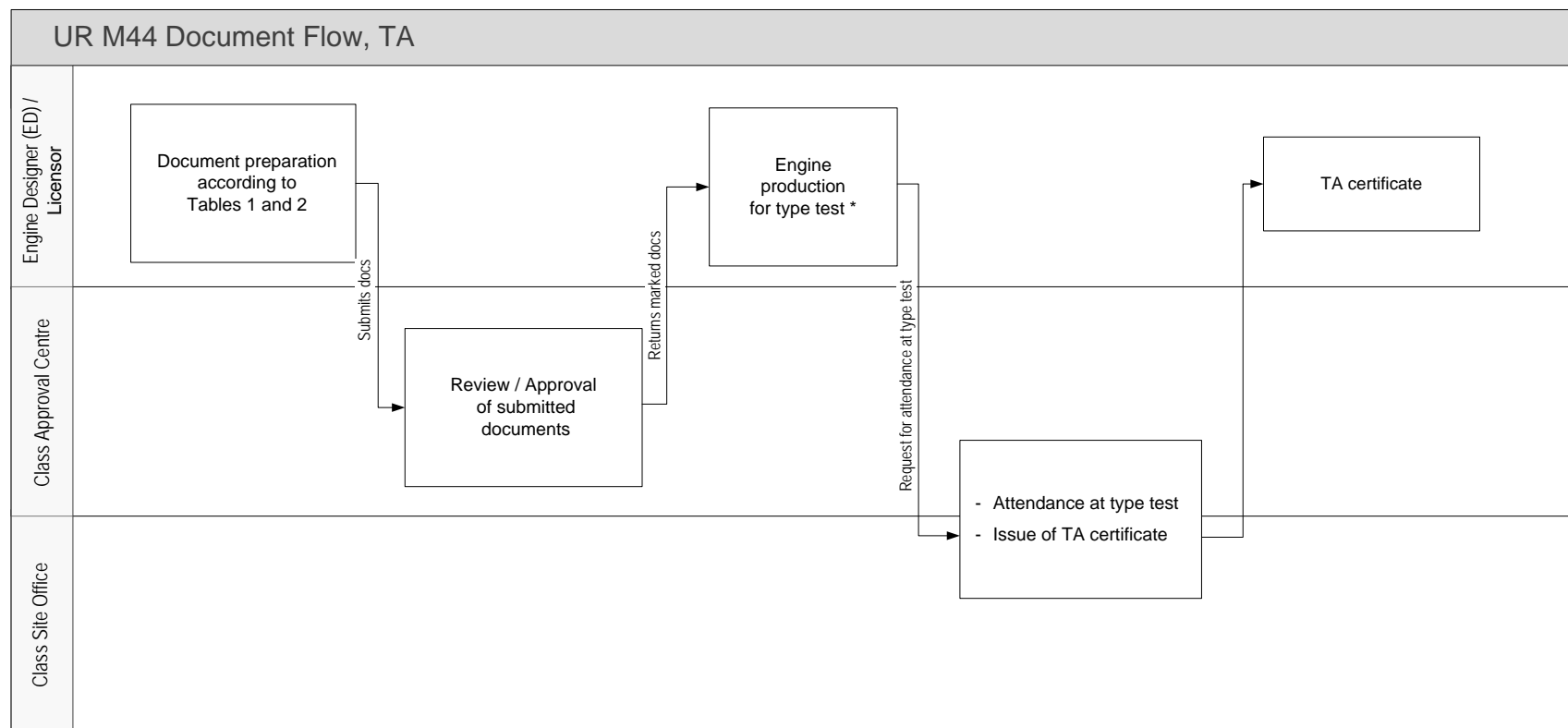

\* May also be produced by licensee

Figure 1 Type approval document flow

**M44**  
(cont)

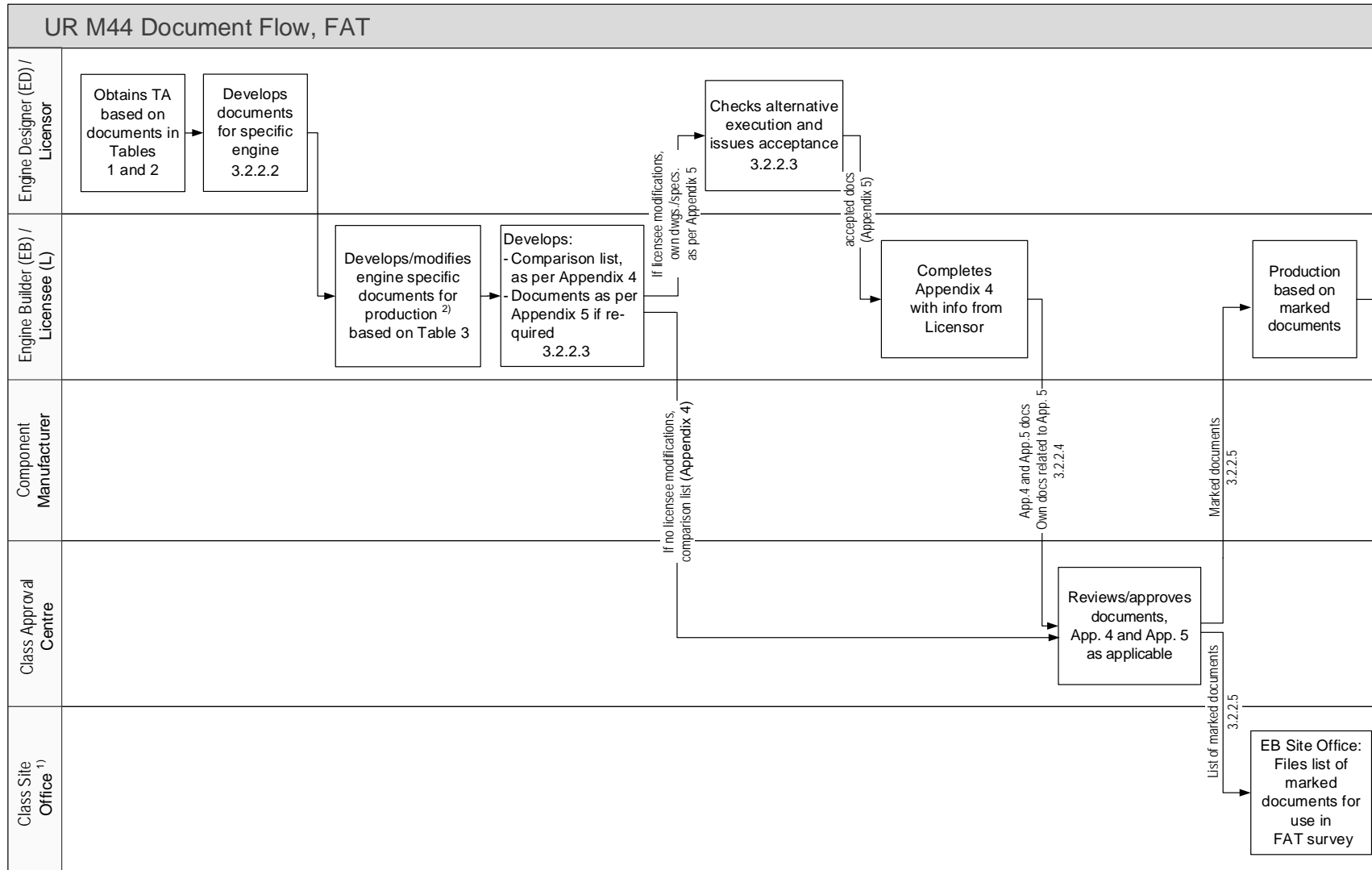

<sup>1)</sup> Class Site office with responsibility for engine builder and/or component manufacturers in different locations  
<sup>2)</sup> For alternative execution, see 5.3

**Figure 2 Engine certificate document flow**



**M44**  
(cont)

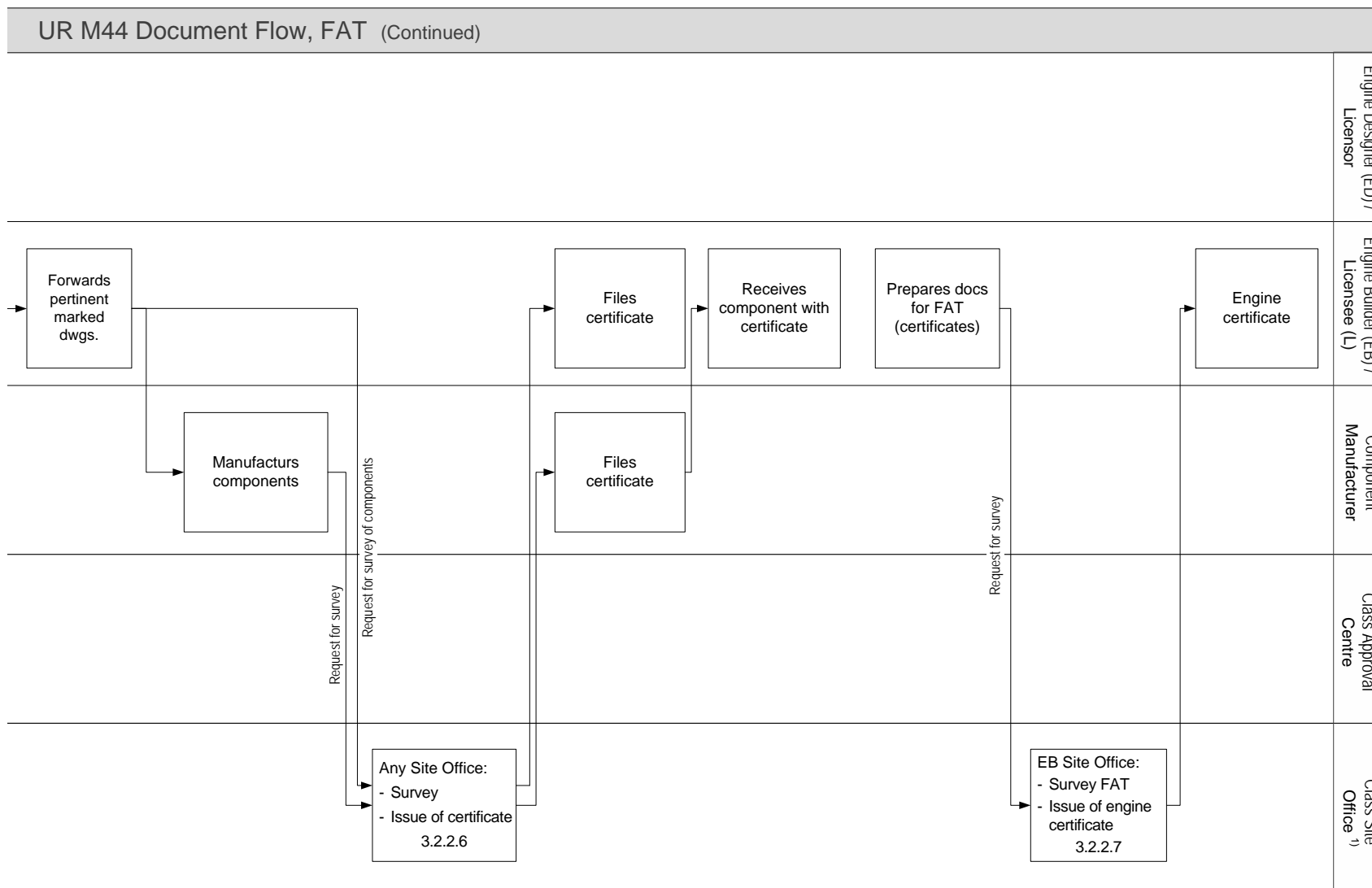

**Figure 2 Engine certificate document flow (continued)**

**M44**  
(cont)

**UR M44 - APPENDIX 3 - Data Sheet and Engine Particulars**

Please enclose additional pages if the text fields of this form are insufficient.

General Data

Engine designer / engine builder \_\_\_\_\_

Engine Type \_\_\_\_\_

Manufactured since \_\_\_\_\_ Number of delivered marine engines \_\_\_\_\_

Performance Data Related to: Barometric pressure 1,000 mbar; Air temperature 45°C; Relative humidity 60%; seawater temp. 32 °C

Max. continuous rating	kW/cyl.				
Rated speed	1/min				
Mean indicative pressure	bar				
Mean effective pressure	bar				
Max. firing pressure	bar				
Charge air pressure	bar				
Compression ratio	-				
Mean piston speed	m/s				

- Design
- |  |  |
|--|--|
| <input type="checkbox"/> Main engine, single propulsion    | <input type="checkbox"/> Main engine, multi engine plant               |
| <input type="checkbox"/> Auxiliary engine                  | <input type="checkbox"/> Emergency engine                              |
| <input type="checkbox"/> 2-stroke                          | <input type="checkbox"/> 4-stroke                                      |
| <input type="checkbox"/> Crosshead                         | <input type="checkbox"/> Trunk piston                                  |
| <input type="checkbox"/> In-line engine                    | <input type="checkbox"/> V-engine                                      |
| <input type="checkbox"/> Reversible                        | <input type="checkbox"/> Non-reversible                                |
| <input type="checkbox"/> With supercharging                | <input type="checkbox"/> Without supercharging                         |
| <input type="checkbox"/> With charge air cooling           | <input type="checkbox"/> Without charge air cooling                    |
| <input type="checkbox"/> Constant-pressure charging system | <input type="checkbox"/> Pulsating pressure system                     |
| <input type="checkbox"/> Direct injection                  | <input type="checkbox"/> Indirect injection                            |
| <input type="checkbox"/> Injection operation by cams       | <input type="checkbox"/> Injection operation electronically controlled |
| <input type="checkbox"/> Valve operation by cams           | <input type="checkbox"/> Valve operation electronically controlled     |
| <input type="checkbox"/> Liquid fuel                       | <input type="checkbox"/> Gaseous fuel                                  |
| <input type="checkbox"/> Dual fuel                         |  |

Number of cylinders \_\_\_\_\_ V-angle \_\_\_\_\_  
 mm mm  
 Bore Stroke

- Crankshaft Material  open die forged  cont grain flow forged  free form forged  cast  
 Design  solid  semi-built

**M44**  
(cont)

Firing order

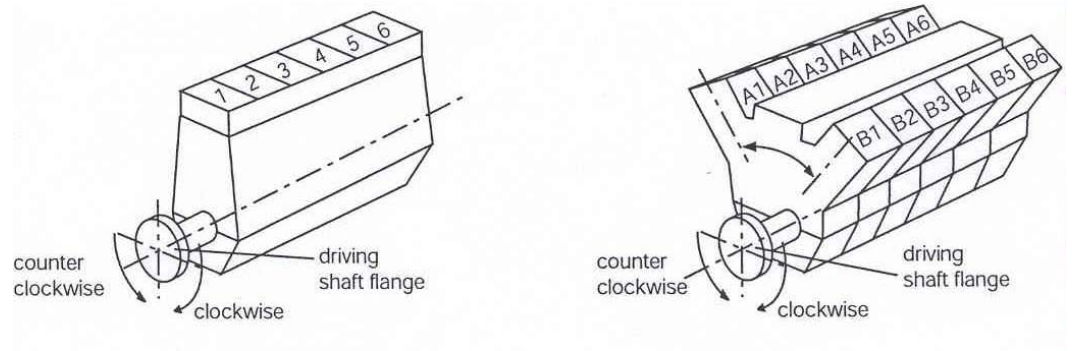

Number of cylinders	Clockwise (f.o.)	Counter clockwise (f.o.)

Supercharging devices	No. of cyl.	No. of aux. blo.	No. of CAC	No. of TC	TC manufacturer / type	Type approval certificate No. of TC

TC lubricating oil supply by  engine lub. oil system  TC internal lub. oil system

**Inclination limits** Engine operation is safeguarded under following inclined positions

Athwartship	static	15.0 °	<input type="checkbox"/> Yes	<input type="checkbox"/> No
		22.5 °	<input type="checkbox"/> Yes	<input type="checkbox"/> No
		30.0 °	<input type="checkbox"/> Yes	<input type="checkbox"/> No
	dynamic	22.5 °	<input type="checkbox"/> Yes	<input type="checkbox"/> No
		30.0 °	<input type="checkbox"/> Yes	<input type="checkbox"/> No
For-and-aft	static	5.0 °	<input type="checkbox"/> Yes	<input type="checkbox"/> No
		10.0 °	<input type="checkbox"/> Yes	<input type="checkbox"/> No
	dynamic	7.5 °	<input type="checkbox"/> Yes	<input type="checkbox"/> No
		10.0 °	<input type="checkbox"/> Yes	<input type="checkbox"/> No

**M44**  
**(cont)**

Speed governor	Engine application (Main/Aux/Emgcy)	Manufacturer / type	Kind of operation	Type approval cert. No. (if electric / electronic gov.)

Overspeed protection Independent overspeed protection available  Yes  No

Kind of operation \_\_\_\_\_

Manufacturer / type, if electronic \_\_\_\_\_ Type approval certificate No. \_\_\_\_\_

Electronic systems Engine control and management system

Manufacturer / type \_\_\_\_\_ Type approval certificate No. \_\_\_\_\_

Crankcase safety device Relief valves available  Yes  No

Manufacturer / type \_\_\_\_\_ Type approval certificate No. \_\_\_\_\_

No. of cyl.	Total crankcase gross volume incl. attachments	Type and size of relief valve	Relief area per relief valve	No. of relief valves

Oil mist detector available  Yes  No

Manufacturer / type \_\_\_\_\_ Type approval certificate No. \_\_\_\_\_

Starting system

Kind of operation \_\_\_\_\_

Safety devices in a starting air system. A flame arrestor or a bursting disk is installed

- before each starting valve  Yes  No
- in the starting air manifold  Yes  No

**M44**  
**(cont)**

	<b>Cylinder overpressure</b>	Cylinder overpressure warning device	<input type="checkbox"/> Yes	<input type="checkbox"/> No
		Design	bar Opening pressure	
<b>Allowable fuels</b>	Classification according to ISO 8216			
	Marine distillate fuel	DMX	<input type="checkbox"/> Yes	<input type="checkbox"/> No
		DMA, DMB, DMC	<input type="checkbox"/> Yes	<input type="checkbox"/> No
	Marine residual fuel	cSt	<input type="checkbox"/> Yes	<input type="checkbox"/> No
		Max. kinematic viscosity at 50°C		
	Gas	Kind of gas	<input type="checkbox"/> Yes	<input type="checkbox"/> No
<b>Engine attached</b>	<b>filter</b>	Lubricating oil filter		
		Single	<input type="checkbox"/> Yes	<input type="checkbox"/> No
		Duplex	<input type="checkbox"/> Yes	<input type="checkbox"/> No
		Automatic	<input type="checkbox"/> Yes	<input type="checkbox"/> No
	Fuel oil filter	Single	<input type="checkbox"/> Yes	<input type="checkbox"/> No
		Duplex	<input type="checkbox"/> Yes	<input type="checkbox"/> No
		Automatic	<input type="checkbox"/> Yes	<input type="checkbox"/> No
<b>Engine driven</b>	<b>pumps</b>	Main lubricating oil pump	<input type="checkbox"/> Yes	<input type="checkbox"/> No
		Sea cooling water pump	<input type="checkbox"/> Yes	<input type="checkbox"/> No
		LT-fresh cooling water pump	<input type="checkbox"/> Yes	<input type="checkbox"/> No
		HT-fresh cooling water pump	<input type="checkbox"/> Yes	<input type="checkbox"/> No
		Fuel oil booster pump	<input type="checkbox"/> Yes	<input type="checkbox"/> No
<b>Main engine</b>	<b>emergency operation</b>	At failure of one auxiliary blower, the engine can be started and operated at partial load.	<input type="checkbox"/> Yes	<input type="checkbox"/> No
		At failure of one turbo charger engine operation can be continued.	<input type="checkbox"/> Yes	<input type="checkbox"/> No
	<b>Remarks</b>			

Place / Date	Stamp	Name and Signature
--------------	-------	--------------------

Enclosures

**M44**  
(cont)

UR M44 - APPENDIX 4 - Tabular Listing of Licensor's and Licensee's Drawing and Data

Licensee: \_\_\_\_\_

Licensor: \_\_\_\_\_

Licensee Engine No. : \_\_\_\_\_

Engine type: \_\_\_\_\_

No.	Components or System	Licensor			Licensee		Has Design been modified by Licensee?		If Yes, indicate following information	
		Dwg. No. & Title	Rev. No.	Date of Class Approval or Review	Dwg. No.	Rev. No.	Yes	No	Identification of Alternative approved by Licensor	Date of Class Approval or Review of Licensee Dwg.
1										
2										
3										
4										
5										
6										
7										
8										
9										
...										

I attest the above information to be correct and accurate.

Person in Charge (Licensee):

\_\_\_\_\_  
Printed Name

\_\_\_\_\_  
Signature

Date: \_\_\_\_\_

**M44**  
(cont)

**UR M44 - APPENDIX 5 SAMPLE TEMPLATE FOR CONFIRMATION OF THE LICENSOR'S  
ACCEPTANCE OF LICENSEE'S MODIFICATIONS**

<i>Engine Licensee Proposed Alternative to Licensor's Design</i>			
<i>Licensee information</i>			
Licensee:		Ref No.:	
Description:		Info No.:	
Engine type:		Main Section:	
Engine No.:		Plant Id.:	
Design Spec: <input type="checkbox"/> General <input type="checkbox"/> Specific Nos:			
<i>Licensor design:</i>	<small>State relevant part or drawing numbers. Insert drawing clips or pictures. Add any relevant information</small>		<i>Licensee Proposed Alternative</i>
		For example:	
		<ul style="list-style-type: none"> <li>• Differences in geometry</li> <li>• Differences in the functionality</li> <li>• Material</li> <li>• Hardness</li> <li>• Surface condition</li> <li>• Alternative standard</li> <li>• Licensee production information introduced on the drawing</li> <li>• Weldings or castings</li> <li>• etc.</li> </ul>	
Reason:	<input type="checkbox"/> Licensee's production <input type="checkbox"/> Sub-supplier's production <input type="checkbox"/> Cost down <input type="checkbox"/> Tools	Interchangeability w. licensor design  <input type="checkbox"/> Yes <input type="checkbox"/> No	Non-conformity Report Research, Assessment, Evaluation  <input type="checkbox"/> NCR <input type="checkbox"/> RAE
			Certified by licensee: Initials: Date:
<b>Licensor comments</b>			
LoAE:	<input type="checkbox"/> Accepted as alternative execution <small>(Licensor undertakes responsibility)</small> <input type="checkbox"/> No objection <input type="checkbox"/> Not acceptable <small>(Licensee undertakes responsibility)</small>	NCR: <input type="checkbox"/> Approved <input type="checkbox"/> Conditionally approved <input type="checkbox"/> Rejected	Certified by licensor: Initials: Date:
Licensor ref.:			Date:
Licensee ref.:			Date:

End of  
Document