

S10 Rudders, Sole Pieces and Rudder Horns

(1986)
 (Rev.1
 1990)
 (Corr.1
 July
 1999)
 (Corr.2
 July
 2003)
 (Rev.2
 May
 2010)
 (Rev.3
 Mar
 2012)

S10.1 General

1.1 Basic assumptions

1.1.1 The following requirements apply to ordinary profile rudders, without any special arrangement for increasing the rudder force, such as fins, flaps, steering propellers, etc. Rudders not conforming to the ordinary types will be subject to special consideration.

This UR does not apply to CSR Bulk Carriers.

1.2 Design considerations

1.2.1 Effective means are to be provided for supporting the weight of the rudder without excessive bearing pressure, e.g. by a rudder carrier attached to the upper part of the rudder stock. The hull structure in way of the rudder carrier is to be suitably strengthened.

1.2.2 Suitable arrangements are to be provided to prevent the rudder from lifting.

1.2.3 In rudder trunks which are open to the sea, a seal or stuffing box is to be fitted above the deepest load waterline, to prevent water from entering the steering gear compartment and the lubricant from being washed away from the rudder carrier. If the top of the rudder trunk is below the deepest waterline, two separate stuffing boxes are to be provided.

1.3 Materials

1.3.1 Rudder stocks, pintles, coupling bolts, keys and cast parts of rudders are to be made of rolled, forged or cast carbon manganese steel in accordance with unified requirements W7, W8 and W11.

For rudder stocks, pintles, keys and bolts the minimum yield stress is not to be less than 200 N/mm². The following requirements are based on a material's yield stress of 235 N/mm². If material is used having a yield stress differing from 235 N/mm² the material factor is to be determined as follows:

Note:

1. Changes introduced in Rev.3 are to be uniformly implemented by IACS Members for ships contracted for construction on or after 1 January 2013.
2. The "contracted for construction" date means the date on which the contract to build the vessel is signed between the prospective owner and the shipbuilder. For further details regarding the date of "contract for construction", refer to IACS Procedural Requirement (PR) No. 29.

S10 (cont)

$$K = \left(\frac{235}{\sigma_F} \right)^e$$

with

$$e = 0.75 \text{ for } \sigma_F > 235 \text{ N/mm}^2$$

$$e = 1.00 \text{ for } \sigma_F \leq 235 \text{ N/mm}^2$$

$$\sigma_F = \text{yield stress (N/mm}^2\text{) of material used, and is not to be taken greater than } 0.7\sigma_T \text{ or } 450 \text{ N/mm}^2, \text{ whichever is the smaller value}$$

$$\sigma_T = \text{tensile strength of material used}$$

1.3.2 Before significant reductions in rudder stock diameter due to the application of steels with yield stresses exceeding 235 N/mm² are granted, the Society may require the evaluation of the rudder stock deformations. Large deformations should be avoided in order to avoid excessive edge pressures in way of bearings.

1.3.3 Welded parts of rudders are to be made of approved rolled hull materials. Required scantlings may be reduced when higher tensile steels are applied. The material factor according to UR S4 is to be used.

S10.2 Rudder force and rudder torque

2.1 Rudder blades without cut-outs (Fig. 1)

2.1.1 The rudder force upon which the rudder scantlings are to be based is to be determined from the following formula:

$$C_R = K_1 \cdot K_2 \cdot K_3 \cdot 132 \cdot A \cdot V^2 \cdot K_{th} \quad [\text{N}]$$

Where:

$$C_R = \text{rudder force} \quad [\text{N}];$$

$$A = \text{area of rudder blade} \quad [\text{m}^2];$$

$$V = \text{maximum service speed (knots) with the ship on summer load waterline. When the speed is less than 10 knots, } V \text{ is to be replaced by the expression:}$$

$$V_{\min} = (V + 20) / 3$$

For the astern condition the maximum astern speed is to be used, however, in no case less than:

$$V_{\text{astern}} = 0.5 V$$

$$K_1 = \text{factor depending on the aspect ratio } \lambda \text{ of the rudder area;}$$

$$K_1 = (\lambda + 2) / 3, \text{ with } \lambda \text{ not to be taken greater than } 2;$$

$$\lambda = b^2 / A_t, \text{ where } b = \text{mean height of the rudder area [m]. Mean breadth and mean height of rudder are calculated acc. to the coordinate system in Fig. 1;}$$

S10
(cont)

A_t = sum of rudder blade area A and area of rudder post or rudder horn, if any, within the height b [m^2];

K_3 = 0.8 for rudders outside the propeller jet;
= 1.15 for rudders behind a fixed propeller nozzle;
= 1.0 otherwise;

K_{th} = $C_R(C_{th}) / C_R(C_{th} = 1.0)$, C_{th} = thrust coefficient;

K_{th} is usually equal to 1.0 for rudders behind the propeller. For cases, where C_{th} is larger than one, it is left to the discretion of each individual society to consider the factor K_{th} with thrust coefficient C_{th} larger than 1.

S10

(cont)

Fig. 1

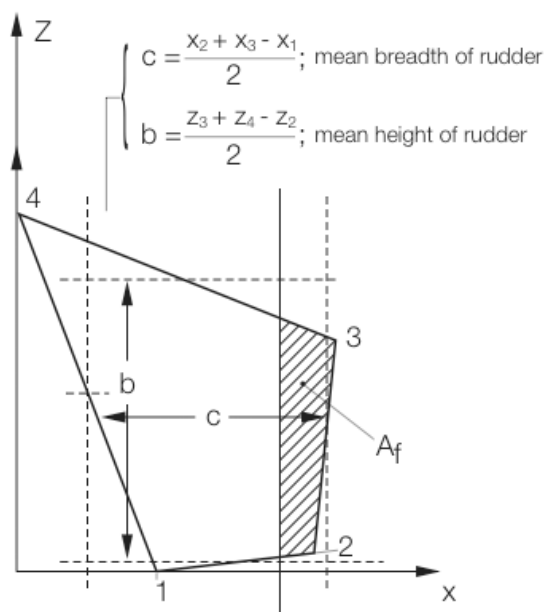
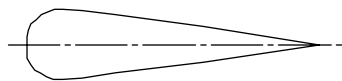
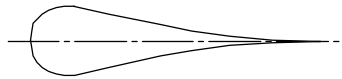
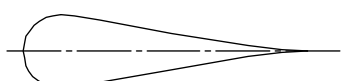

Table 1

Profile Type	K_2	
	Ahead condition	Astern condition
NACA-00 Gottingen-profiles 	1.1	0.80
Hollow profiles 	1.35	0.90
Flat side profiles 	1.1	0.90

S10 (cont)

2.1.2 The rudder torque is to be calculated for both the ahead and astern condition according to the formula:

$$Q_R = C_R r \quad [\text{Nm}]$$

$$r = c (\alpha - k) \quad [\text{m}]$$

c = mean breadth of rudder area [m], see Fig. 1

α = 0.33 for ahead condition

α = 0.66 for astern condition

k = balance factor as follows

k = A_f / A , where A_f = portion of the rudder blade area situated ahead of the centre line of the rudder stock

$$r_{\min} = 0.1c \quad [\text{m}] \quad \text{for ahead condition}$$

2.2 Rudder blades with cut-outs (semi-spade rudders)

The total rudder force C_R is to be calculated according to S10.2.1.1. The pressure distribution over the rudder area, upon which the determination of rudder torque and rudder blade strength is to be based, is to be derived as follows:

The rudder area may be divided into two rectangular or trapezoidal parts with areas A_1 and A_2 , so that $A = A_1 + A_2$ (see Fig. 2).

Fig. 2

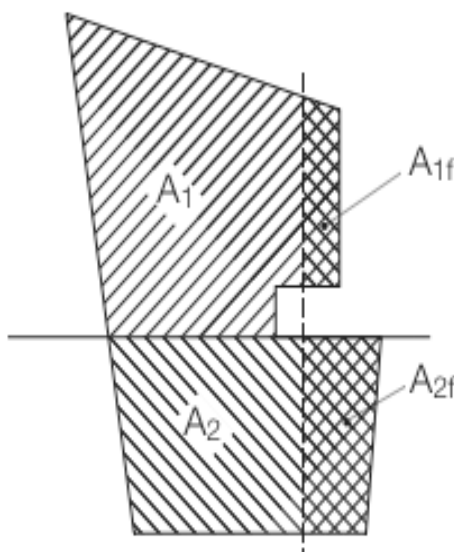

S10**(cont)**

The levers r_1 and r_2 are to be determined as follows:

$$r_1 = c_1 (\alpha - K_1) \quad [\text{m}]$$

$$r_2 = c_2 (\alpha - K_2) \quad [\text{m}]$$

c_1, c_2 = mean breadth of partial areas A_1, A_2 determined, where applicable, in accordance with Fig.1 in S10.2.1.1

$$k_1 = \frac{A_{1f}}{A_1}$$

$$k_2 = \frac{A_{2f}}{A_2}$$

α = 0.33 for ahead condition

α = 0.66 for astern condition

For parts of a rudder behind a fixed structure such as the rudder horn

α = 0.25 for ahead condition

α = 0.55 for astern condition

The resulting force of each part may be taken as:

$$C_{R1} = C_R \frac{A_1}{A} \quad [\text{N}]$$

$$C_{R2} = C_R \frac{A_2}{A} \quad [\text{N}]$$

The resulting torque of each part may be taken as:

$$Q_{R1} = C_{R1} r_1 \quad [\text{Nm}]$$

$$Q_{R2} = C_{R2} r_2 \quad [\text{Nm}]$$

The total rudder torque is to be calculated for both the ahead and astern condition according to the formula:

$$Q_R = Q_{R1} + Q_{R2} \quad [\text{Nm}]$$

For ahead condition Q_R is not to be taken less than

$$Q_{R\min} = 0.1 C_R \frac{A_1 c_1 + A_2 c_2}{A}$$

S10

(cont)

S10.3 Rudder stock scantlings in way of the tiller

The rudder stock diameter required for the transmission of the rudder torque is to be dimensioned such that the torsional stress will not exceed the following value:

$$\tau_t = 68 / K$$

The rudder stock diameter for the transmission of the rudder torque is therefore not to be less than:

$$d_t = 4.2\sqrt[3]{Q_R K} \quad [\text{mm}]$$

Q_R = total rudder torque [Nm] as calculated in S10.2.1.2 and/or S10.2.2.

For the application of the material factor K see also S10.1.3.2.

S10.4 Rudder strength calculation

4.1 The rudder force and resulting rudder torque as given in para S2 causes bending moments and shear forces in the rudder body, bending moments and torques in the rudder stock, supporting forces in pintle bearings and rudder stock bearings and bending moments, shear forces and torques in rudder horns and heel pieces. The rudder body is to be stiffened by horizontal and vertical webs enabling it to act as a bending girder.

4.2 The bending moments, shear forces and torques as well as the reaction forces are to be determined by a direct calculation or by an approximate simplified method considered appropriate by each individual society. For rudders supported by sole pieces or rudder horns these structures are to be included in the calculation model in order to account for the elastic support of the rudder body. Guidelines for calculation of bending moment and shear force distribution are given in an annex to this requirement.

4.3 Rudder stock scantlings due to combined loads

If the rudder stock is subjected to combined torque and bending, the equivalent stress in the rudder stock is not to exceed $118 / K$.

The equivalent stress is to be determined by the formula:

$$\sigma_c = \sqrt{\sigma_b^2 + 3\tau_t^2} \quad [\text{N/mm}^2]$$

$$\text{Bending stress: } \sigma_b = 10.2 M / d_c^3 \quad [\text{N/mm}^2]$$

$$\text{Torsional stress: } \tau_t = 5.1 Q_R / d_c^3 \quad [\text{N/mm}^2]$$

The rudder stock diameter is therefore not to be less than:

$$d_c = d_t \sqrt[6]{1 + 4 / 3 [M / Q_R]^2} \quad [\text{mm}]$$

M = bending moment [Nm] at the station of the rudder stock considered

S10

(cont)

S10.5 Rudder blade scantlings

5.1 Permissible stresses

The section modulus and the web area of a horizontal section of the rudder blade made of ordinary hull structural steel are to be such that the following stresses will not be exceeded:

a) rudder blades without cut-outs (Fig. 1)

- | | |
|--|-----------------------|
| (i) bending stress σ_b | 110 N/mm ² |
| (ii) shear stress τ | 50 N/mm ² |
| (iii) equivalent stress $\sigma_e = \sqrt{\sigma_b^2 + 3\tau^2}$ | 120 N/mm ² |

b) rudder blades with cut-outs (e.g. semi-spade rudders. Fig. 2 of S10)

- | | |
|--|--|
| (i) bending stress σ_b | 75 N/mm ² |
| (ii) shear stress τ | 50 N/mm ²
in way of cut-outs |
| (iii) equivalent stress $\sigma_e = \sqrt{\sigma_b^2 + 3\tau^2}$ | 100 N/mm ² |

5.2 Rudder plating

The thickness of the rudder side, top and bottom plating made of ordinary hull structural steel is not to be less than:

$$t = 5.5s\beta\sqrt{d + C_R 10^{-4}/A} + 2.5 \quad [\text{mm}]$$

d = summer loadline draught [m] of the ship;

C_R = rudder force [N] according to S10.2.1.1;

A = rudder area [m²];

$$\beta = \sqrt{1.1 - 0.5[s/b]^2}; \quad \text{max. } 1.00 \text{ if } b/s \geq 2.5$$

s = smallest unsupported width of plating in [m];

b = greatest unsupported width of plating in [m].

The thickness of the nose plates may be increased to the discretion of each society. The thickness of web plates is not to be less than 70% of the rudder side plating, however not less than 8 mm. For higher tensile steels the material factor according to UR S4 is to be used correspondingly.

5.3 Single plate rudders

5.3.1 Mainpiece diameter

The mainpiece diameter is calculated according to S10.3 and S10.4.3 respectively. For spade rudders the lower third may taper down to 0.75 times stock diameter.

S10

(cont)

5.3.2 Blade thickness

The blade thickness is not to be less than:

$$t_b = 1.5 s V + 2.5 \quad [\text{mm}]$$

s = spacing of stiffening arms in [m], not to exceed 1 m;

v = speed in knots, see S10.2.1.1.

5.3.3 Arms

The thickness of the arms is not to be less than the blade thickness

$$t_a = t_b$$

The section modulus is not to be less than

$$Z_a = 0.5 s C_1^2 V^2 \quad [\text{cm}^3];$$

C₁ = horizontal distance from the aft edge of the rudder to the centreline of the rudder stock, in metres

For higher tensile steels the material factor according to UR S4 is to be used correspondingly.

S10.6 Rudder stock couplings

6.1 Horizontal flange couplings

6.1.1 The diameter of the coupling bolts is not to be less than:

$$d_b = 0.62 \sqrt{d^3 K_b / n e_m K_s} \quad [\text{mm}]$$

d = stock diameter, the greater of the diameters d_t or d_c according to S10.3 and S10.4.3 [mm];

n = total number of bolts, which is not to be less than 6;

e_m = mean distance [mm] of the bolt axes from the centre of the bolt system;

K_s = material factor for the stock as given in S10.1.3.1;

K_b = material factor for the bolts as given in S10.1.3.1.

6.1.2 The thickness of the coupling flanges is not to be less than determined by the following formulae:

$$t_f = d_b \sqrt{K_f / K_b}$$

K_f = material factor for flange as given in S10.1.3.1;

t_f min = 0.9 d_b;

S10

(cont)

d_b = bolt diameter calculated for a number of bolts not exceeding 8.

6.1.3 The width of material outside the bolt holes is not to be less than $0.67 d_b$.

6.2 Cone couplings

6.2.1 Cone couplings without hydraulic arrangements for mounting and dismounting the coupling should have a taper on diameter of 1:8 - 1:12 and be secured by a slugging nut.

The taper length (1) of rudder stocks fitted into the rudder blade and secured by a nut should generally not be less than 1.5 times the rudder stock diameter (d_o) at the top of the rudder.

For couplings between stock and rudder a key is to be provided. Determination of scantlings of the key is left to the discretion of each society.

Fig. 4

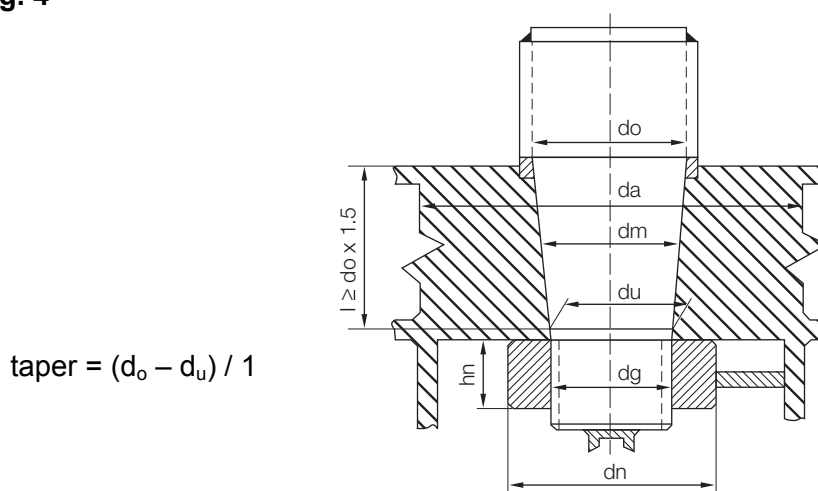

6.2.2 The dimensions of the slugging nut are to be as follows (see Fig. 4):

external thread diameter: $d_g \geq 0.65 d_o$

length of nut: $h_n \geq 0.6 d_g$

outer diameter of nut: $d_n \geq 1.2 d_u$, or $1.5 d_g$
whichever is the greater.

6.2.3 Cone couplings with hydraulic arrangements for mounting and dismounting the coupling (mounting with oil injection and hydraulic nut) should have a taper on diameter of 1:12 - 1:20.

The push-up oil pressure and the push-up length are to be specially considered in each individual case based on a calculation to be submitted by the yard.

6.3 Vertical flange couplings

6.3.1 The diameter of the coupling bolts is not to be less than

$$d_b = 0.81d / \sqrt{n} \times \sqrt{k_b/k_s}$$

where

S10 (cont)

- d = stock diameter;
- n = total number of bolts, which is not to be less than 8;
- k_b = material factor for bolts as given in S10.1.3.1;
- k_s = material factor for stock as given in S10.1.3.1.

6.3.2 The first moment of area of the bolts about the centre of the coupling, m, must be at least:

$$m = 0.00043 d^3$$

6.3.3 The thickness of the coupling flanges must be at least equal to the bolt diameter, and the width of the flange material outside the bolt holes must be greater than or equal to 0.67 d_b .

S10.7 Pintles

7.1 Pintles are to have a conical attachment to the gudgeons with a taper on diameter not greater than:

1:8 - 1:12 for keyed and other manually assembled pintles applying locking by slugging nut,

1:12 - 1:20 on diameter for pintles mounted with oil injection and hydraulic nut.

The length of the pintle housing in the gudgeon is not to be less than the maximum pintle diameter

$$d_p = 0.35 \sqrt{B k_p}$$

where B is the relevant bearing force and k_p is the material factor as given in S10.1.3.1.

7.2 The minimum dimensions of threads and nuts are to be determined according to para S10.6.2.2.

S10.8 Rudder stock-, rudder shaft- and pintle bearings

8.1 Minimum bearing surface

An adequate lubrication is to be provided.

The bearing surface A_b (defined as the projected area: length x outer diameter of liner) is not to be less than:

$$A_b = P / q_a \quad [\text{mm}^2]$$

where

P = reaction force [N] in bearing as determined in S10.4.2;

q_a = allowable surface pressure according to the table below.

S10 (cont)

The maximum surface pressure q_a for the various combinations is to be taken as reported in the table below. Higher values than given in the table may be taken in accordance with makers' specifications if they are verified by tests:

Bearing material	q_a [N/mm ²]
lignum vitae	2.5
white metal, oil lubricated	4.5
synthetic material with hardness between 60 and 70 Shore D ¹⁾	5.5
steel ²⁾ and bronze and hot-pressed bronze-graphite materials	7.0

- 1) Indentation hardness test at 23°C and with 50% moisture, acc. to a recognized standard. Synthetic bearing materials to be of approved type.
- 2) Stainless and wear-resistant steel in an approved combination with stock liner.

8.2 Length of bearings

The length/diameter ratio of the bearing surface is not to be greater than 1.2.

8.3 Bearing clearances

With metal bearings, clearances should not be less than $d_b / 1000 + 1.0$ [mm] on the diameter. If non-metallic bearing material is applied, the bearing clearance is to be specially determined considering the material's swelling and thermal expansion properties. This clearance ~~in no way~~ is not to be taken less than 1.5 mm on bearing diameter- unless a smaller clearance is supported by the manufacturer's recommendation and there is documented evidence of satisfactory service history with a reduced clearance.

S10.9 Strength of sole pieces and of rudder horns

9.1 Sole piece

Fig. 5

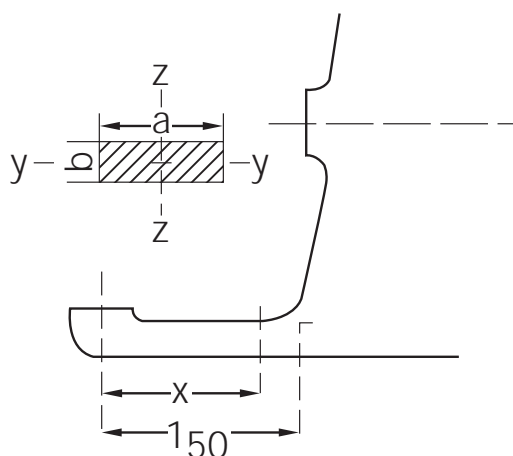

S10 (cont)

The section modulus around the vertical (z)-axis is not to be less than:

$$Z_z = M_b K / 80 \quad [\text{cm}^3]$$

The section modulus around the transverse (y)-axis is not to be less than:

$$Z_y = 0.5 Z_z$$

The sectional area is not to be less than:

$$A_s = B_1 K / 48 \quad [\text{mm}^2]$$

K = material factor as given S10.1.3.1 or UR S4 respectively.

9.1.1 Equivalent stress

At no section within the length ℓ_{50} is the equivalent stress to exceed $115 / K$. The equivalent stress is to be determined by the following formula:

$$\sigma_e = \sqrt{\sigma_b^2 + 3\tau^2} \quad [\text{N/mm}^2];$$

$$\sigma_b = M_b / Z_z(x) \quad [\text{N/mm}^2];$$

$$\tau = B_1 / A_s \quad [\text{N/mm}^2];$$

M_b = bending moment at the section considered [Nm];

$$M_b = B_1 x \quad [\text{Nm}];$$

$$M_{b\max} = B_1 \ell_{50} \quad [\text{Nm}];$$

B_1 = supporting force in the pintle bearing [N] (normally $B_1 = C_R / 2$).

9.2 Rudder horn

When the connection between the rudder horn and the hull structure is designed as a curved transition into the hull plating, special consideration should be given to the effectiveness of the rudder horn plate in bending and to the stresses in the transverse web plates.

The loads on the rudder horn are as follows:

$$M_b = \text{bending moment} = B_1 z \quad [\text{Nm}], \quad M_{b\max} = B_1 d \quad [\text{Nm}]$$

$$q = \text{shear force} = B_1 \quad [\text{N}]$$

$$M_T(z) = \text{torsional moment} = B_1 e(z) \quad [\text{Nm}]$$

see Fig. 6

S10

(cont)

Fig. 6

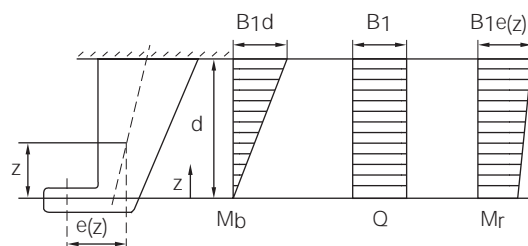

An estimate for B_1 is

$$B_1 = C_R b / (\ell_{20} + \ell_{30}) \quad [\text{N}].$$

For b , ℓ_{20} and ℓ_{30} , see Fig. 2 of annex.

The section modulus around the horizontal x-axis is not to be less than:

$$Z_x = M_b K / 67 \quad [\text{cm}^3].$$

The shear stress is not to be larger than:

$$\tau = 48 / K \quad [\text{N/mm}^2].$$

9.2.1 Equivalent stress

At no section within the length d is the equivalent stress to exceed $120 / K$. The equivalent stress is to be calculated by the following formula:

$$\sigma_e = \sqrt{\sigma_b^2 + 3(\tau^2 + \tau_T^2)} \quad [\text{N/mm}^2];$$

$$\sigma_b = M_b / Z_x \quad [\text{N/mm}^2]$$

$$\tau = B_1 / A_h \quad [\text{N/mm}^2]$$

$$\tau_T = M_T 10^3 / 2 A_T t_h \quad [\text{N/mm}^2]$$

A_h = effective shear area of rudder horn in y-direction;

A_T = area in the horizontal section enclosed by the rudder horn [mm^2];

t_h = plate thickness of rudder horn [mm];

K = material factor as given in S10.1.3.1 or UR S4 respectively.

9.3 Pintle housing

The bearing length L_p of the pintle is to be such that

$$D_p \leq L_p \leq 1.2 D_p$$

The length of the pintle housing in the gudgeon is not to be less than the pintle diameter D_p . The thickness of the pintle housing is not to be less than $0.25 D_p$.

S10

(cont)

Annex

Guidelines for calculation of bending moment and shear force distribution

1. General

The evaluation of bending moments, shear forces and support forces for the system rudder – rudder stock may be carried out for some basic rudder types as shown in Fig. 1 - 3 as outlined below.

2. Data for the analysis

$\ell_{10} - \ell_{50}$ = lengths of the individual girders of the system in [m];

$I_{10} - I_{50}$ = moments of inertia of these girders in [cm⁴].

For rudders supported by a sole piece the length ℓ_{20} is the distance between lower edge of rudder body and centre of sole piece and I_{20} the moment of inertia of the pintle in the sole piece.

Load of rudder body (general)

$$P_R = C_R / 10^3 \times \ell_{10} \quad [\text{kN/m}].$$

Load for semi-spade rudders

$$P_{R10} = C_{R2} / \ell_{10} \times 10^3 \quad [\text{kN/m}];$$

$$P_{R20} = C_{R1} / \ell_{10} \times 10^3 \quad [\text{kN/m}]$$

for C_R , C_{R1} , C_{R2} , see S10.2.2

Z = spring constant of support in the sole piece or rudder horn respectively;

$$Z = 6.18 \times I_{50} / \ell_{50}^3 \quad [\text{kN/m}] \text{ for the support in the sole piece (Fig. 1)}$$

I_{50} = moment of inertia of sole piece around the z-axis [cm⁴];

ℓ_{50} = effective length of sole piece in [m];

Z = $1 / (f_b + f_t)$ [kN/m] for the support in the rudder horn (Fig. 2);

f_b = unit displacement of rudder horn in [m] due to a unit force of 1 kN acting in the centre of support;

$$f_b = 1.3 d^3 / (6.18 I_n) \quad [\text{m/kN}] \text{ (guidance value);}$$

I_n = moment of inertia of rudder horn around the x-axis in [cm⁴]
(see also Fig. 6 of S10.9.2);

f_t = unit displacement due to torsion;

$$f_t = de^2 \sum u_i / t_i / (3.14 \times 10^8 F_T^2) \quad [\text{m/kN}];$$

S10

(cont)

- F_T = mean sectional area of rudder horn in [m²];
- u_i = breadth in [mm] of the individual plates forming the mean horn sectional area;
- t_i = thickness within the individual breadth u_i in [mm];

for e, d, see Fig. 2.

3. Moments and forces to be evaluated

The bending moment M_R and the shear force Q_1 in the rudder body, the bending moment M_b in the neck bearing and the support forces B_1 , B_2 , B_3 are to be evaluated. The so evaluated moments and forces are to be used for the stress analyses required by S10.4, S10.6, S10.8 and S10.9.

4. Estimates for spade rudders

For spade rudders the moments and forces may be determined by the following formulae:

$$M_b = C_R (\ell_{20} + (\ell_{10} (2 c_1 + c_2) / 3 (c_1 + c_2))) \quad [\text{Nm}];$$

$$B_3 = M_b / \ell_{30} \quad [\text{N}];$$

$$B_2 = C_R + B_3 \quad [\text{N}].$$

Fig. 1: Rudder supported by sole piece

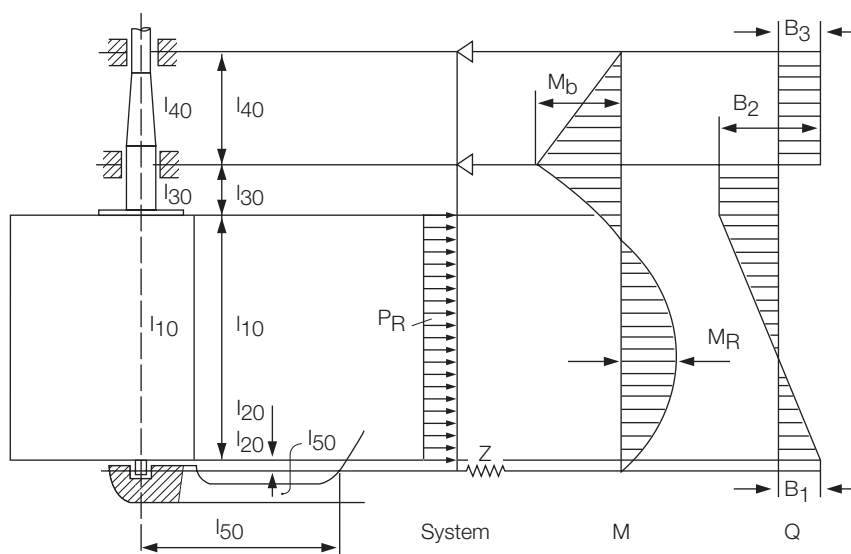

S10
(cont)

Fig. 2: Semi-spade rudder

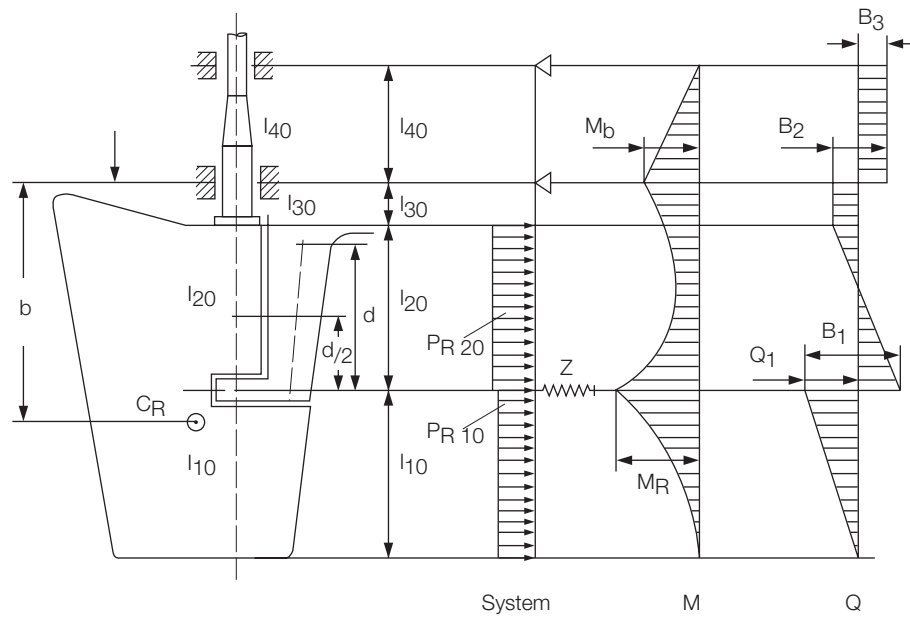
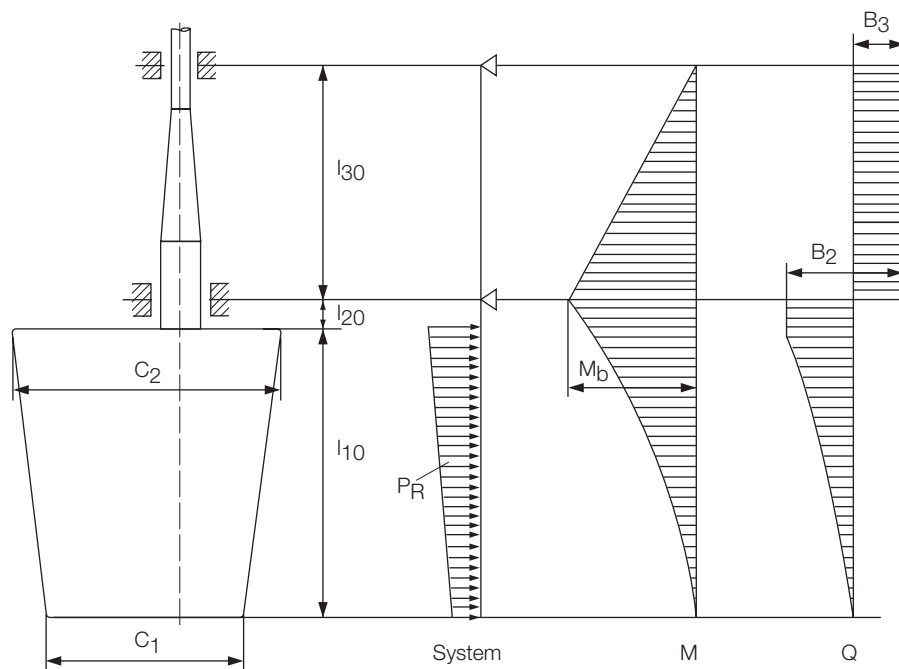

Fig.3: Spade rudder



End of Document