

TÜRK LOYDU



TL-I GC

Interpretations of the IMO Gas Code

July 2020

These interpretations are prepared by embedding related IACS Unified Interpretations. In order to have consistency, the numbering of the interpretations are kept as the same with related IACS Unified Interpretations.

Unless otherwise specified, these Rules apply according to the implementation dates as defined in each interpretation. See Rule Change Summary on TL website for revision details.

This latest edition incorporates all rule changes.

"General Terms and Conditions" of the respective latest edition will be applicable (see Rules for Classification and Surveys).

If there is a difference between the rules in English and in Turkish, the rule in English is to be considered as valid. This publication is available in print and electronic pdf version. Once downloaded, this document will become UNCONTROLLED. Please check the website below for the valid version.

<http://www.turkloydu.org>

All rights are reserved by Türk Loydu, and content may not be reproduced, disseminated, published, or transferred in any form or by any means, except with the prior written permission of **TL**.

TÜRK LOYDU

Head Office Postane Mah. Tersaneler Cad. No:26 Tuzla 34944 İSTANBUL / TÜRKİYE

Tel : (90-216) 581 37 00

Fax : (90-216) 581 38 00

E-mail : info@turkloydu.org

<http://www.turkloydu.org>

Regional Offices

Ankara Eskişehir Yolu Mustafa Kemal Mah. 2159. Sokak No : 6/4 Çankaya - ANKARA / TÜRKİYE

Tel : (90-312) 219 56 34

Fax : (90-312) 219 68 25

E-mail : ankara@turkloydu.org

İzmir Atatürk Cad. No :378 K.4 D.402 Kavalalılar Apt. 35220 Alsancak - İZMİR / TÜRKİYE

Tel : (90-232) 464 29 88

Fax : (90-232) 464 87 51

E-mail : izmir@turkloydu.org

Adana Çınarlı Mah. Atatürk Cad. Aziz Naci İş Merkezi No:5 K.1 D.2 Seyhan - ADANA / TÜRKİYE

Tel : (90- 322) 363 30 12

Fax : (90- 322) 363 30 19

E-mail : adana@turkloydu.org

CONTENTS

TL-I GC5 Closing Devices for Air Intakes

TL-I GC6 Cargo tank clearances

TL-I GC9 Guidance for sizing pressure relief systems for interbarrier spaces

TL-I GC10 Reliquefaction plant of motor-driven LNG-carriers

TL-I GC11 Loading of cargo C tanks for ships constructed before 1 July 2016 and subject to IMO International Code for the Construction and Equipment of Ships Carrying Liquefied Gases in Bulk (MSC.5(48))

TL-I GC13 Examination before and after the first loaded voyage

TL-I GC15 Closing Devices for Air Intakes

TL-I GC 16 Cargo tank clearances (on ships constructed on or After 1 July 2016)

TL- I GC5 Closing Devices for Air Intakes

Interpretation of paragraph 3.2.6 of the IMO International Code for the Construction and Equipment of Ships Carrying Liquefied Gases in Bulk (MSC.5(48)) as amended by resolutions MSC.17(58), MSC.30(61), MSC.32(63), MSC.59(67), MSC.103(73), MSC.177(79) and MSC.220(82)

Paragraph 3.2.6 may be interpreted as follows:

1. The requirement for fitting air intakes and openings with closing devices operable from inside the space in ships intended to carry toxic products should apply to spaces which are used for the ships' radio and main navigating equipment, cabins, mess rooms, toilets, hospitals, galleys, etc., but should not apply to **spaces not normally manned** such as deck stores, forecastle stores, engine room casings, steering gear compartments, workshops. The requirement does also not apply to cargo control rooms located within the cargo area.
2. When internal closing is required, this should include both ventilation intakes and outlets.
3. The closing devices should give a reasonable degree of gas tightness. Ordinary steel fire-flaps without gaskets/seals should normally not be considered satisfactory.

-
1. This interpretation is implemented on ships constructed on or after 1 January 1986 but before 1 July 2016.
 2. For ships whose keels are laid, or which are at a similar stage of construction, on or after 1 July 2016 refer to TL- I GC15.

TL- I GC6 Cargo tank clearances

Interpretation of section 3.5 of the INTERNATIONAL CODE FOR THE CONSTRUCTION AND EQUIPMENT OF SHIPS CARRYING LIQUEFIED GASES IN BULK (MSC.5(48)) as amended by resolutions MSC.17(58), MSC.30(61), MSC.32(63), MSC.59(67), MSC.103(73), MSC.177(79) and MSC.220(82)

This section may be interpreted as follows:

1. Designated passage ways below and above cargo tanks should have at least the cross sections as required by 3.5.3.1.3.
2. For the purpose of 3.5.1 or 3.5.2 the following should apply:
 - .1 Where the surveyor requires to pass between the surface to be inspected, flat or curved, and structural elements such as deckbeams, stiffeners, frames, girders etc., the distance between that surface and the free edge of the structural elements should be at least 380 mm. The distance between the surface to be inspected and the surface to which the above structural elements are fitted, eg deck, bulkhead or shell, should be at least 450 mm in case of a curved tank surface (eg in case of type C-tank) or 600 mm in case of a flat tank surface (eg in case of type A-tank). (See figure 1).
 - .2 Where the surveyor does not require to pass between the surface to be inspected and any part of the structure, for visibility reasons the distance between the free edge of that structural element and the surface to be inspected should be at least 50 mm or half the breadth of the structure's face plate, whichever is the larger. (See figure 2).
 - .3 If for inspection of a curved surface the surveyor requires to pass between that surface and another surface, flat or curved, to which no structural elements are fitted, the distance between both surfaces should be at least 380 mm. (See figure 3). Where the surveyor does not require to pass between that curved surface and another surface, a smaller distance than 380 mm may be accepted taking into account the shape of the curved surface.
 - .4 If for inspection of an approximately flat surface the surveyor requires to pass between two approximately flat and approximately parallel surfaces, to which no structural elements are fitted, the distance between those surfaces should be at least 600 mm. (See figure 4).

Note:

1. This interpretation is implemented on ships constructed on or after 1 January 1986 but before 1 July 2016.
2. For ships whose keels are laid, or which are at a similar stage of construction, on or after 1 July 2016 refer to TL- I GC16.

-
- .5 The minimum distances between a cargo tank sump and adjacent double bottom structure in way of a suction wells should not be less than shown in figure 5. If there is no suction well, the distance between the cargo tank sump and the inner bottom should not be less than 50 mm.
 - .6 The distance between a cargo tank dome and deck structures should not be less than 150 mm. (See figure 6).
 - .7 If necessary for inspection fixed or portable staging should be installed. This staging should not impair the distances required under .1 to .4.
 - .8 If fixed or portable ventilation ducting has to be fitted in compliance with 12.2 such ducting should not impair the distances required under .1 to .4.
3. For the purpose of sub-paragraph 3.5.3.1.2 and .1.3 the following should apply:
- .1 The term "minimum clear opening of not less than 600 x 600 mm" means that such openings may have corner radii up to 100 mm maximum.
 - .2 The term "minimum clear opening of not less than 600 x 800 mm" includes also an opening of the following size:

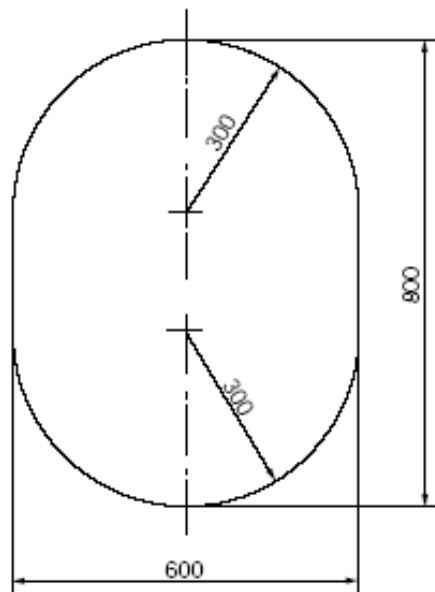

- .3 Circular access openings in type-C cargo tanks should have diameters of not less than 600 mm.

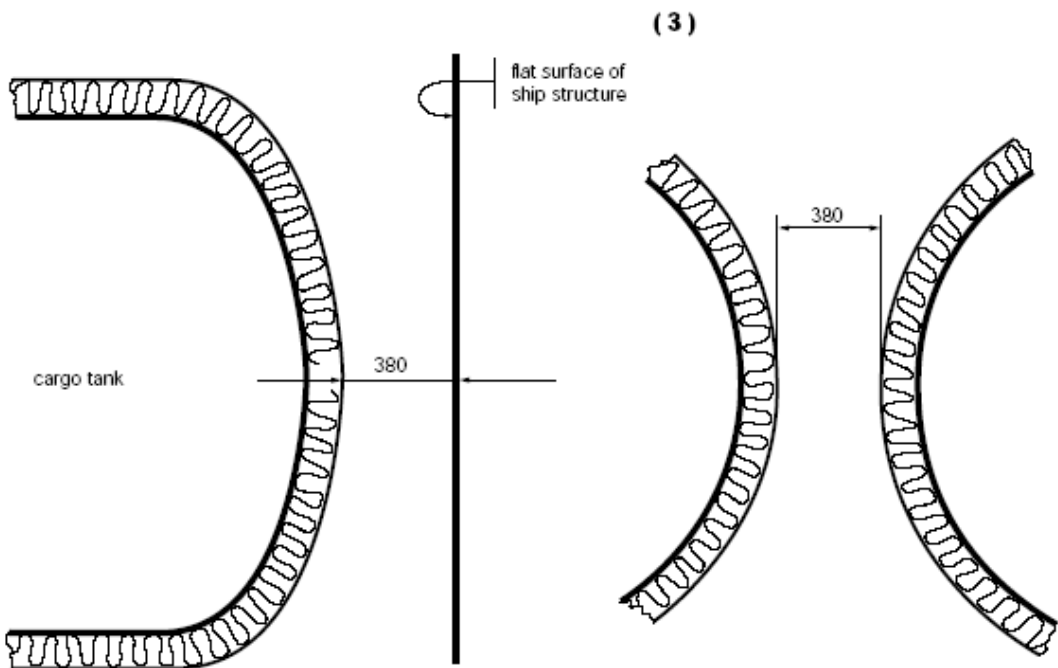
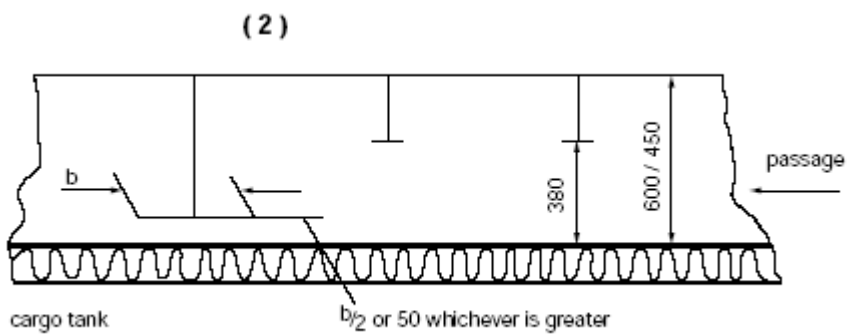
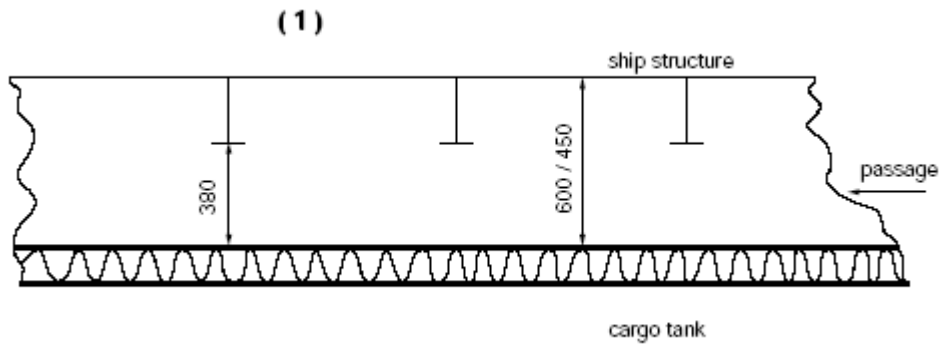

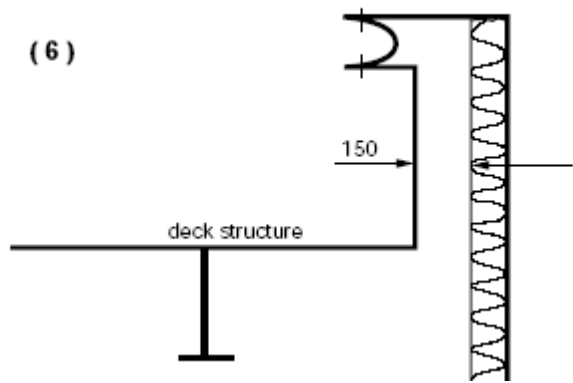
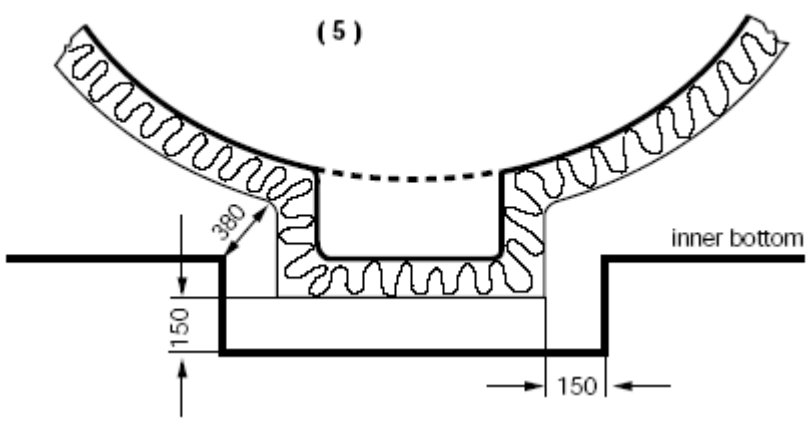
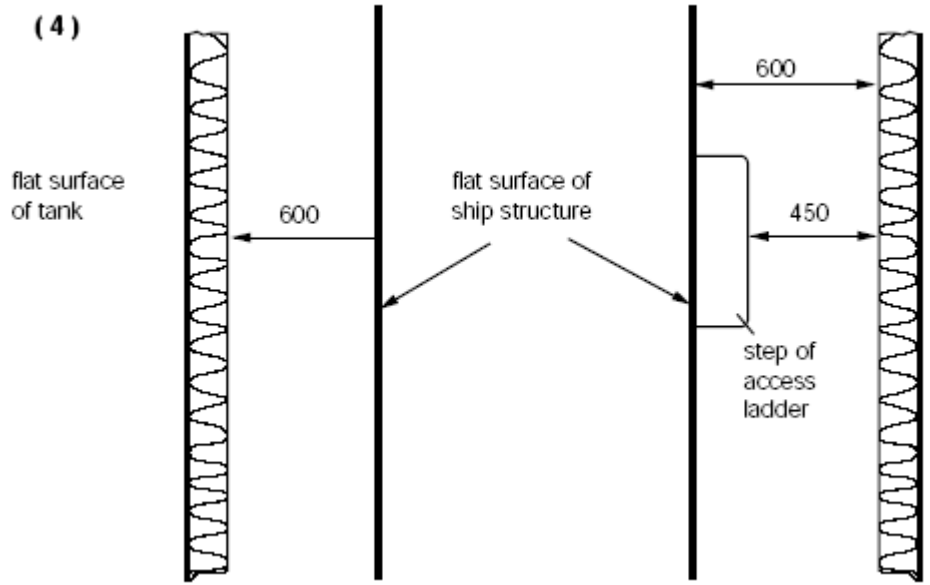

Guidance for sizing pressure relief systems for interbarrier spaces

Interpretation of the second sentence of paragraph 8.1 of the IMO International Code for the Construction and Equipment of Ships Carrying Liquefied Gases in Bulk (MSC.5(48)) as amended by resolutions MSC.17(58), MSC.30(61), MSC.32(63), MSC.59(67), MSC.103(73), MSC.177(79) and MSC.220(82)

The second sentence of paragraph 8.1 reads as follows:

Hold spaces and interbarrier spaces, which may be subject to pressures beyond their design capabilities, shall also be provided with a suitable pressure relief system

Interpretation

1 General

1.1 The formula for determining the relieving capacity given in section 2 is developed for interbarrier spaces surrounding independent type A cargo tanks, where the thermal insulation is fitted to the cargo tanks.

1.2 The relieving capacity of pressure relief devices of interbarrier spaces surrounding independent type B cargo tanks may be determined on the basis of the method given in section 2, however, the leakage rate is to be determined in accordance with 4.7.6.1 of the IGC-Code.

1.3 The relieving capacity of pressure relief devices for interbarrier spaces of membrane and semi- membrane tanks is to be evaluated on the basis of specific membrane/semi-membrane tank design.

1.4 The relieving capacity of pressure relief devices for interbarrier spaces adjacent to integral type cargo tanks may, if applicable, be determined as for type A independent cargo tanks.

1.5 Interbarrier space pressure relief devices in the scope of this interpretation are emergency devices for protecting the hull structure from being unduly overstressed in case of a pressure rise in the interbarrier space due to primary barrier failure. Therefore such devices need not comply with the requirements of 8.2.9 and 8.2.10 of the IGC-Code.

Note:

This interpretation is implemented on ships constructed on or after 1 January 1988 but before 1 July 2016.

2 Size of pressure relief devices

The combined relieving capacity of the pressure relief devices for interbarrier spaces surrounding type A independent cargo tanks where the insulation is fitted to the cargo tanks may be determined by the following formula:

$$Q_{sa} = 3,4 \cdot A_c \frac{\rho}{\rho_v} \sqrt{h} \quad (\text{m}^3/\text{s})$$

Where:

Q_{sa} = minimum required discharge rate of air at standard conditions of 273 K and 1.013 bar

A_c = design crack opening area (m^2)

$$A_c = \frac{\pi}{4} \delta \cdot l \quad (\text{m}^2)$$

δ = max, crack opening width (m)

δ = $0.2t$ (m)

t = thickness of tank bottom plating (m)

l = design crack length (m) equal to the diagonal of the largest plate panel of the tank bottom, see sketch below.

h = max liquid height above tank bottom plus 10.MARVS (m)

ρ = density of product liquid phase (kg/m^3) at the set pressure of the interbarrier space relief device

ρ_v = density of product vapour phase (kg/m^3) at the set pressure of the interbarrier space relief device and a temperature of 273 K

MARVS = max allowable relief valve setting of the cargo tank (bar).

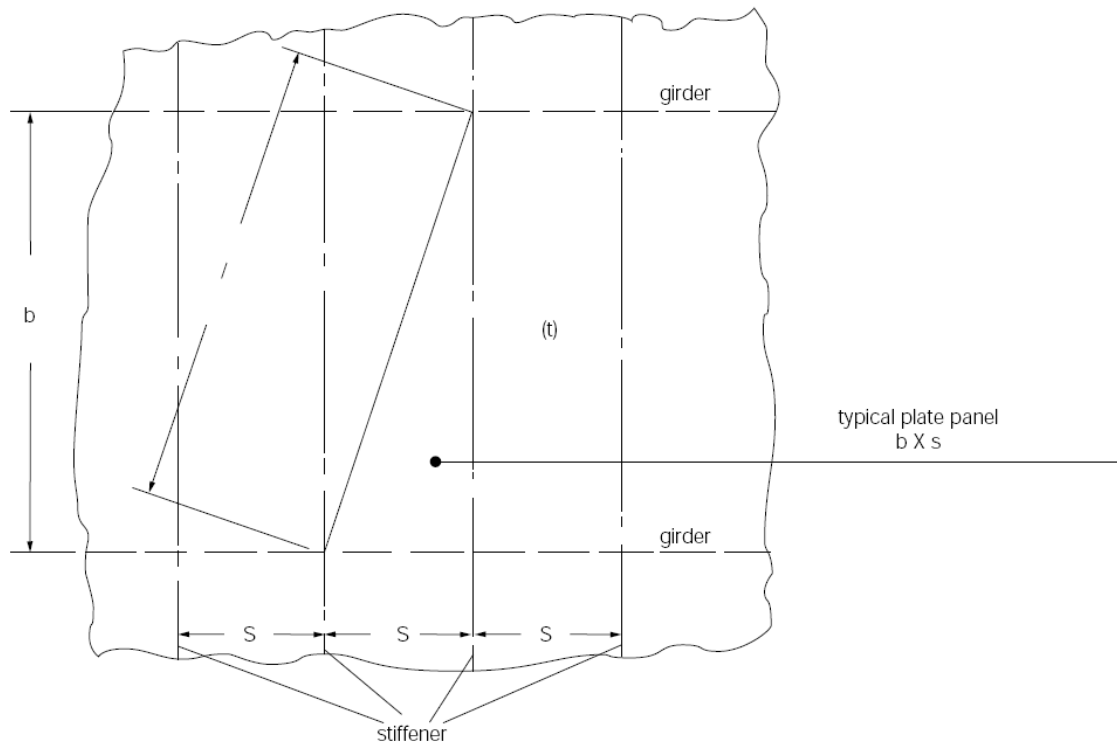

TL- I Reliquefaction plant of motor-driven LNG- GC 10 carriers

Interpretation of the second sentence of paragraph 7.2.1 of the IMO International Code for the Construction and Equipment of Ships Carrying Liquefied Gases in Bulk (MSC.5(48)) as amended by resolutions MSC.17(58), MSC.30(61), MSC.32(63), MSC.59(67), MSC.103(73), MSC.177(79) and MSC.220(82)

The second sentence of paragraph 7.2.1 reads as follows:

Unless an alternative means of controlling the cargo pressure/temperature is provided to the satisfaction of the Administration, a stand-by unit (or units) affording space capacity at least equal to the largest required single unit should be provided

Interpretation

1 Mechanical refrigeration fitted as the primary system for cargo pressure control

1.1 Section 7.2 is based on the assumption that paragraph 7.1.1 is being complied with by using means defined in sub-paragraph 7.1.1.1. That is to say, a mechanical refrigeration system is fitted as the primary means of maintaining the cargo tank pressure below MARVS.

1.2 Section 7.2 should apply to refrigeration systems when fitted on LNG carriers, ie standby capacity will be required as detailed in 7.2.1. A stand-by LNG/refrigerant heat exchanger need not be provided and the fitted LNG/refrigerant heat exchanger will not be required to have 25% excess capacity over that for normal requirements¹. Other heat exchangers utilizing water cooling should have a stand-by or have at least 25% excess capacity.

1.3 Paragraph 7.2.1 states that unless an alternative means of controlling the cargo pressure/temperature is provided to the satisfaction of the Administration, a stand-by unit (or units) affording spare capacity at least equal to the largest required single unit should be fitted.

For the purpose of complying with the above, a suitable alternative means of pressure/temperature control would be:

1.3.1 Auxiliary boiler(s) capable of burning the boil-off vapours and disposing of the generated steam or an alternative waste heat system acceptable to the Society. Consideration will be given to systems burning only part of the boil-off vapour if it can be shown that MARVS will not be reached within a period of 21 days.

¹. The reason for this relaxation is that corrosion and fouling problems are not expected in LNG/refrigerant heat exchangers.

Note:

This interpretation is implemented on ships constructed on or after 1 January 1988 but before 1 July 2016.

1.3.2 Controlled venting of cargo vapours as specified in paragraph 7.1.1.5 if permitted by the Administrations concerned.

2 Mechanical refrigeration fitted as secondary system for cargo pressure control

Where a refrigeration plant is fitted as a means of disposing of excess energy as detailed in the 2nd sentence of paragraph 7.1.1.2, no stand-by unit will be required for the refrigeration plant.

TL- I GC11 Loading of cargo C tanks for ships constructed before 1 July 2016 and subject to IMO International Code for the Construction and Equipment of Ships Carrying Liquefied Gases in Bulk (MSC.5(48))

(Paragraphs 15.1.2 and 15.1.5 of the IMO International Code for the Construction and Equipment of Ships Carrying Liquefied Gases in Bulk (MSC.5(48)) as amended by Res.MSC.32(63))

Paragraph 15.1.2 reads:

“The maximum loading limit (LL) to which a cargo tank may be loaded should be determined by the following formula:

$$LL = FL\rho_R/\rho_L$$

where:

LL = loading limit expressed in percent which means the maximum allowable liquid volume relative to the tank volume to which the tank may be loaded;

FL = filling limits as specified in 15.1.1 or 15.1.3;

ρ_R = relative density of cargo at the reference temperature; and

ρ_L = relative density of cargo at the loading temperature and pressure.”

Note:

1. This Interpretation is applied on or after 1 July 2016.

Paragraph 15.1.5 reads:

“The Administration may allow type C tanks to be loaded according to the following formula provided that the tank vent system has been approved in accordance with 8.2.18:

$$L_L = FL\rho_R/\rho_L$$

where:

LL = loading limit as specified in 15.1.2;

FL = filling limits as specified in 15.1.1 or 15.1.3;

ρ_R = relative density of cargo at the highest temperature which the cargo may reach upon termination of loading, during transport, or at unloading, under the ambient design temperature conditions described in 7.1.2; and

ρ_L = as specified in 15.1.2.

This paragraph does not apply to products requiring a type 1G ship.”

Interpretation

For ships constructed before 1 July 2016 and subject to IMO International Code for the Construction and Equipment of Ships Carrying Liquefied Gases in Bulk (MSC.5(48)), type C cargo tanks can be loaded in accordance with the provisions of paragraph 15.1.5 or, alternatively, to the provisions of paragraph 15.1.2.

TL-I Examination before and after the first loaded GC 13 voyage

Interpretation of paragraphs 4.10.14 and 4.10.16 of the International Code for the Construction and Equipment of Ships Carrying Liquid Gases in Bulk (IGC Code), MSC.5(48) as amended by resolutions MSC.17(58), MSC.30(61), MSC.32(63), MSC.59(67), MSC.103(73), MSC.177(79) and MSC.220(82)

- paragraph 4.10.14 states:

"The overall performance of the cargo containment system should be verified for compliance with the design parameters during the initial cool-down, loading and discharging of the cargo. Records of the performance of the components and equipment essential to verify the design parameters should be maintained and be available to the Administration."

- paragraph 4.10.16 states:

"The hull should be inspected for cold spots following the first loaded voyage."

and,

Interpretation of paragraphs 4.20.3.5 and 4.20.3.7 of the International Code for the Construction and Equipment of Ships Carrying Liquid Gases in Bulk (IGC Code), as amended by Res. MSC.370(93),

- paragraph 4.20.3.5 states:

The overall performance of the cargo containment system shall be verified for compliance with the design parameters during the first full loading and discharging of the cargo, in accordance with the survey procedure and requirements in 1.4 and the requirements of the Administration or recognized organization acting on its behalf. Records of the performance of the components and equipment essential to verify the design parameters, shall be maintained and be available to the Administration.

Note:

1. This Interpretation is to be applied to ships whose keels are laid, or which are at a similar stage of construction, on or after 1 July 2020.

- paragraph 4.20.3.7 states:

The cargo containment system shall be inspected for cold spots during, or immediately following, the first loaded voyage. Inspection of the integrity of thermal insulation surfaces that cannot be visually checked shall be carried out in accordance with recognized standards.

The above paragraphs shall be interpreted as follows:

Application

This Interpretation applies to all vessels carrying liquefied natural gases (LNG) in bulk which have satisfactorily completed gas trials.

Certification

The following initial certificates shall be “conditionally” issued at delivery subject to satisfactory completion of the first cargo loading and unloading survey requirements below in the presence of a Surveyor:

1. Classification Certificate
2. Short Term Certificate of Fitness for the Carriage of Liquefied Gases in Bulk

Note: The conditions may either be stated on the Classification Certificate or issued as a condition of class in the vessel’s Record.

Survey Requirements

• First Loading (considered to be full loading):

1. Priority to be given to latter stages of loading (approximately last 6 hours).
2. Review cargo logs and alarm reports.
3. Witness satisfactory operation of the following:
 - Gas detection system.
 - Cargo control and monitoring systems such as level gauging equipment, temperature sensors, pressure gauges, cargo pumps and compressors, proper control of cargo heat exchangers, if operating, etc.
 - Nitrogen generating plant or inert gas generator, if operating.
 - Nitrogen pressure control system for insulation, interbarrier, and annular spaces, as applicable.
 - Cofferdam heating system, if in operation.
 - Reliquefaction plant, if fitted.
 - Equipment fitted for the burning of cargo vapors such as boilers, engines, gas combustion units, etc., if operating.
4. Examination of on-deck cargo piping systems including expansion and supporting arrangements.
5. Witness topping off process for cargo tanks including high level alarms activated during normal loading.

-
6. Advise master to carry out cold spot examination of the hull and external insulation during transit voyage to unloading port.

- **First Unloading:**

1. Priority to be given to the commencement of unloading (approximately first 4 - 6 hours).
2. Witness emergency shutdown system testing prior to commencement of unloading.
3. Review cargo logs and alarm reports.
4. Witness satisfactory operation of the following:
 - Gas detection system.
 - Cargo control and monitoring systems such as level gauging equipment, temperature sensors, pressure gauges, cargo pumps and compressors, proper control of cargo heat exchangers, if operating, etc.
 - Nitrogen generating plant or inert gas generator, if operating.
 - Nitrogen pressure control system for insulation, interbarrier, and annular spaces, as applicable.
 - On membrane vessels, verify that the readings of the cofferdam and inner hull temperature sensors are not below the allowable temperature for the selected grade of steel. Review previous readings.
 - Cofferdam heating system, if in operation.
 - Reliquefaction plant and review of records from previous voyage.
 - Equipment fitted for the burning of cargo vapors such as boilers, engines, gas combustion units, etc., if operating.
5. Examination of on-deck cargo piping systems including expansion and supporting arrangements.
6. Obtain written statement from the Master that the cold spot examination was carried out during the transit voyage and found satisfactory. Where possible, the surveyor should examine selected spaces.

TL- I GC15 Closing Devices for Air Intakes

Interpretation of paragraph 3.2.6 of the IMO International Code for the Construction and Equipment of Ships Carrying Liquefied Gases in Bulk (Resolution MSC.5(48) as amended by Resolution MSC.370(93))

Paragraph 3.2.6 reads:

All air intakes, outlets and other openings into the accommodation spaces, service spaces and control stations shall be fitted with closing devices. When carrying toxic products, they shall be capable of being operated from inside the space. The requirement for fitting air intakes and openings with closing devices operated from inside the space for toxic products need not apply to spaces not normally manned, such as deck stores, forecastle stores, workshops. In addition, the requirement does not apply to cargo control rooms located within the cargo area.

Interpretation

1. The closing devices that need not be operable from within the single spaces may be located in centralized positions.
2. Engine room casings, cargo machinery spaces, electric motor rooms and steering gear compartments are generally considered as spaces not covered by paragraph 3.2.6 and, therefore, the requirement for closing devices need not be applied to these spaces.
3. The closing devices should give a reasonable degree of gas tightness. Ordinary steel fire-flaps without gaskets/seals should not be considered satisfactory.
4. Regardless of this interpretation, the closing devices shall be operable from outside of the protected space (SOLAS regulation II-2/5.2.1.1).

Note:

1. This interpretation is implemented on ships constructed on or after 1 January 2018.

TL- I GC16 Cargo tank clearances (on ships constructed on or after 1 July 2016)

The International Code for the Construction and Equipment of Ships Carrying Liquid Gases in Bulk (IGC Code) as amended by Res. MSC.370(93), 3.5.3.1.2 reads:

“access through horizontal openings, hatches or manholes. The dimensions shall be sufficient to allow a person wearing a breathing apparatus to ascend or descend any ladder without obstruction and also to provide a clear opening to facilitate the hoisting of an injured person from the bottom of the space. The minimum clear opening shall be not less than 600 mm x 600 mm;”

Interpretation

The minimum clear opening of 600 mm x 600 mm may have corner radii up to 100 mm maximum. In such a case where as a consequence of structural analysis of a given design the stress is to be reduced around the opening, it is considered appropriate to take measures to reduce the stress such as making the opening larger with increased radii, e.g. 600 x 800 with 300 mm radii, in which a clear opening of 600 mm x 600 mm with corner radii up to 100 mm maximum fits.

Technical Background

The interpretation is based upon the established Guidelines in MSC/Circ.686.

Ref.

Paragraphs 9 of Annex of MSC/Circ.686.

Note:

1. This interpretation is implemented on ships whose keels are laid, or which are at a similar stage of construction, on or after 1 July 2016.
2. For ships with keels laid, or at a similar stage of construction, before 1 July 2016, refer to TL- I GC6.

The International Code for the Construction and Equipment of Ships Carrying Liquid Gases in Bulk (IGC Code) as amended by Res. MSC.370(93), 3.5.3.1.3 reads:

“access through vertical openings or manholes providing passage through the length and breadth of the space. The minimum clear opening shall be not less than 600 mm x 800 mm at a height of not more than 600 mm from the bottom plating unless gratings or other footholds are provided;”

Interpretation

1. The minimum clear opening of not less than 600 mm x 800 mm may also include an opening with corner radii of 300 mm. An opening of 600 mm in height x 800 mm in width may be accepted as access openings in vertical structures where it is not desirable to make large opening in the structural strength aspects, i.e. girders and floors in double bottom tanks.

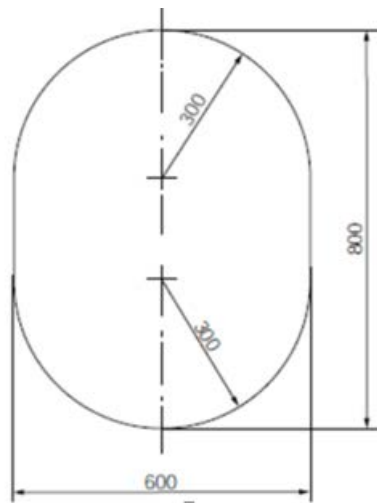

2. Subject to verification of easy evacuation of injured person on a stretcher the vertical opening 850 mm x 620 mm with wider upper half than 600 mm, while the lower half may be less than 600 mm with the overall height not less than 850 mm is considered an acceptable alternative to the traditional opening of 600 mm x 800 mm with corner radii of 300 mm.

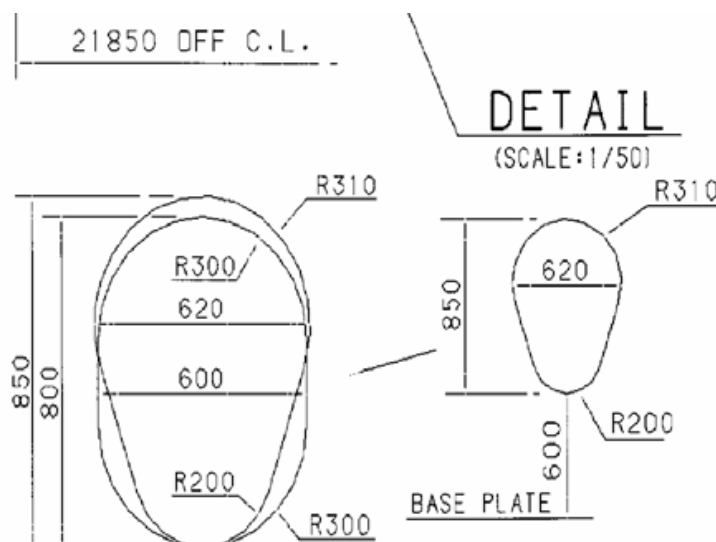

3. If a vertical opening is at a height of more than 600 mm steps and handgrips are to be provided. In such arrangements it is to be demonstrated that an injured person can be easily evacuated.

Technical Background

The interpretation is based upon the established Guidelines in MSC/Circ.686 and an innovative design is considered for easy access by humans through the opening.

Ref.

Paragraphs 11 of Annex of MSC/Circ.686.